

GRAELL LTD

# SIERRA RUTILE PROJECT AREA 1

## ENVIRONMENTAL, SOCIAL AND HEALTH IMPACT ASSESSMENT: HYDROGEOLOGICAL STUDY

---

**JANUARY 2018**

Report No: 515234/Hydrogeology



A handwritten signature in black ink, appearing to read 'Rainer Krantz'.

Rainer Krantz

*Graell Ltd*

*11 Ter Dauphine Street*

*Port Louis*

*Mauritius*

*Tel :+230 54986789*

*Email: [rainer@graelltd.com](mailto:rainer@graelltd.com)*

## Executive Summary

Sierra Rutile Limited (SRL) is an existing mining operation located in the Bonthe and Moyamba Districts of the Southern Province of Sierra Leone. In 2015 the Environmental Protection Agency of Sierra Leone (EPA-SL) issued a notification to SRL (reference number EPA-SUHA.96/214/a/HNRM), instructing them to undertake an integrated Environmental, Social and Health Impact Assessment (ESHIA) and develop an Environmental, Social and Health Management Plan (ESHMP) for their current and proposed dry and wet mining activities, including the proposed expansion areas. SRK Consulting (South Africa) (Pty) Ltd (SRK) was appointed by SRL to undertake the ESHIA. Graell Ltd (Graell) was appointed by SRK to undertake the hydrogeological specialist study as part of this assessment.

The hydrogeological investigation was conducted in phases commencing with an initial site visit to assess on-site conditions. A total of 19 additional boreholes were drilled throughout SRL's Mine Lease Area 1 (SR Area 1), with some emphasis on the dry mining areas to support future dewatering efforts. The monitoring boreholes were subjected to a constant rate test followed by recovery. Groundwater sampling and groundwater modelling will be undertaken throughout 2018 and the results will be included as an addendum to the ESHIA. A preliminary impact assessment has also been undertaken.

Tertiary to Recent sediments overlie the gneissic basement of the Kasila Group which covers the majority of SR Area 1. Bullom sediments are located on the western boundary of the study area within a coastal strip.

The relatively impermeable fresh basement forms the effective base of the hydrogeological regime. Given the close proximity to source, the unconsolidated Tertiary and Recent sediments have similar hydrogeological characteristics to the weathered basement and as such have been grouped together as a hydrostratigraphic unit. The underlying weathered/fresh basement contact yields a relatively consistent if variable water strike and has been identified as a second hydrostratigraphic unit.

Groundwater gradients currently mimic the topography suggesting a limited influence of mining to date. Rainfall recharge has been simulated by SRK to be in the order of 0.17% - 2.6% Mean Annual Precipitation (MAP) for the various catchments across SR Area 1.

The poorly sorted unconsolidated sediments and weathered bedrock tend to have a low transmissivity ( $0.12 \text{ m}^2/\text{day} - 6 \text{ m}^2/\text{day}$ ) whereas the weathered/fractured basement contact has a wider transmissivity range ( $6 \text{ m}^2/\text{day} - 200 \text{ m}^2/\text{day}$ ) depending on the nature of the contact at a specific location. The Bullom sediments have the highest transmissivity, which is estimated to be in the order of  $300 \text{ m}^2/\text{day}$ .

The primary mining method has historically been dredge mining. During 2013, SRL commenced a distinct open cast mining operation (dry mining) as an auxiliary method of ore extraction. In 2016 a second dry mining operation was commissioned. It is anticipated that, over time, dredge mining will cease, and dry mining would be the primary mining method employed.

Lanti and the historical mining ponds were created by damming the river valleys behind engineered earthen walls to facilitate dredge mining within the alluvial sediments. Mining no longer takes place within the historical mining ponds which are now used by the local population as a domestic water source. The impact of the mining ponds on the groundwater levels and baseflow is limited to the immediately adjacent river valleys.

Given the low permeability of the ore deposit, the groundwater ingress volumes into the dry mining operations should be manageable and dewatering may be achieved through the use of trenches which are connected to sumps at the lowest elevation. Substantially higher groundwater ingress volumes are anticipated should the dry mining operations encounter Bullom sediments such as at Foinda village at Gbeni and in the northern extent of the Gangama deposit. Alternative mining methods may have to be considered under these circumstances.

Ore is located within the vicinity of the pineapple farm immediately adjacent to the Lanti dredge pond. Monitoring borehole SRL17/14 in this area has a blow yield of 32 l/sec which suggests very high permeabilities associated with the underlying Bullom sediments. It is planned that this area will be dredged to avoid substantial water ingress during dry mining.

Upon mine closure, the groundwater gradients are expected to recover to their ambient levels especially if the post mining topography reflects the pre-mining conditions and diverted rivers are reinstated. The planned lowering of the mining pond levels during the rehabilitation phase, will also assist in this regard.

The ambient groundwater quality is slightly to moderately acidic (pH 4.38) with low Total Dissolved Solids (TDS) (5.56 mg/l to 77.9 mg/l) as expected in heavily leached environments in humid tropical climates. Community boreholes indicate extensive bacteriological contamination which is attributed to human impacts.

With the exception of pH and aluminium, historical sampling has shown that the water quality within SR Area 1 generally falls within the World Health Organisation (WHO) drinking water standards and the Republic of Sierra Leone effluent standards. Although the active Lanti mining pond has a lower pH and higher TDS than the historical mining ponds, the water quality is expected to improve post mining.

The primary processed tailings material is inert. However, SRK has determined that elevated concentrations of aluminium, copper, iron, potassium, manganese, sulfate and zinc in the leachate from this material relative to background surface water, are expected.

Changes to groundwater quality due to the SRL operations are greatest around the secondary processed tailings disposal area at the mineral separation plant.

Knight Piesold determined that the supernatant discharge from the coarse sulphide plant tailings outlet pipe into the sulphide plant tailings holding area had radioactivity levels that exceeded the World Health Organization (WHO) guidelines (2008) for gross alpha and gross beta. Process/surface water locations downstream of the Mogbwemo dredge pond however did not exceed WHO guidelines, indicating a minimal impact from these discharge sources. Further radioactivity assessments are currently being undertaken by SRL in this regard.

Saline intrusion will be a factor if dry mining is undertaken in close proximity to the estuary in the northern extremity of the Gangama deposit. Rehabilitation and mining alternatives will need to be considered especially if the area is underlain by Bullom sediments.

The impact assessment has shown that the majority of the mining impacts on groundwater are localized and range from the short to long term. The greatest risk associated with groundwater is the contribution to dam wall failure and a major hydrocarbon spill at Nitti Port from the storage tanks. Impacts from the SRL mining operations may be improved with the implementation of the recommended mitigation and monitoring measures.

## TABLE OF CONTENTS

1	Introduction.....	1
2	Legislative Requirements .....	3
3	Current Scope of Work.....	3
4	Hydrogeological Investigation Methodology .....	4
4.1	Data .....	4
4.2	Site Visit.....	4
4.3	Additional Field Work.....	5
4.4	Groundwater Conceptual Modelling.....	6
4.5	Numerical Modelling.....	6
4.6	Impact Assessment .....	6
4.7	Reporting.....	6
5	Previous Investigations .....	7
5.1	Water Monitoring Report (Knight Piesold, 2008) .....	7
5.2	Site Visit Memo (SRK, 2013) .....	8
5.3	Water Quality Monitoring Protocol for Sierra Rutile Mine (SRK, 2013).....	9
6	Site Description.....	11
6.1	SR Area 1 Mining Operations.....	11
6.2	Rainfall.....	12
6.3	Regional Topography and Drainage .....	12
6.4	Tidal Fluctuations .....	14
7	Geological Setting .....	15
7.1	Regional Geology .....	15
7.2	SR Area 1 Geology.....	16
8	Hydrogeology.....	20
8.1	Monitoring Borehole Drilling.....	20

## TABLE OF CONTENTS (CONT)

8.2	Hydrostratigraphy .....	22
8.3	Observed Groundwater Levels .....	23
8.4	Aquifer Parameters .....	25
8.5	Groundwater Users .....	29
8.6	Hydrochemistry.....	31
8.6.1	Potential Contamination Sources .....	31
8.6.2	Borehole Hydrochemistry.....	32
8.6.3	Detailed Historical Water Analyses .....	36
9	SR Area 1 Mining Influence on Groundwater .....	39
9.1	Historical Mining Ponds.....	39
9.2	MSP and Tailings Facilities.....	40
9.3	Lanti Wet Mining.....	40
9.4	Gbeni Dry Mining .....	41
9.5	Gangama Dry Mining.....	43
9.6	Nitti Port .....	44
9.7	Waste Disposal Facility.....	45
10	Groundwater Conceptual Model .....	46
11	Impact Assessment .....	51
11.1	Impact Assessment Methodology.....	51
11.2	Direct Impacts.....	53
11.2.1	Impact 1a – Elevated Historical Mining Pond Levels May Increase the Available Drawdown in Community Boreholes (Operational Phase) .....	54
11.2.2	Impact 1b – Lowered Historical Mining Pond Levels May Reduce the Available Drawdown in Community Boreholes (Decommissioning Phase).....	55
11.2.3	Impact 1c – Lowered Historical Mining Pond Levels May Expose Sulphides Leading to Groundwater Acidification (Decommissioning Phase).....	56

## TABLE OF CONTENTS (CONT)

11.2.4	Impact 2a – Seepage from MSP Tailings and Dams Raising Groundwater Levels (Operational Phase).....	58
11.2.5	Impact 2b – Decommissioning the MSP Tailings and Dams Will Lower Groundwater Levels Beneath the Tailings Disposal Area (Decommissioning Phase).....	59
11.2.6	Impact 2c – MSP Hydrocarbon and Sewage Spills Contaminating Groundwater (Operational Phase).....	60
11.2.7	Impact 2d – MSP Secondary Processed Tails Acid Generation Contaminating Groundwater (Operational and Decommissioning Phase).....	62
11.2.8	Impact 3a – Elevated Lanti Mining Pond Levels May Increase the Available Drawdown in Community Boreholes (Operational Phase) .....	63
11.2.9	Impact 3b – Lowered Lanti Mining Pond Levels May Reduce the Available Drawdown in Community Boreholes (Decommissioning Phase) .....	65
11.2.10	Impact 3c – Lanti Dredge Hydrocarbon and Sewage Spills Contaminating Groundwater (Operational Phase).....	66
11.2.11	Impact 3d – Lanti Mining Pond Water May Lead to Groundwater Contamination (Operational Phase).....	68
11.2.12	Impact 3e – Lowered Lanti Mining Pond Level May Expose Sulphides Leading to Groundwater Acidification (Decommissioning Phase).....	69
11.2.13	Impact 4a – Gbeni and Gangama Dry Mining Dewatering Leading to Lowered Groundwater Levels (Operational Phase) .....	71
11.2.14	Impact 4b – Gbeni and Gangama Dry Mining Groundwater Gradients Recover Post-Mining (Decommissioning Phase).....	72
11.2.15	Impact 4c – Gangama Dry Mining Groundwater Ingress Adjacent to the Estuary (Operational Phase).....	74
11.2.16	Impact 4d – Gbeni and Gangama Dry Mining Hydrocarbons Contaminating Groundwater (Operational Phase).....	75
11.2.17	Impact 4e – Gbeni and Gangama Dry Mining Sulphide Exposure Contaminating Groundwater (Operational and Decommissioning Phase).....	77
11.2.18	Impact 4f – Gangama Dry Mining Saline Intrusion Contaminating Groundwater (Operational and Decommissioning Phase).....	78
11.2.19	Impact 5a – Nitti Port Hydrocarbon Spillage Contaminating Groundwater (Operational Phase).....	80

## TABLE OF CONTENTS (CONT)

11.2.20	Impact 6a – Waste Disposal Site Leachate Contaminating Groundwater (Operational and Decommissioning Phase).....	82
11.3	Indirect Impacts .....	83
11.3.1	Impact 7a – Raised Historical Mining Pond Levels Altering Groundwater Baseflow Distribution to Surface Water Systems (Operational Phase) .....	83
11.3.2	Impact 7b – Lowered Historical Mining Pond Levels Altering Groundwater Baseflow Distribution to Surface Water Systems (Decommissioning Phase).....	84
11.3.3	Impact 8a – Lanti Mining Pond Retarding Groundwater Baseflow to Surface Water Systems (Operational and Decommissioning Phase).....	86
11.3.4	Impact 8b – Seepage of Poor Quality Groundwater Through The Lanti Mining Pond Wall and Weathered Aquifer Discharging Into The Surface Water Systems (Operational Phase).....	87
11.3.5	Impact 9a – Failure of the Historical and Lanti Mining Pond Walls As a Result of Groundwater Seepage (Operational and Decommissioning Phase).....	88
11.3.6	Impact 10a – Gbeni and Gangama Dry Mining Slope Failure As a Result of Groundwater Seepage (Operational Phase).....	90
11.3.7	Impact 10b – Gbeni and Gangama Dry Mining Saturation Due to Groundwater Ingress (Operational Phase).....	91
11.3.8	Impact 10c – Suspended Solids from the Gbeni and Gangama Dry Mining Dewatering Volumes Contaminating Surface Water (Operational Phase) .....	93
11.4	Cumulative Impacts.....	94
12	Assumptions and Limitations .....	95
12.1	Assumptions .....	95
12.2	Limitations .....	95
13	Mitigation Measures.....	96
14	Post Mining Conditions .....	98
15	Monitoring Requirements .....	99
15.1	Groundwater Monitoring Network.....	99
15.2	Monitoring Frequency and Parameters .....	99



**TABLE OF CONTENTS (CONT)**

15.3 Additional Monitoring Requirements ..... 100

16 Conclusions..... 102

17 Recommendations ..... 105

18 Acknowledgements..... 106

19 References..... 107

APPENDIX A: borehole logs.....A

APPENDIX B: pump testing analyses ..... B

APPENDIX C: historical water analyses and effluent standards..... C

## LIST OF TABLES

Table 7-1: SRL Lithological Codes .....	17
Table 8-1: SR Area 1 Monitoring Borehole Drilling .....	22
Table 8-2: SR Area 1 Pump Testing Results.....	27
Table 8-3: SR Area 1 Village/Community Boreholes .....	29
Table 11-1: Impact Assessment Significance Rating.....	52
Table 11-2: Impact 1a – Impact Assessment Summary.....	54
Table 11-3: Impact 1b - Impact Assessment Summary .....	56
Table 11-4: Impact 1c - Impact Assessment Summary.....	57
Table 11-5: Impact 2a - Impact Assessment Summary.....	59
Table 11-6: Impact 2b - Impact Assessment Summary .....	60
Table 11-7: Impact 2c - Impact Assessment Summary.....	61
Table 11-8: Impact 2d - Impact Assessment Summary .....	63
Table 11-9: Impact 3a - Impact Assessment Summary.....	64
Table 11-10: Impact 3b - Impact Assessment Summary .....	66
Table 11-11: Impact 3c - Impact Assessment Summary.....	67
Table 11-12: Impact 3d - Impact Assessment Summary .....	69
Table 11-13: Impact 3e - Impact Assessment Summary.....	70
Table 11-14: Impact 4a - Impact Assessment Summary.....	72
Table 11-15: Impact 4b - Impact Assessment Summary .....	73
Table 11-16: Impact 4c - Impact Assessment Summary.....	75
Table 11-17: Impact 4d - Impact Assessment Summary .....	76
Table 11-18: Impact 4e - Impact Assessment Summary.....	78
Table 11-19: Impact 4f - Impact Assessment Summary .....	80
Table 11-20: Impact 5a - Impact Assessment Summary.....	81
Table 11-21: Impact 6a - Impact Assessment Summary.....	82
Table 11-22: Impact 7a - Impact Assessment Summary.....	84
Table 11-23: Impact 7b - Impact Assessment Summary .....	85
Table 11-24: Impact 8a - Impact Assessment Summary.....	87
Table 11-25: Impact 8b - Impact Assessment Summary .....	88
Table 11-26: Impact 9a – Impact Assessment Summary.....	89
Table 11-27: Impact 10a - Impact Assessment Summary.....	91
Table 11-28: Impact 10b: Impact Assessment Summary .....	92
Table 11-29: Impact 10c - Impact Assessment Summary.....	94

## LIST OF FIGURES

Figure 1-1: SR Area 1 Locality Map.....	2
Figure 6-1: MSP Average Monthly Precipitation (after Golder, 2017) .....	12
Figure 6-2: SR Area 1 - Topography and Drainage .....	13
Figure 7-1: Sierra Leone Regional Geology .....	15
Figure 7-2: SR Area 1 Geological Map .....	16
Figure 7-3: SRL Geological Block Model Slimes % vs Lithology .....	18
Figure 7-4: Gangama and Gbeni Deposits Block Model Centres >60% Slimes .....	19
Figure 8-1: SR Area 1 Monitoring Borehole Drilling Locations.....	21
Figure 8-2: SR Area 1 Depth To Groundwater (mbc).....	24
Figure 8-3: SR Area 1 Topography vs Groundwater Level (mamsl).....	25
Figure 8-4: SR Area 1 Blow Yields (l/sec) .....	26
Figure 8-5: SR Area 1 Transmissivity Distribution (m <sup>2</sup> /day).....	28
Figure 8-6: SR Area 1 Village/Community Boreholes .....	30
Figure 8-7: Groundwater pH Response to Rainfall.....	33
Figure 8-8: Groundwater TDS Response to Rainfall .....	34
Figure 8-9: Groundwater TDS Response vs pH .....	35
Figure 8-10: SR Area 1 Piper Diagram.....	37
Figure 10-1: Ambient Hydrogeological Conditions .....	46
Figure 10-2: Historical Mining Pond Groundwater Flow Patterns .....	47
Figure 10-3: Lanti Mining Pond Groundwater Flow Patterns .....	48
Figure 10-4: Gbeni Pre Mining Groundwater Flow Patterns .....	48
Figure 10-5: Gbeni Groundwater Flow Patterns During Mining .....	49

## LIST OF PHOTOS

Photo 9-1: Gbeni Dry Mine Box Cut .....	42
---	----

## LIST OF ABBREVIATIONS

CET	Coarse Electrostatic Tailings
EC	Electrical Conductivity
EPA-SL	Environmental Protection Agency of Sierra Leone
ESHIA	Environmental, Social and Health Impact Assessment
ESHMP	Environmental, Social and Health Management Plan
FET	Fine Electrostatic Tailings
GIIP	Good International Industry Practice
Graell	Graell Ltd
HMC	Heavy Mineral Concentrate
HP	Horse Power
IT	Ilmenite Tailings
LOM	Life of Mine
mbc	Metres below collar
MFO	Marine Fuel Oil
MAP	Mean Annual Precipitation
mamsl	metres above mean sea level
MSP	Mineral Separation Plant
NEPAD	New Economic Program for African Development
NGO	Non-governmental Organisations
SFT	Sulfide Tailings Stream
SR Area 1	SRL's Mine Lease Area 1
SRK	SRK Consulting (South Africa) (Pty) Limited
TDS	Total Dissolved Solids
TT	Total Tailings
WHO	World Health Organization

## 1 INTRODUCTION

Sierra Rutile Limited (SRL) is an existing mining operation located in the Bonthe and Moyamba Districts of the Southern Province of Sierra Leone (**Figure 1-1**). The mine has been in operation for over 50 years and produces rutile, ilmenite and zircon rich concentrate. The SRL operation has an existing Environmental Licence (reference number EPA-SL030) and has undertaken two previous Environmental and Social Impact Assessment (ESIA) studies for their operations in 2001 and an update in 2012 respectively. When these studies were undertaken, the primary mining process was dredge mining (referred to as wet mining). During 2013 SRL commenced a distinct open cast mining operation (referred to as dry mining) as an auxiliary method of ore extraction in conjunction with wet mining. In 2016 a second dry mining operation was commissioned. It is anticipated that, over time, dredge mining will cease, and dry mining would be the primary mining method employed.

In 2015 the Environmental Protection Agency of Sierra Leone (EPA-SL) issued a notification to SRL (reference number EPA-SUHA.96/214/a/HNRM), instructing them to undertake an integrated Environmental, Social and Health Impact Assessment (ESHIA) and develop an Environmental, Social and Health Management Plan (ESHMP) for their current and proposed dry and wet mining activities, including the proposed expansion areas. This includes the Gangama, Gbeni and Lanti deposits and other deposits within SRL's current operating concession in SRL Mining Lease Area 1 (SR Area 1 / the study area).

SRK Consulting (South Africa) (Pty) Ltd (SRK) was appointed by SRL to undertake the ESHIA. Graell Ltd (Graell) was appointed by SRK to undertake the hydrogeological specialist study as part of this assessment.

This document details the methodology, results and conclusions of the hydrogeological investigation and describes the recommendations for further work.

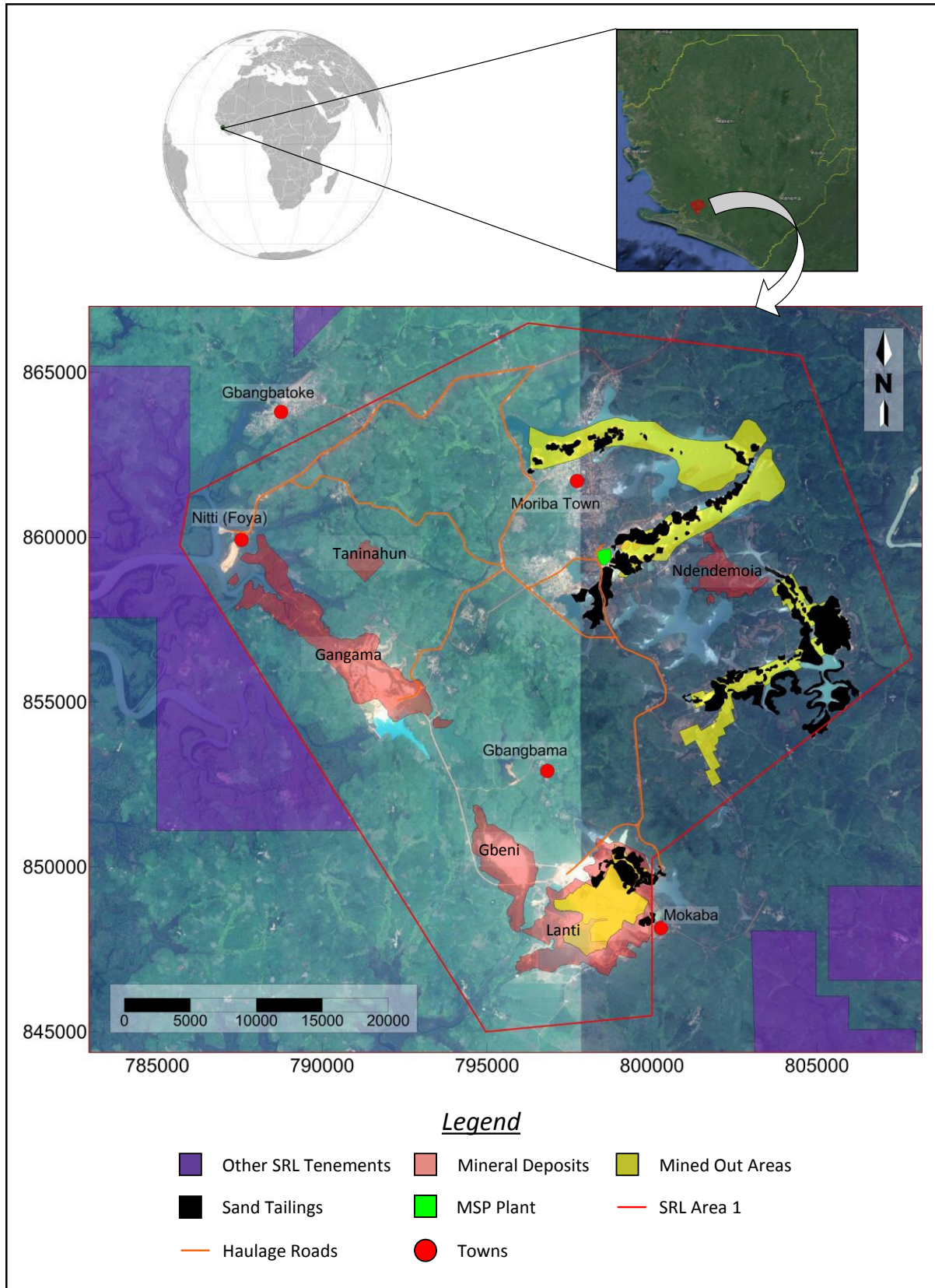


Figure 1-1: SR Area 1 Locality Map

## 2 LEGISLATIVE REQUIREMENTS

The following Sierra Leone legislation is considered most relevant to this specialist study:

- *SR Agreement (Ratification) Act, 2002;*
- *The Environment Protection Agency Act, 2008;*
- *The Mine and Minerals Act, 2009,* and
- *The Environment Protection (Mines and Minerals) Regulations, 2013.*

This legislation was taken into consideration during the hydrogeological investigation and compilation of this specialist report.

## 3 CURRENT SCOPE OF WORK

The current scope of work for this hydrogeological assessment is set out in the following phases:

- Phase 1 – Initial site visit to verify the key issues regarding the groundwater regime;
- Phase 2 – Field investigations to augment the current groundwater monitoring data;
- Phase 3 – Groundwater modelling to simulate the current and future impacts of the SRL operations and to assist in the selection of the appropriate management measures;
- Phase 4 – Impact assessment, and
- Phase 5 – Reporting the groundwater investigation including results, impact assessment, conclusions and recommendations.

Phases 1 and 2 have been completed with the exception of the groundwater sampling. Due to delays in the monitoring borehole drilling program, the Phase 3 groundwater modelling will commence during 2018 and will be added as an addendum to the ESHIA once completed.

A preliminary impact assessment has been completed as part of this report.

## 4 HYDROGEOLOGICAL INVESTIGATION METHODOLOGY

The following methodology was undertaken during the course of this investigation.

### 4.1 Data

SRL provided the following data as input into this investigation:

- Topographic and other GIS information as shapefiles;
- Regional and detailed geological maps for SR Area 1;
- Geological assessments undertaken by SRL personnel;
- Detailed geological information for the Gbeni and Gangama dry mining areas in the form of block model centroids;
- The location of community wells that are currently being monitored;
- Historical groundwater, rainfall and hydrochemistry monitoring data in Excel, and
- Historical water assessment reports.

This data was processed in Excel, Surfer and Global Mapper for the evaluation of the hydrogeological regime within the study area.

### 4.2 Site Visit

A site visit was undertaken during July 2017 to SR Area 1 to view the on-site conditions. This included a visit to the various operations including:

- The historical mining ponds;
- Lanti wet mining;
- Lanti dry mining (DM1) (Gbeni), and Gangama dry mining (DM2);
- Mineral Separation Plant (MSP);
- Landfill site, and
- Nitti Port.

The nearby rivers were also inspected as potential boundary conditions for the subsequent groundwater modelling exercise. Meetings were also held with the SRL personnel to ensure that the objectives of the investigation were aligned with the current and future mining operations.



The proposed drilling locations for additional monitoring boreholes were identified based on the existing on-site conditions and marked in the field. It was decided that a geophysical survey was not required for the detailed siting of the boreholes since the focus was on the unconsolidated sediments and weathered/fresh basement contact. The underlying fresh basement was not investigated since this is largely impermeable with groundwater flow restricted to isolated fractures.

### **4.3 Additional Field Work**

The historical groundwater monitoring network consisted of 5 piezometers installed around the MSP, 3 piezometers at the landfill site, 2 piezometers at Nitti Port and 12 community wells. A number of these piezometers have been vandalized and are no longer functional. An additional 19 monitoring boreholes were drilled as part of this investigation to determine the ambient groundwater conditions away from the mining operations and the impact of the historical mining ponds on the groundwater regime. Specific focus is also given to the dry mining operations to gather hydrogeological data to support future dewatering efforts as the mining extends beneath the groundwater surface.

Boreholes monitoring ambient groundwater conditions are located on the northern and south eastern boundary of SR Area 1 distant from any historical, current or planned mining operations. The boreholes monitoring the historical mining ponds are located on the watersheds immediately adjacent to these features so that any groundwater fluctuations in response to the mining pond levels may be determined. Borehole pairs have also been drilled in the Gangama and Gbeni dry mining deposits to monitor the groundwater response within the orebody and the underlying weathered/fractured basement contact to dewatering.

The boreholes were pump tested at a constant rate by means of a 2 Horse Power (HP) and 5HP submersible Pedrollo pump. The testing duration ranged between 2 hours and 3 hours depending on the groundwater level response in each case. Recovery data following the constant rate pump test was also obtained. The results were evaluated on a daily basis and pump tests were replicated to improve the dataset where required. Boreholes SRL17/8A and SRL17/9A were slug tested since their yields were too low for pump testing purposes.

Groundwater sampling has not been undertaken to date due to the delay in the monitoring borehole drilling program. This activity will be undertaken during the course of 2018.

#### **4.4 Groundwater Conceptual Modelling**

Groundwater conceptual modelling is a process whereby the field observations are documented in terms of geohydrological and hydrostratigraphic characteristics, which may be translated into numerical terms during the modelling process. Previous experience and knowledge of the host lithologies are also reflected in the groundwater conceptual model especially where there is limited available field data or time dependent observations.

The data provided by SRL has been used to characterize the hydrogeological setting and to delineate the aquifers with the study area. The likely behaviour of the groundwater regime in response to mining has also been determined. This is described in terms of a groundwater conceptual model.

#### **4.5 Numerical Modelling**

Numerical groundwater modelling to simulate the mining operations within SR Area 1 will be undertaken during the course of 2018. The results of this exercise will be submitted to the EPA-SL as an addendum to the ESHIA once completed.

#### **4.6 Impact Assessment**

A preliminary impact assessment has been undertaken from a hydrogeological perspective. The methodology prescribed by SRK has been used as part of this exercise. The results of this assessment have been included in this report.

#### **4.7 Reporting**

The results of the hydrogeological investigation to date have been included in this document. The detail in this report is based on legislative requirements in Sierra Leone as well as Good International Industry Practice (GIIP). Recommendations for future monitoring and mitigation measures have also been included.

## 5 PREVIOUS INVESTIGATIONS

Three historical reports have been provided by SRL/SRK as part of this investigation namely:

- Water Monitoring Report by Knight Piesold (2008);
- Site Visit Memo by SRK (2013), and
- Water Quality Monitoring Protocol for Sierra Rutile Mine by SRK (2013).

These reports are described in more detail below.

### 5.1 Water Monitoring Report (Knight Piesold, 2008)

The main highlights of this report are as follows.

The bedrock is a Precambrian, high-grade quartzo-feldspathic-garnet gneiss (charnockite) with accessory rutile, ilmenite, zircon, and monazite. Weathering of the bedrock with the subsequent concentration of heavy minerals in detrital placer deposits formed the mineral sands deposits in SR Area 1.

Tertiary aged alluvial deposits overlie the laterites although some of the alluvial sands are also well cemented or laterized.

During sea level fluctuations organic sediments in low lying areas contributed to anaerobic reducing conditions which allowed soluble iron to combine with sulphate from seawater, to form authigenic pyrite and marcasite. These minerals represent the greatest possible contamination source associated with mining in SR Area 1.

A shallow alluvial/valley fill aquifer with a thickness of some 15 m and an underlying deeper weathered/fractured basement aquifer with a thickness of 7 m – 15 m were identified. Recharge occurs through rainfall infiltration through the soils. Constant rate pumping tests indicate permeabilities for the shallow aquifer in the range of 10 m/day – 11 m/day.

Water quality in the area is of a moderately low pH (4.0 – 5.6) with low Total Dissolved Solids (TDS) values (1 mS/m – 8 mS/m) as is expected for highly leached soils in humid, tropical climates. In general, the water quality meets World Health Organisation (WHO) standards and has low dissolved solids concentrations. Nonetheless, elevated sulphate concentrations and depressed pH conditions

are observed around the MSP secondary tailings areas, especially in the vicinity of the chemical tailings pond. Tailings leachate qualities exceeded the WHO guidelines for aluminium (Al), manganese (Mn), nickel (Ni), cadmium (Cd) and uranium (U). The tailings water Electrical Conductivity (EC) ranges from 12 mS/m – 35 mS/m.

According to Knight Piesold (2008), the greatest impact of mining has been the alteration of the surface water flows due to the creation of the historical mining ponds. Some of these ponds act as a water supply for the mine and the local population. Groundwater levels are expected to fluctuate in response to the mining pond levels. The maximum pond water level elevations are controlled by spillways.

## 5.2 Site Visit Memo (SRK, 2013)

This memo describes the details of a site visit undertaken by SRK to review the water aspects of the SRL operations in 2012. Additional information included in this document is as follows.

The Lanti dredge pond has a lower pH (pH 4.1) and higher EC (15 mS/m) than the background surface water quality. However, the historical mining ponds (Pejebu) improve in quality once mining ceases, with an increase in pH (pH 6) and decrease in EC (8 mS/m) due to dilution from rainfall and groundwater inflows. The poorest surface water quality is associated with the tailings facilities at the MSP.

The document describes the coastal aquifer as an additional aquifer not described previously in the Knight Piesold (2008) report. It is mentioned that the location of the freshwater/seawater interface is unknown. Data for the weathered/fractured basement aquifer is noted to be absent and is indicated as a requirement for future groundwater modelling.

The depth to groundwater as measured in three boreholes is <10 m below ground level and is expected to be shallower towards the west within the coastal aquifer. The higher EC readings in some of the boreholes were attributed to possible contamination from pit latrines.

Mention is made of dewatering which would be required once the dry mining reached the ambient groundwater level. Slope stability and flooding of the dry mining operations were identified as potential risks if the dewatering measures were inadequate.

Villagers' access water through hand dug wells, boreholes and surface water including the historical mining ponds.

Potential pollution sources identified at the MSP include:

- Underground fuel storage tanks;
- Power plant;
- Fuel depot (Marine Fuel Oil (MFO) and diesel);
- Oil traps;
- Domestic waste site;
- Workshops and cleaning bays;
- Old sewage works;
- Sulfide Tailings Stream (SFT), and
- Relatively inert Coarse Electrostatic Tailings (CET) and Fine Electrostatic Tailings (FET).

Potential pollution sources identified at the Lanti dredge include:

- Lubricants;
- Suspended solids due to the dredging operations, and
- Poorer water quality in the active dredge pond including lower pH, higher EC, elevated Al and iron (Fe) and radioactivity associated with zircon and monazite minerals.

Potential pollution sources identified at the dry mining included:

- Diesel spills from trucks and excavators; and
- Potential saline ingress where dry mining occurs in close proximity to the estuary.

Potential pollution sources identified at Nitti Port included:

- MFO and diesel lines from the barges to the above ground storage tanks which are not well banded, and
- Sewage from soak ways.

### **5.3 Water Quality Monitoring Protocol for Sierra Rutile Mine (SRK, 2013)**

This document describes the site-specific water monitoring protocol required to monitor the mine activities or infrastructure that could potentially impact on water resources in terms of quality. It is intended for use by those involved in the collection of ground and surface water samples at SRL. The objective of the water monitoring program at SRL is to monitor and assess ground and surface water

resources to provide data on existing mining operations and collect baseline data for future mining operations.

A number of issues highlighted in this protocol have already been described in the site report as referenced above. The document will not be reiterated here, and the reader is referred to that text for further information in this regard.

## 6 SITE DESCRIPTION

### 6.1 SR Area 1 Mining Operations

A site locality plan is shown in **Figure 1-1**. It can be seen that the following mining operations are located within SR Area 1:

- Historical mining ponds;
- MSP;
- Lanti wet mining;
- Lanti dry mining (including Gbeni), and
- Gangama dry mining.

The historical mining ponds were created by damming the river valleys behind engineered earthen walls to facilitate dredge mining within the alluvial sediments. Mining no longer takes place within these ponds which are now used by the local population as a domestic water source. The current planning is to drain all ponds to a level at which stability risks to the retaining dams are acceptable in the long term (SRK, 2018).

The MSP processes the Heavy Mineral Concentrate (HMC) from the various mining operations and disposes process tailings adjacent to the Mogbwemo pond. Some of the tailings have a high sulphide content and are acid generating. The MSP will most likely continue operation after the cessation of mining within SR Area 1 to process ore from other SRL tenements.

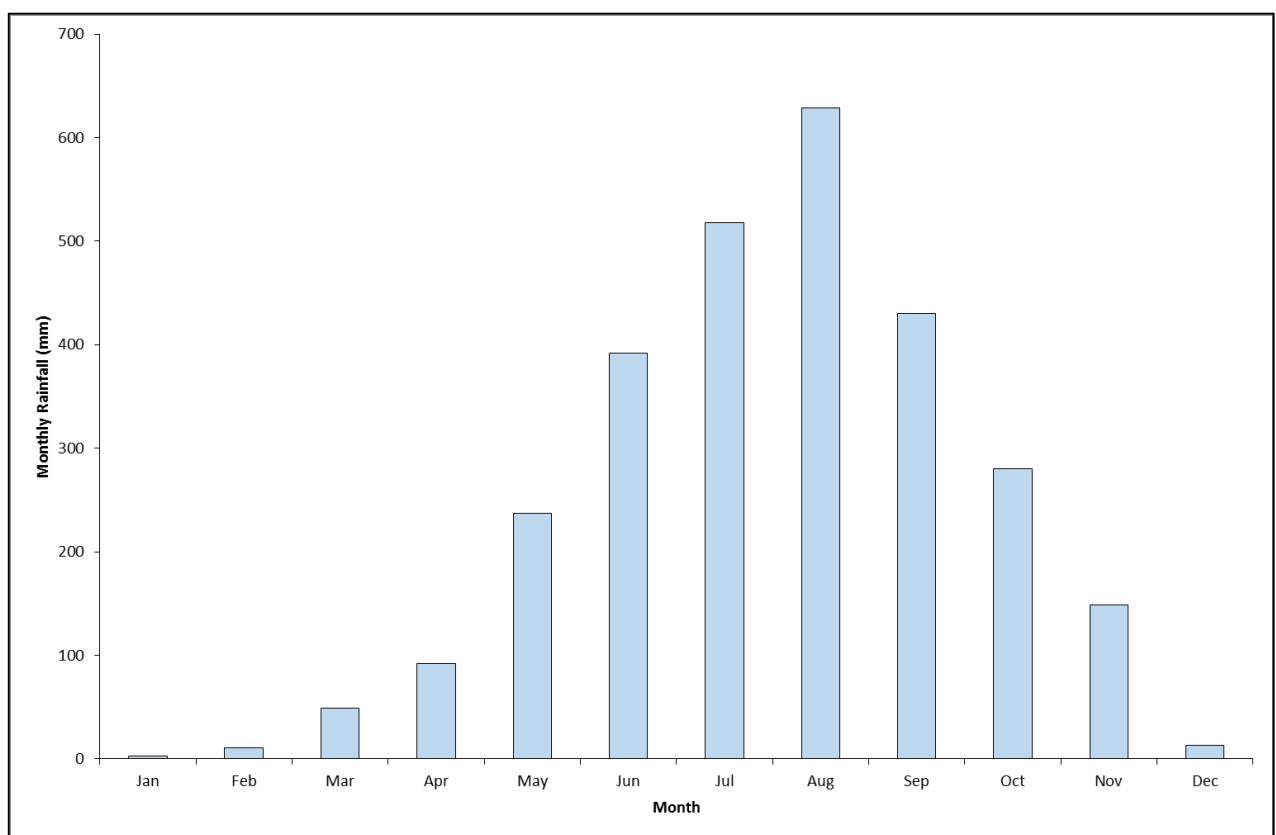
The Lanti wet mining operation is located within the southern extremity of SR Area 1. This operation consists of a dredge and a wet plant to generate a HMC. The HMC is taken to the MSP for further processing. It is anticipated that the remaining Life-of-Mine (LOM) of the Lanti wet mining is of the order of 18 months (from July 2017).

The Lanti dry mining sources ore from the Gbeni opencast pit. This mining has historically been undertaken by conventional load and haul using trucks and excavators. The ore is sent to the dry mining processing plant where the heavy mineral ore is concentrated prior to transportation by road to the MSP. An in-pit mining unit was commissioned during December 2017. This unit consists of dozers which pushes ore towards an excavator. The excavator lifts the ore into a hopper whereby it is pumped to the dry mining concentrator. It is anticipated that the remaining LOM of the Lanti dry mining operation is of the order of seven years.

The Gangama dry mining operation is located along the western edge of SR Area 1 and is orientated north-west to south-east. This mining operation is undertaken by trucks and excavators. The remaining LOM is anticipated to be four years for this operation.

## 6.2 Rainfall

Golder (2017) has processed the available rainfall data for the MSP, Lanti and Gangama. The Mean Annual Precipitation (MAP) for the MSP from 2001 to August 2017 is in the order of 2 804 mm of which 80% falls within the wet season months from June through to October (See **Figure 6-1**).



**Figure 6-1: MSP Average Monthly Precipitation (after Golder, 2017)**

## 6.3 Regional Topography and Drainage

The regional topography and drainage for SR Area 1 is shown in **Figure 6-2**. It can be seen that the topography is dominated by the north-west to south-east trending watershed consisting of the Imperi Hills, which rise to an elevation of 314 metres above mean sea level (mamsl) above the undulating plains.



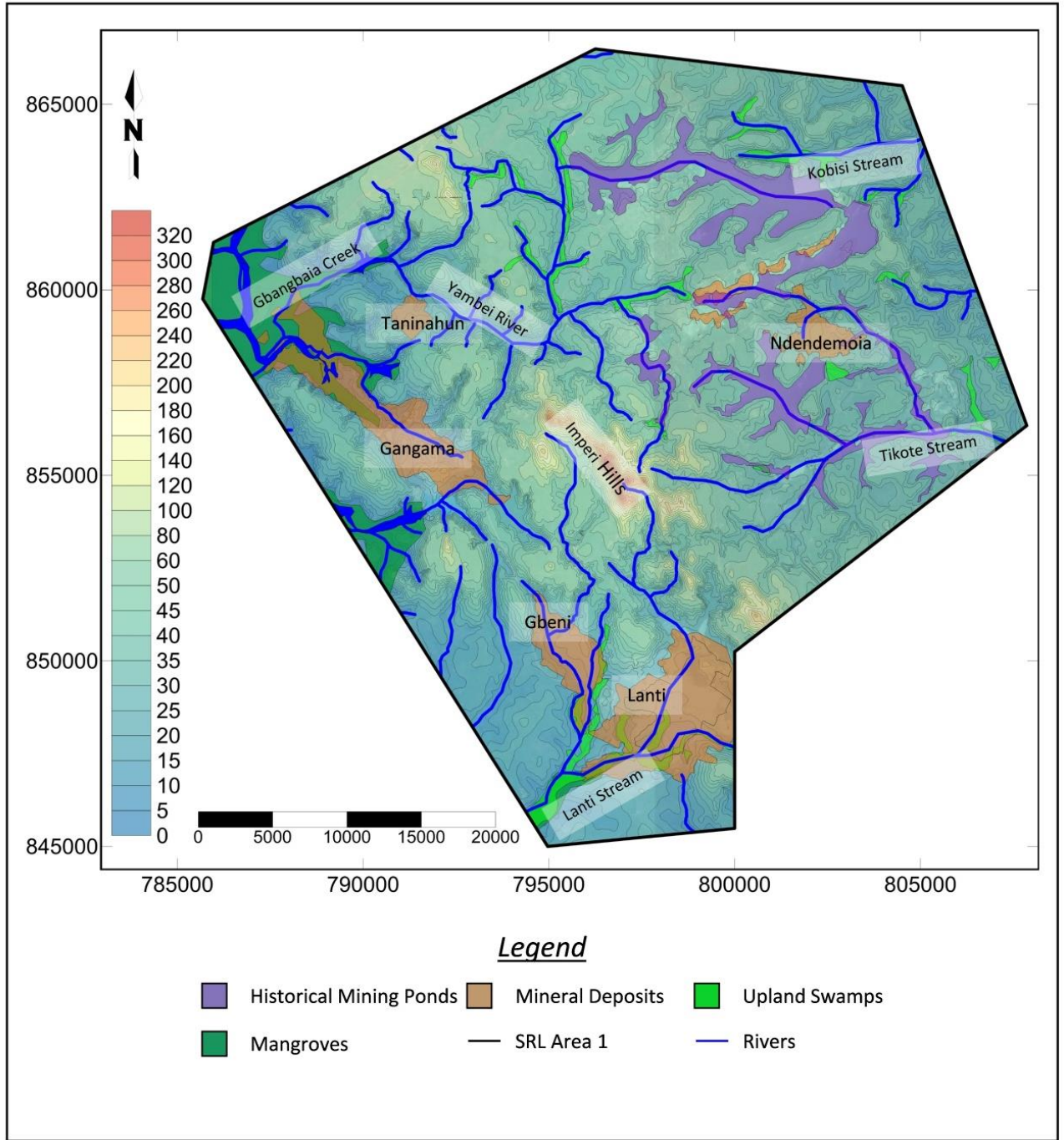


Figure 6-2: SR Area 1 - Topography and Drainage

Topographic gradients to the north-east of the Imperi Hills range from 2% to 3.5% in contrast to the area to the south-west where gradients range from 2% to 7%.

According to SRK (2018), the SR Area 1 surface river system drains in three different directions as follows.

- The MSP catchment system which is east of the SR Area 1 lease boundary, consists of three of the catchment river systems (Kopa, Tikote, and Kokpoi stream), which flow east into the Jong River;
- The Lanti catchment system includes the Gbeni and Lanti streams. Gbeni stream is located on the southern portion of SR Area 1 and it flows to the southwest before joining the Lanti stream to form Teso Creek. The Teso Creek flows into the Sherbro River which eventually flows into the sea. The Teso Creek is influenced by tidal action, and
- The Gangama catchment river system (Gbangbaia Creek, Jangalo Creek and Gbangbatoke), is located west of SR Area 1. The catchment drains in Gbangbaia Creek which flows into Bagru Creek. The Bagru Creek flows to Sherbro River which then flows into the sea.

The surface water drainage systems in SR Area 1 have been significantly affected by the historical mining ponds which are largely ponded areas now (SRK, 2018). The outflows into the natural river systems are via spillways from these impoundments.

#### 6.4 Tidal Fluctuations

According to the New Partnership for Africa's Development (NEPAD, 2005), the tidal fluctuations in Sierra Leone are as follows:

*"The Highest Astronomical Tide or maximum tidal range goes up to 3.38 m above the Lowest Astronomical Tide or the Admiralty Chart Datum. Mean High Water Springs (MHWS) are 3.0 m above Chart Datum whereas Mean Low Water Springs (MLWS) are 0.40 m above Chart Datum. Mean High Water Neaps (MHWN) are 2.30 m above Chart Datum whereas Mean Low Water Neaps (MLWN) are 1.0 m above Chart Datum"*

The spring tidal range up to 3 m will influence water ingress during the Gangama mining operations within close proximity to the estuary.

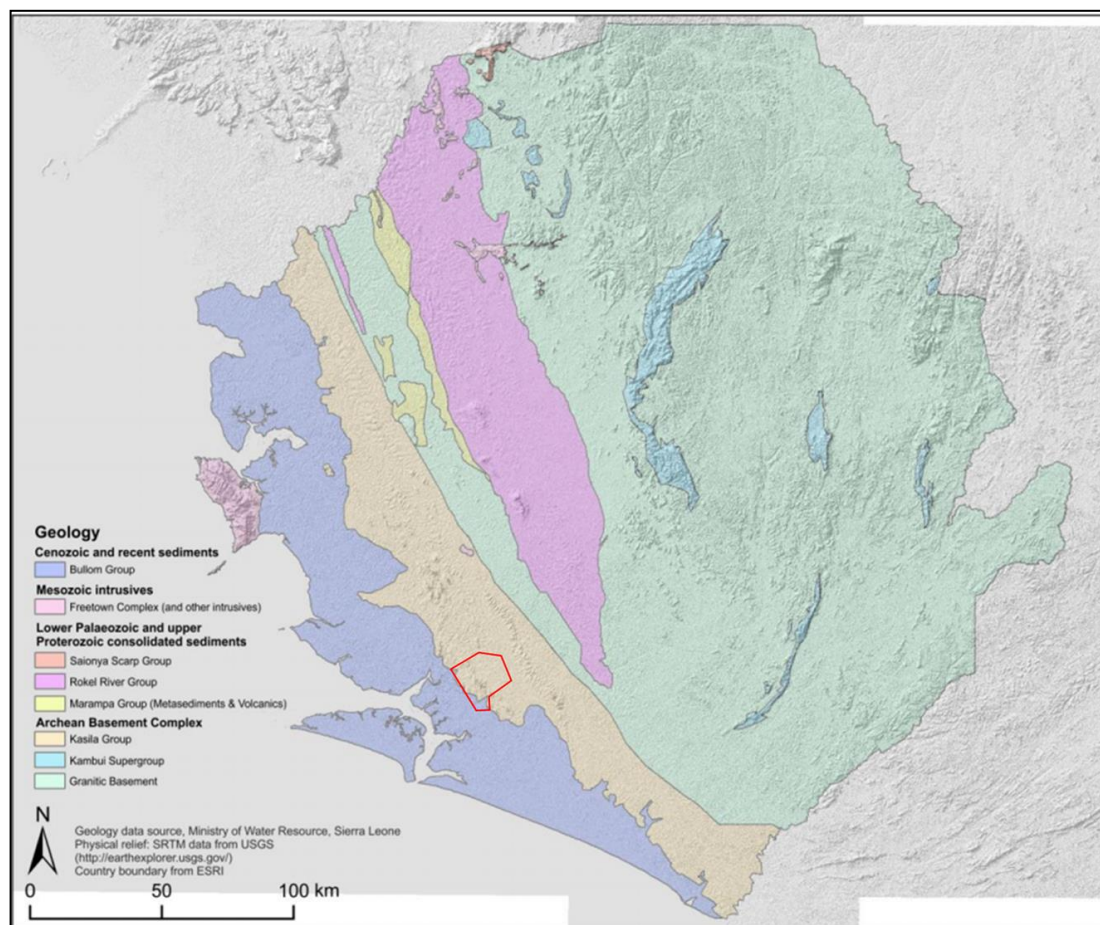
## 7 GEOLOGICAL SETTING

### 7.1 Regional Geology

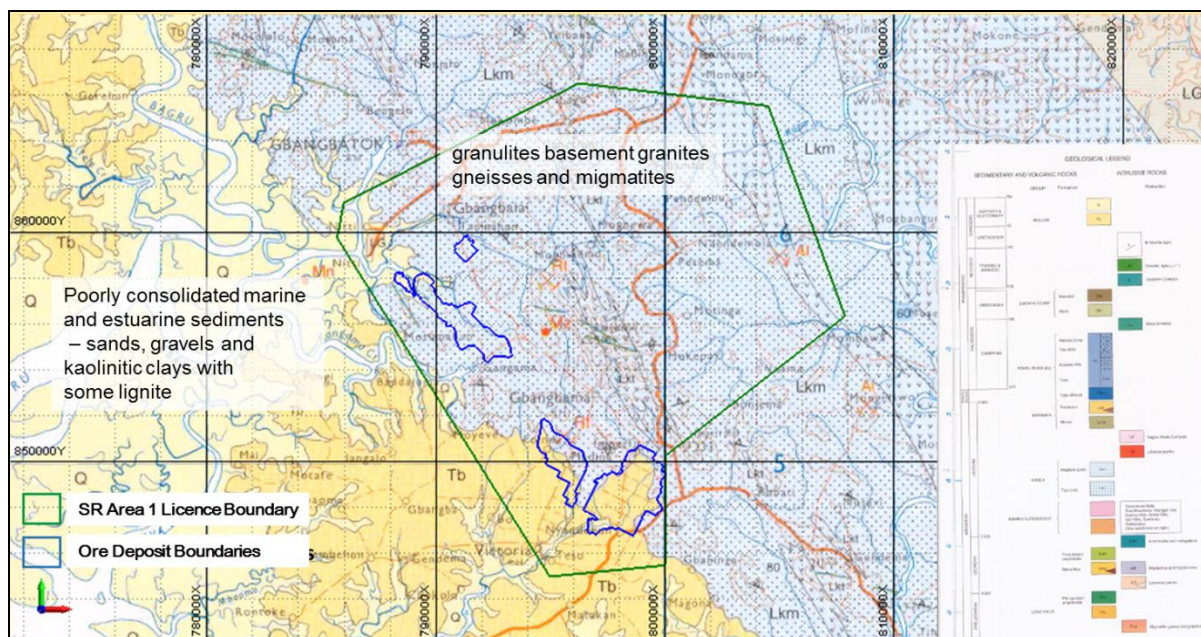
The current understanding of the SR Area 1 geology is described in Button (2011). According to this author, Sierra Leone may be subdivided into 3 geological zones namely:

- The eastern side of the country which forms part of the stable Precambrian west African craton;
- The western unit contains elements of an orogenic belt that was deformed during the Pan-African tectono-thermal event about 550 Million years ago, and
- A 20 km – 40 km coastal strip which comprises Pleistocene to Recent sediments.

The juxtaposition of the three zones in relation to SR Area 1 is shown in **Figure 7-1**. A more detailed geological map indicates the location of the Tertiary Bullom Group of sediments in relation to SR Area 1 as shown in **Figure 7-2**.



**Figure 7-1: Sierra Leone Regional Geology**



**Figure 7-2: SR Area 1 Geological Map**

It can be seen from **Figure 7-2** that the majority of SR Area 1 is underlain by gneisses of the Kasila Group. The Bullom sediments are located on the western and south-western boundary of SR Area 1.

## 7.2 SR Area 1 Geology

Knight Piesold (2008) has described the local geology as Tertiary aged alluvial deposits overlying the Precambrian high-grade quartzo-feldspathic-garnet gneiss (charnockite).

According to Button (2011), the SR Area 1 heavy mineral sands placer deposits are hosted in the Bullom sediments which were deposited following a Tertiary marine regression with sea levels some 100 m below current levels. Mechanical and chemical weathering liberated heavy minerals from the underlying Kasila Group which were deposited in pre-incised channels.

Estuarine and marine unconsolidated sediments are located to the west of the major watershed located within the centre of SRL Area 1 (Button, 2011). In contrast, alluvial and colluvial sediments were deposited sub-aerially to the north-east of the watershed. Several cyclic sequences comprising poorly sorted clastic gravels overlain by sands and clayey silts are preserved. Hard lateritic inclusions are common but are generally associated with the upper portions of the sequence.

The heavy mineral sands are generally angular and display little evidence of transport over long distances or extensive reworking. Grades rapidly decrease downstream, with sand replacing the argillaceous material within the matrix.

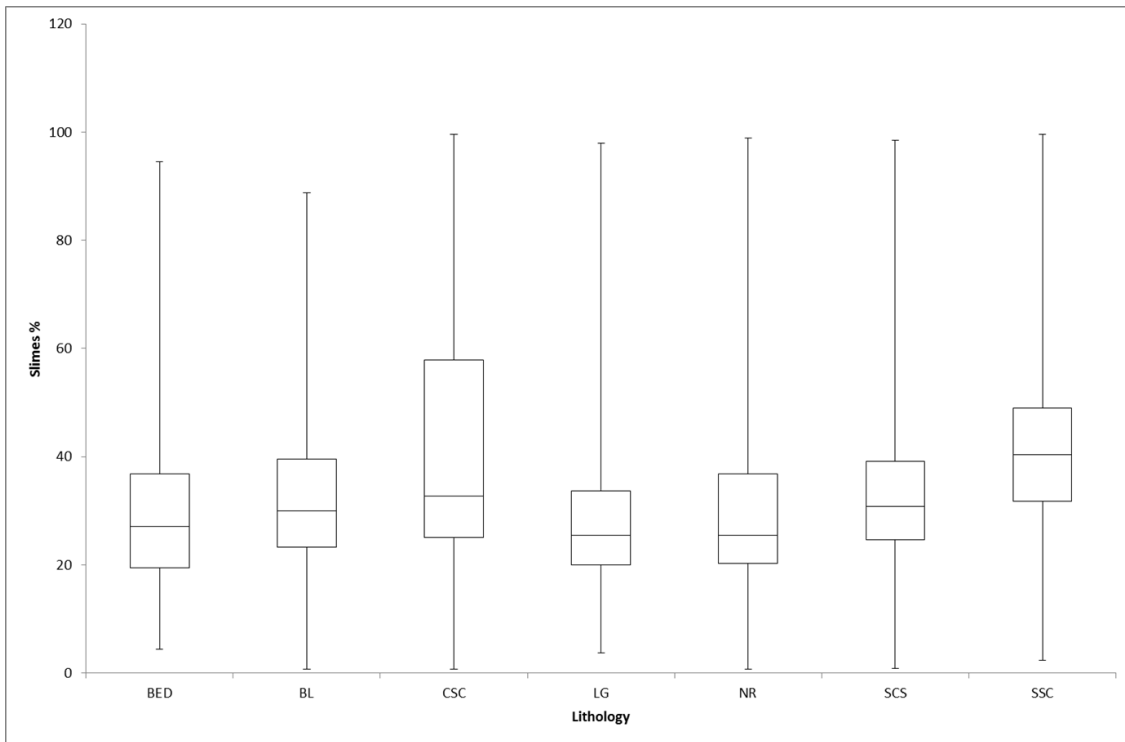
SRL has subdivided the ore deposit geology into lithological descriptions as shown in **Table 7-1**:

**Table 7-1: SRL Lithological Codes**

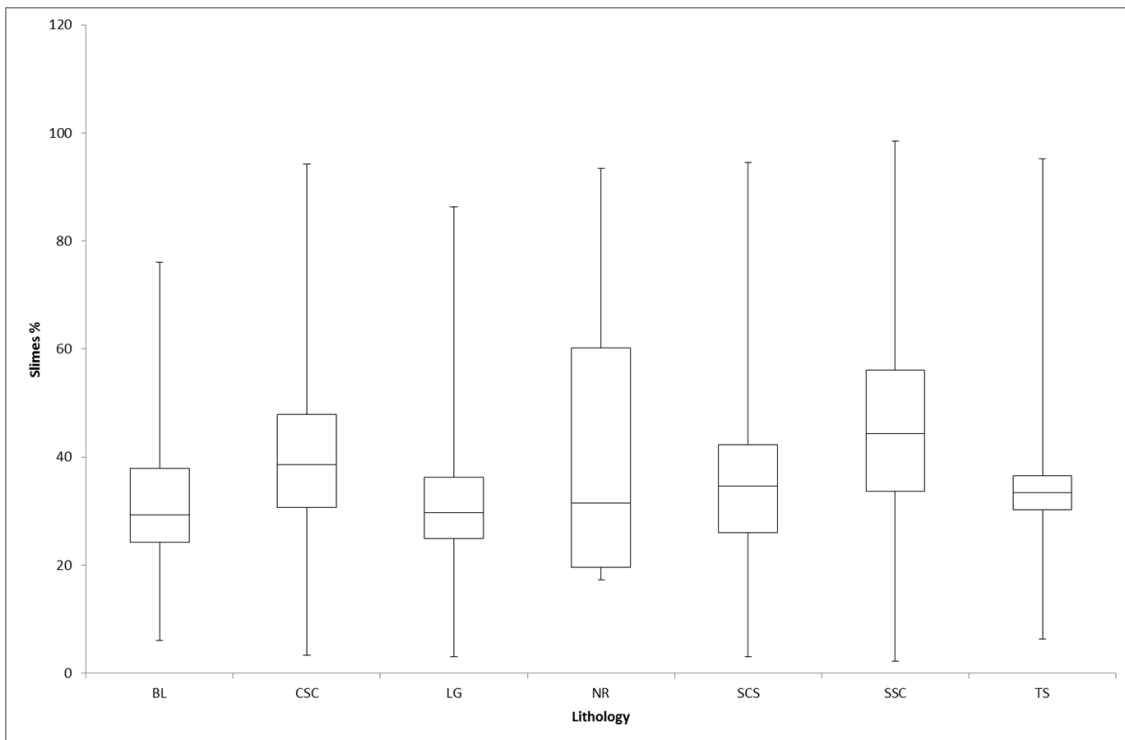
Code	Lithology	Description
TS	Top Soil	Lateritic/clayey/sand topsoil type deposits with organic material.
LG	Lateritic Gravel	Reddish brown unstructured to massive clast supported pebbly gravel with sandy matrix.
BL	Blocky Laterite	In situ laterite unit, nodular to irregular at top, grading to iron staining over a few metres.
CSC	Clayey/Sandy Clay	Mottled red, white and mauve, indicating bioturbated unit. Clay component is generally more silt than clay; contains lateritic concretions. Comprises part of the ore horizon.
SCS	Sandy/Clayey Sand	Mottled red, white and mauve bioturbated unit, may contain coarse sand and gravel components. Comprises part of the ore horizon.
SSC	Sandy/Silty/Stiff Clay	Grey bioturbated clays, grading to sandy clays laterally and vertically.
BED	Bed Rock	Decomposed bedrock retrogressed to clay mineralogy.
NR	No Recovery	Insufficient sample recovered for logging.

A comparison between the slimes content and the various lithological units was undertaken for the Gangama and Gbeni dry mining deposits as shown in **Figure 7-3**. It can be seen that the slimes content is similar between the SRL lithological categories. This suggests that the SRL geological logging does not provide an indication of lower or higher permeability zones. Although the slimes content is also similar between the two deposits, the Gbeni deposit has a slightly higher slimes content on average.

At the suggestion of the SRL Resource Geologist (Pers. comm, 2017), the location of the geological block model centres where the slimes percentage is greater than 60% was also analysed as shown in **Figure 7-4**. It can be seen that the centres greater than 60% slimes for the Gangama deposit are located to the north-west adjacent to the mangroves. This is in contrast to the Gbeni deposit where the centres greater than 60% slimes are located in the bedrock depression adjacent to the river in the south-west. Nonetheless, it is evident that there is no distinct high slimes horizon in either deposit that may be used as a hydrostratigraphic unit.

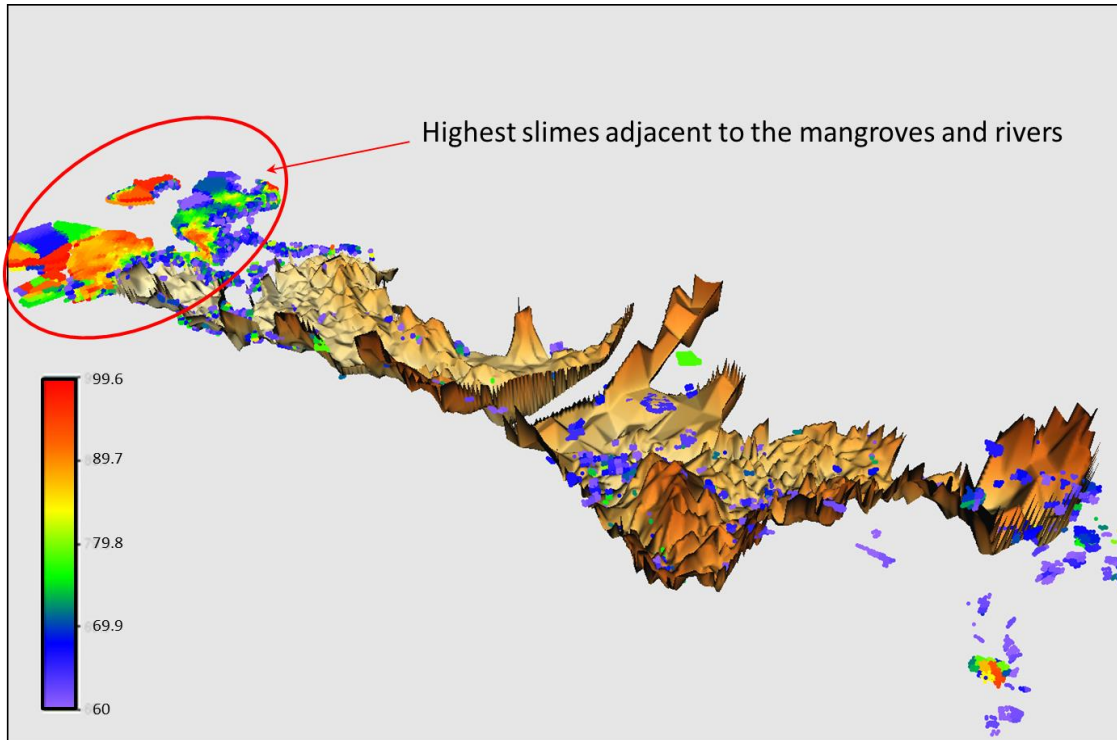


Gangama Deposit Block Model Slimes % vs Lithology

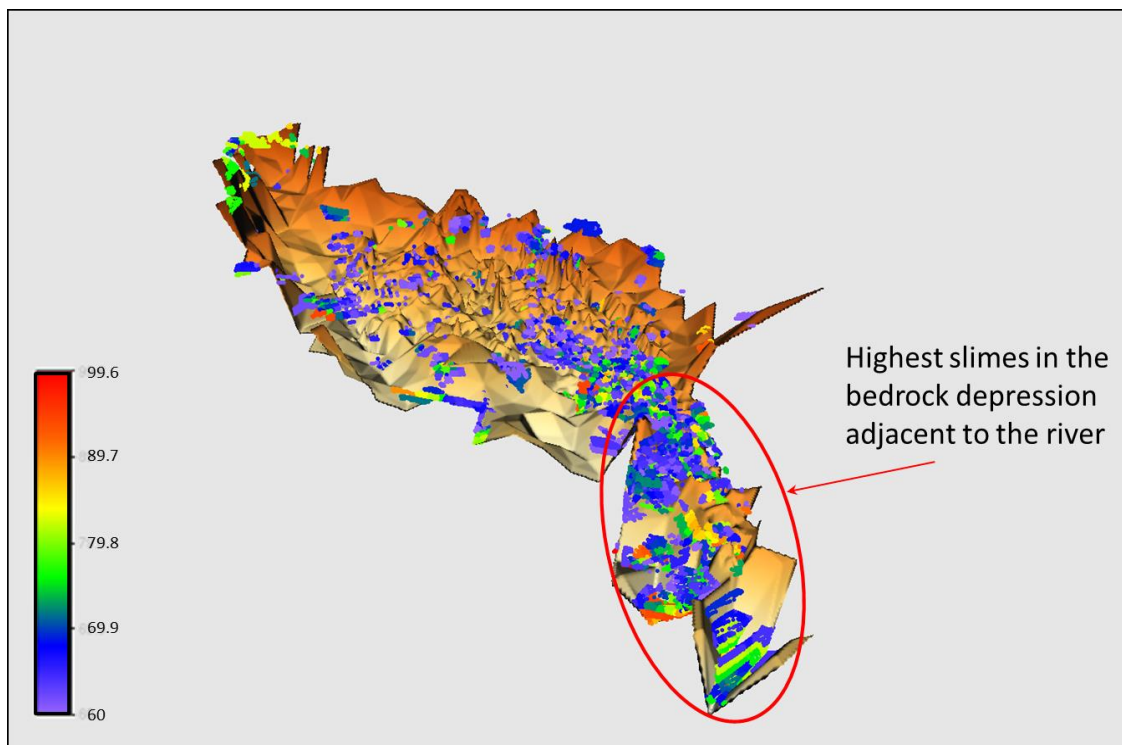


Gbeni Deposit Block Model Slimes % vs Lithology

**Figure 7-3: SRL Geological Block Model Slimes % vs Lithology**



Gangama Deposit Block Model Centres Slimes >60%



Gbeni Deposit Block Model Centres Slimes >60%

Figure 7-4: Gangama and Gbeni Deposits Block Model Centres >60% Slimes

## 8 HYDROGEOLOGY

The SR Area 1 hydrogeology can be described in terms of the hydrostratigraphy, observed groundwater levels, aquifer parameters, groundwater users and hydrochemistry. Some of the data has been obtained from SRL, whereas other information has been generated during the course of this investigation including geological logs, pumping tests and observed groundwater levels.

### 8.1 Monitoring Borehole Drilling

A total of 19 monitoring boreholes were drilled during the course of this investigation (See **Figure 8-1**). The sites were selected to evaluate ambient groundwater conditions away from the mining operations and the impact of the historical mining ponds on the groundwater regime. Some emphasis was also placed on the Gangama and Gbeni dry mining deposits with the installation of borehole pairs to monitor the groundwater levels within the orebody and the underlying weathered/fresh basement contact respectively.

Boreholes monitoring ambient groundwater conditions are located on the northern and south eastern boundary of SR Area 1 distant from any historical, current or planned mining operations. The boreholes monitoring the historical mining ponds are located on the watersheds immediately adjacent to these features so that any groundwater fluctuations in response to the mining pond levels may be determined. Borehole pairs drilled in the Gangama and Gbeni dry mining deposits monitor the groundwater response within the orebody and the underlying weathered/fractured basement contact to dewatering.

Given the generally low yield/water strikes within the unconsolidated sediments, the boreholes were generally screened throughout from 3 m below surface to the fresh basement. In the dry mining areas, the shallow boreholes that were drilled into the orebody were screened throughout whereas the deeper boreholes drilled into the weathered/fresh basement contact were only screened across this zone with the remainder of the hole constructed with plain casing to surface. A gravel pack was installed across the screened casing while a concrete seal was installed across the solid casing to surface. The borehole logs for this study are shown in Appendix A.

The details of the boreholes drilled during this investigation are presented in **Table 8-1**. Hole depths range from 9 m to 40 m with an average depth of 24 m. The hydrogeological characteristics of the drill holes will be described in the following sections.



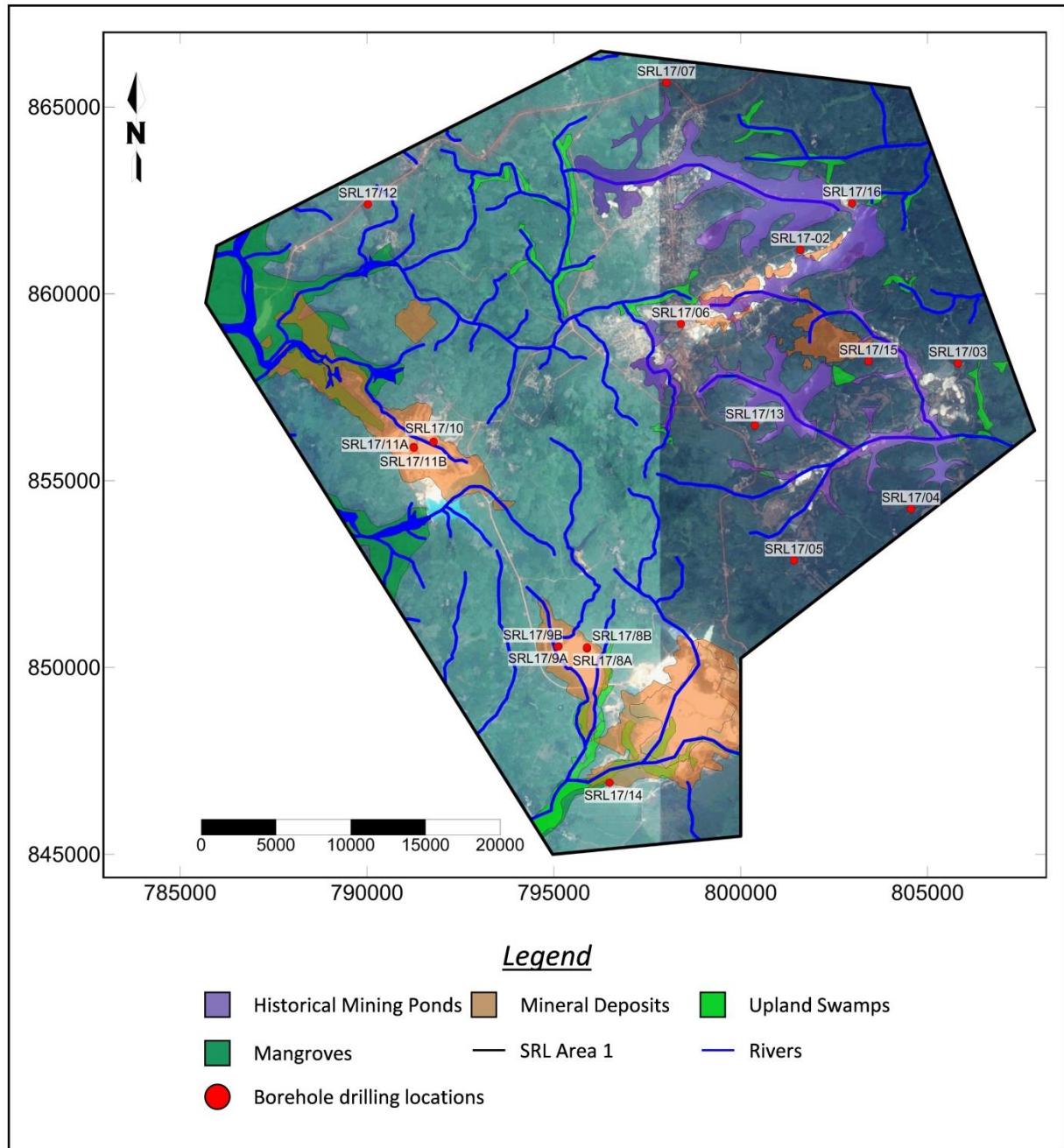


Figure 8-1: SR Area 1 Monitoring Borehole Drilling Locations

Table 8-1: SR Area 1 Monitoring Borehole Drilling

X	Y	Z	BH-ID	Depth (m)	GW (mbc)	GW (mamsl)	Laterite Thickness (m)	Weathering Depth (m)	Blow Yield l/sec
802009	867469		SRL17-01	28	12.00		5	21	0.72
801595	861180	52.48	SRL17-02	30	11.40	40.58	5	28	4.00
805814	858139	44.92	SRL17/03	25	9.81	34.61	2	9	
804557	854242	38.78	SRL17/04	40	4.89	33.39	10	34	
801426	852866	44.34	SRL17/05	20	7.05	36.79	5	20	2.50
798398	859191	52.71	SRL17/06	23			8	20	20.00
798013	865651	56.02	SRL17/07	35	8.61	46.91	6	30	5.50
795886	850511	21.00	SRL17/8A	9	2.00	18.50	0		
795887	850536	20.95	SRL17/8B	25	3.78	16.67	0	20	2.00
795123	850565	14.00	SRL17/9A	12	3.45	10.05	1		
795106	850559	13.95	SRL17/9B	28	3.48	9.97	4	25	1.86
791782	856043	11.16	SRL17/10	20	5.40	5.26	0	20	10.00
791250	855902	11.72	SRL17/11A	15	6.43	4.79	0		0.50
791255	855877	11.64	SRL17/11B	27	6.16	4.98	0	27	6.00
790024	862395	74.75	SRL17/12	15	9.68	64.57	3	12	
800377	856477	50.00	SRL17/13	25	9.49	40.01	8	25	4.50
796494	846914	13.11	SRL17/14	34			0	34	32.00
803421	858193	40.22	SRL17/15	30	6.71	33.01	3	30	1.75
802975	862423	49.50	SRL17/16	20	12.03	36.97	0	20	2.50

Meters below collar (mbc)

## 8.2 Hydrostratigraphy

The geology underlying the site has been described as Tertiary to Recent sediments overlying the gneissic basement of the Kasila Group. Drilling during this investigation has shown that the groundwater occurrence within the fresh basement is limited to isolated fractures and the yield is generally very low. For this reason, this is considered to be the effective base of the hydrogeological regime within SR Area 1.

Although laterite is extensive with an average thickness of 4.29 m, it has been removed during dry mining in Gangama and Gbeni. This material is generally confined to the unsaturated zone above the groundwater surface and therefore does not form part of the hydrostratigraphy. Nonetheless, the laterite distribution does influence the groundwater recharge across the study area.

Since there has been limited transportation of the Tertiary to Recent sediments, they tend to be clayey silts and silty clays similar in characteristic to the weathered basement. For this reason, the unconsolidated material, including the weathered basement, is grouped together as one

hydrostratigraphic unit. The base of this unit ranges from 9 m to 34 m below surface with an average depth of 23.44 m. Bullom sediments in the coastal strip tend to have a higher permeability. However, these areas would be assigned different hydrogeological characteristics in any subsequent groundwater modelling rather than defining them as a separate hydrostratigraphic unit for the purpose of this investigation.

The highest groundwater yields besides the Bullom sediments, are found at the weathered/fresh basement contact zone. This is considered to be a separate hydrostratigraphic unit which has a thickness of approximately 2 m to 3 m.

The effective hydrostratigraphy for SR Area 1 may therefore be summarized as follows:

- Unconsolidated Tertiary and Recent sediments, Bullom strata and weathered basement, and
- The contact zone between the weathered and fresh basement.

### 8.3 Observed Groundwater Levels

Groundwater levels are not currently measured in the SR Area 1 community boreholes. Preliminary observed groundwater levels in the monitoring boreholes drilled during this investigation range from 2 mbc to 12 mbc with an average depth of 7.20 mbc. The shallower groundwater levels are concentrated within the Gangama and Gbeni dry mining areas as shown in **Figure 8-2**. This may be a function of the removal of ore that has already taken place. However, this could also be attributed to the location of the deposits within topographic lows - which would typically be groundwater discharge zones.

Groundwater gradients tend to mimic the topography under ambient conditions. The potential influence of the historical mining ponds and current mining operations on the groundwater gradients has been investigated by plotting the topography against groundwater levels as shown in **Figure 8-3**. There is a very good correlation (0.98) between the topography and groundwater levels. At this stage it would appear that mining has not significantly altered the expected ambient groundwater gradients. However, this may change in the future as dry mining deepens below the regional groundwater levels. It is also important to note that borehole SRL17/02 has a similar groundwater elevation to that of the surrounding historical mining ponds. It is possible that the groundwater levels may lower in response to the lowering of the historical mining pond water levels as part of any closure plan.

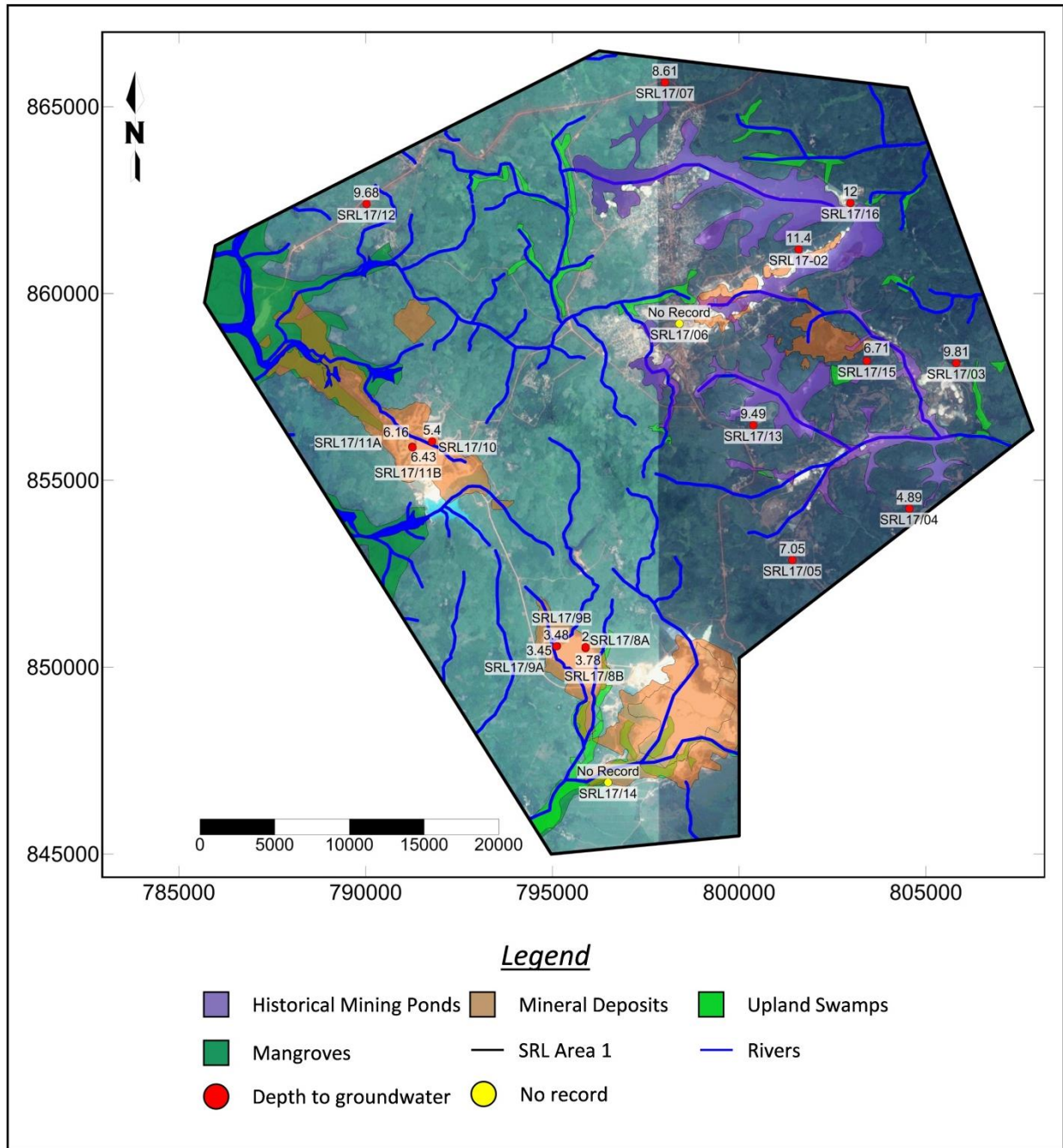


Figure 8-2: SR Area 1 Depth To Groundwater (mbc)

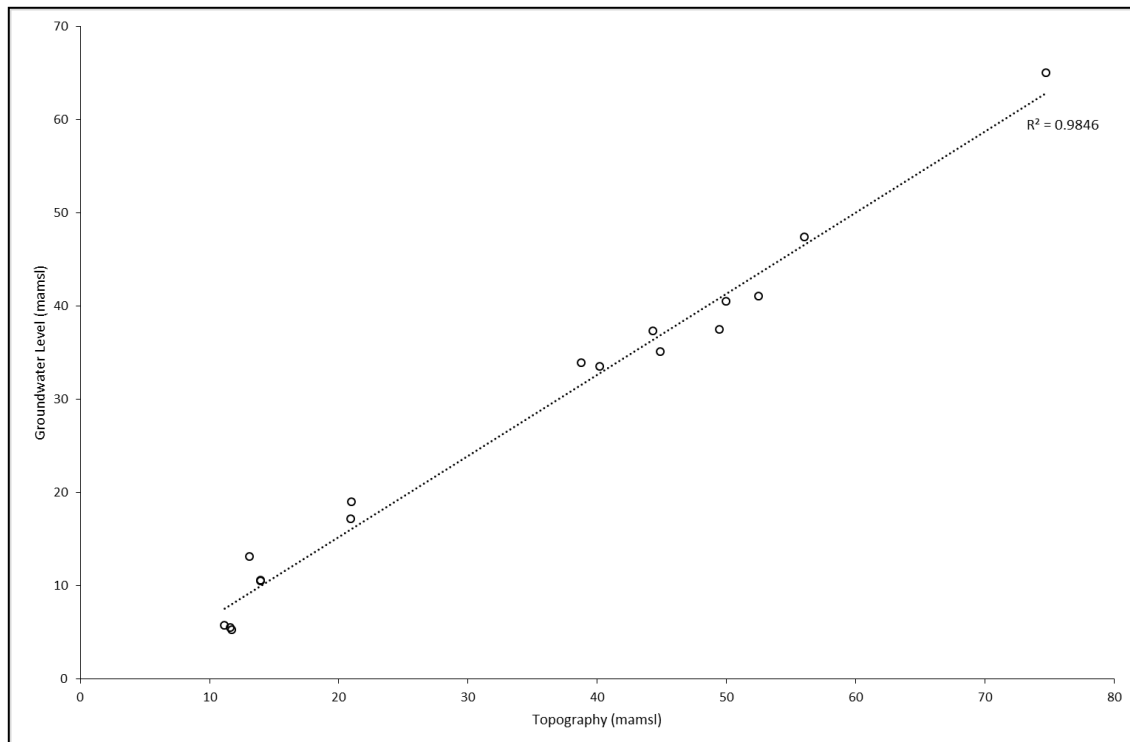


Figure 8-3: SR Area 1 Topography vs Groundwater Level (mamsl)

#### 8.4 Aquifer Parameters

Borehole blow yields provide an indication of the permeability distribution across SR Area 1 as displayed in **Figure 8-4**. It can be seen that the majority of the blow yields range from 0.5 l/sec to 6 l/sec with an average of 2.9 l/sec. Exceptions include SRL17/06 (20 l/sec), SRL17/10 (10 l/sec) and SRL17/14 (32 l/sec). The latter borehole is associated with the Bullom sediments. Lower blow yields in the dry mining areas are attributed to the clayey silty nature of the ore deposit.

Pump tests have been undertaken on the majority of the monitoring boreholes drilled during this investigation as shown in **Table 8-2**. The three exceptional boreholes SRL17/06, SRL17/10 and SRL17/14 could not be pump tested since the yield exceeded the pump capacity. The decision whether to pump test these holes in future will be undertaken once the groundwater modelling has been completed.

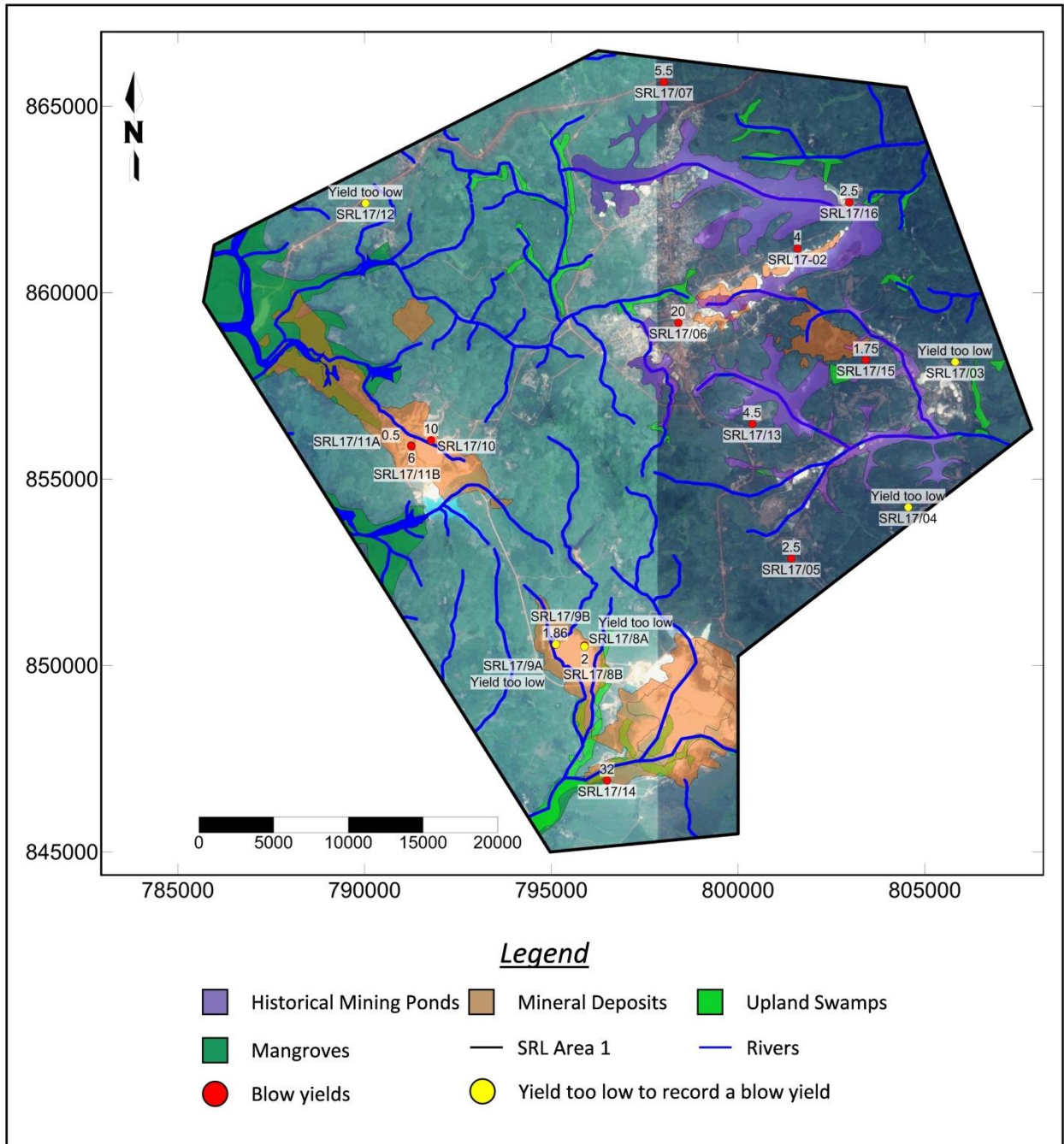


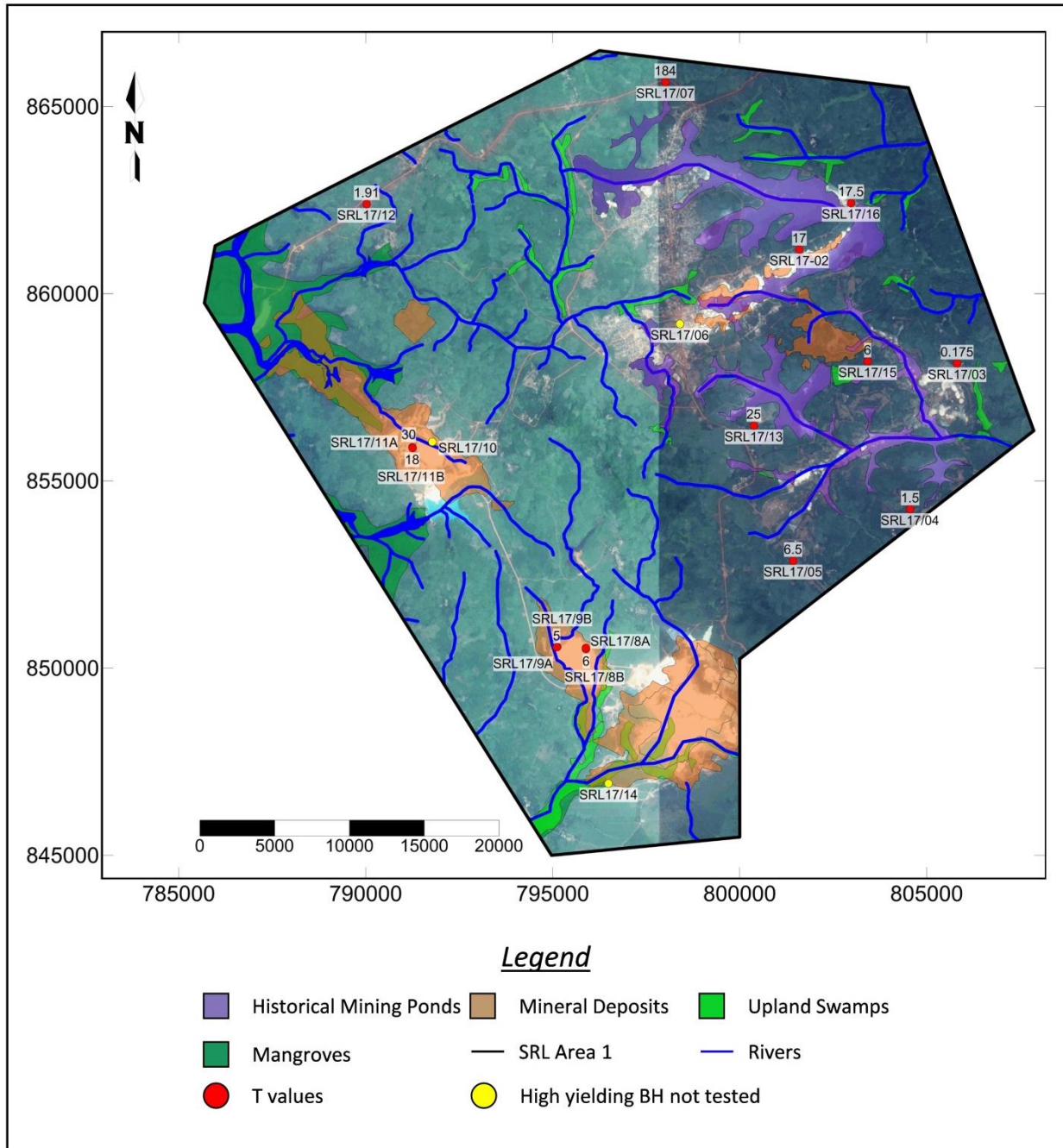
Figure 8-4: SR Area 1 Blow Yields (l/sec)

Table 8-2: SR Area 1 Pump Testing Results

BH-ID	Pumping Duration (min)	Pumping Rate (l/sec)	Pumping T (m <sup>2</sup> /day)	Recovery T (m <sup>2</sup> /day)	Slug Test K (m/day)
SRL17-01	120	0.45	4	3	
SRL17-02	120	1.82	17	17	
SRL17/03	70	0.15	0.12	0.23	
SRL17/04	180	0.93	2	1	
SRL17/05	120	1.38	7	6	
SRL17/06	BH yield too high				
SRL17/07	120	1.84	214	154	
SRL17/8A					0.02
SRL17/8B	180	0.79	6	6	
SRL17/9A					0.09
SRL17/9B	180	0.79	5	5	
SRL17/10	BH yield too high				
SRL17/11A	120	0.27	50	10	
SRL17/11B	180	1.91	18	18	
SRL17/12	7	0.24	0.82	3	
SRL17/13	180	3.24	20	30	
SRL17/14	BH yield too high				
SRL17/15	180	1.2	6	6	
SRL17/16	180	1.22	17	18	

It can be seen from **Table 8-2** that there is generally agreement between the constant rate and recovery pumping tests. Exceptions include SRL17/07, SRL17/11A and SRL17/13. The relatively high transmissivity for SRL17/11A is attributed to vertical leakage from the underlying weathered/fresh basement contact. Boreholes SRL17/8A and SRL17/9A were slug tested since their yields were too low for pump testing purposes.

The transmissivity for the boreholes that were pump tested ranges between 0.12 m<sup>2</sup>/day and 214 m<sup>2</sup>/day. The distribution of the average transmissivity per borehole as shown in **Figure 8-5** is variable across the site. This is to be expected given that the major aquifer besides the Bullom strata is the weathered/fresh basement contact. The pump test curves are shown in Appendix B.



**Figure 8-5: SR Area 1 Transmissivity Distribution ( $m^2/day$ )**

SRK has undertaken surface water modelling for SR Area 1 (SRK, 2018). These simulations indicate that the effective rainfall recharge to groundwater is in the order of 0.17% - 2.61% of MAP (SRK, Pers. comm., 2017). Recharge values below 1% are lower than normally expected. However, this is attributed to the high intensity of the rainfall which promotes runoff and the laterite distribution which also reduces infiltration. The surface water simulated baseflow values will be compared to the groundwater model once this has been constructed.



## 8.5 Groundwater Users

According to Knight Piesold (2008), most surface water sources, including the historical dredge ponds, are used by local community members for a variety of domestic purposes including for drinking water. This was confirmed during the site visit as part of this investigation undertaken by Graell in July 2017. Shallow groundwater wells are also used by local community members for water supply purposes. Deeper boreholes that have been drilled by Non-governmental Organisations (NGOs) were also evident during the site visit as part of this investigation. SRK (2013) has listed a number of village/community boreholes as part of the proposed monitoring plan outlined in that document as shown in **Table 8-3**. Hole depths, borehole yields and rest water levels are not available at present. All the boreholes observed during the site visit as part of this investigation were equipped with hand pumps.

**Table 8-3: SR Area 1 Village/Community Boreholes**

X	Y	Location
797612.0	861989.0	Moriba Village Well
805471.4	858440.3	Mondorkor Village Well
800666.0	848504.0	Mokaba Village Well
798159.0	847050.0	Nyandehun Village Well
797355.0	851445.0	Yangatoke Village Well
793299.0	856337.0	Junctiola Village Well
791924.0	857435.0	Semabu Village Well
790525.0	861322.0	Gbangbama Village Well
796662.0	859280.0	Mogbwemo Village Well 2
797069.9	858955.1	Mogbwemo Village Well
798640.0	860073.0	Mogbewa Village

The location of the village/community boreholes are shown in **Figure 8-6**. It is possible that groundwater levels may lower in response to the lowering of the historical mining pond water levels as part of the current SR Area 1 closure plan. It is therefore important that the groundwater abstraction points are comprehensively identified before any adjustments to the mining pond water levels are undertaken. This includes determining the current groundwater levels where possible.

It is recommended that an updated hydrocensus be undertaken by SRL to confirm the location, groundwater levels and hydrochemistry of all groundwater extraction points within SR Area 1. The groundwater chemistry will be discussed in more detail in the hydrochemistry section of this report (see Section 8.6).

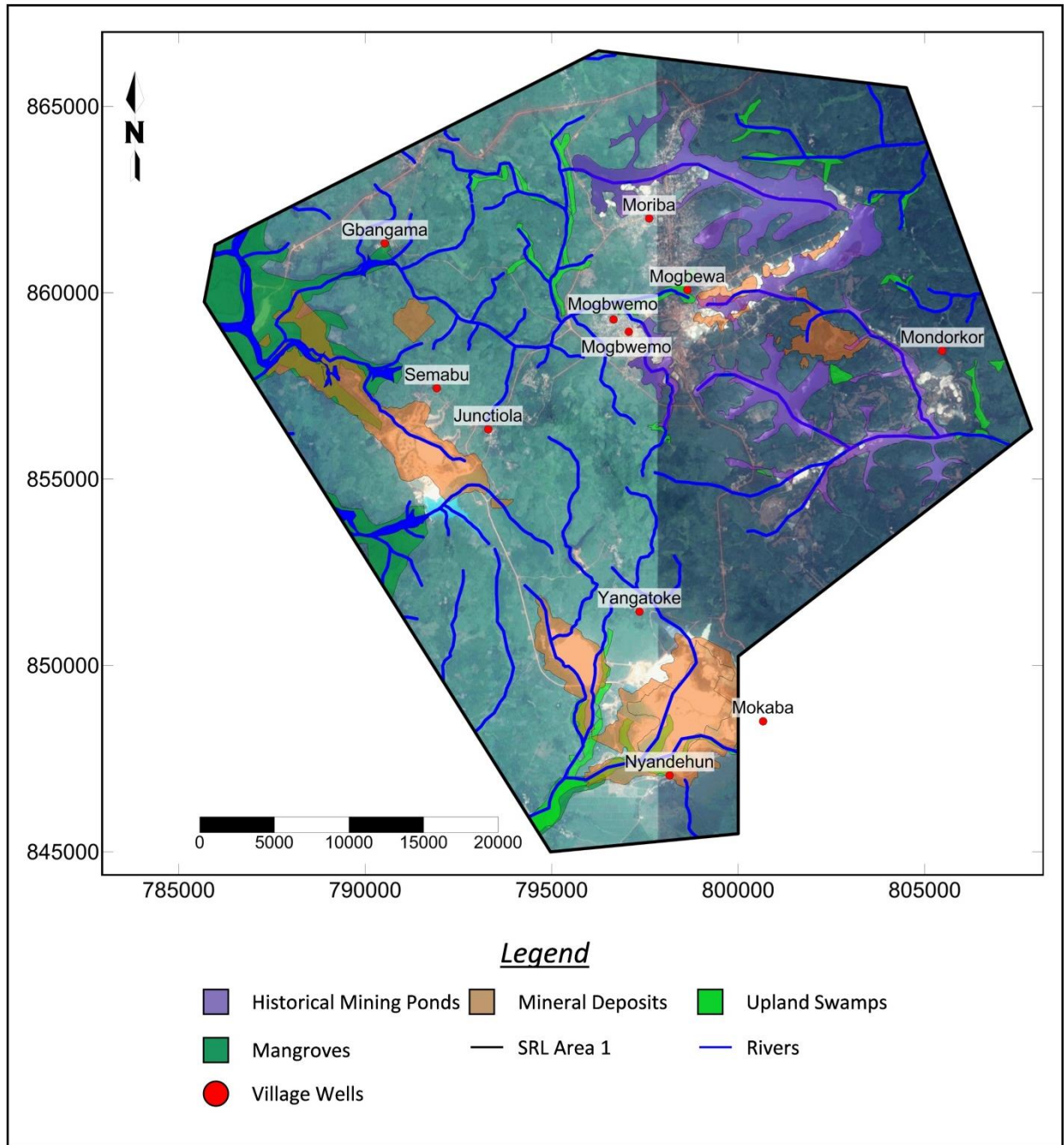


Figure 8-6: SR Area 1 Village/Community Boreholes

## 8.6 Hydrochemistry

Groundwater sampling will be undertaken as part of this investigation during 2018 to substantiate the findings of the historical water quality monitoring results from Knight Piesold (2008) and SRK (2013). However, in the absence of current monitoring data, these historic results are discussed as a preliminary assessment. The historic water quality analyses will be evaluated within the context of the Sierra Leone Environment Protection (Mines and Minerals) Regulations (2013), as well as against the WHO drinking water standards.

### 8.6.1 Potential Contamination Sources

SRK (2013) identified a number of potential contaminant sources within the SR Area 1 operations as follows.

*MSP:*

- Power Plant;
- Domestic waste site;
- Fuel Depot (MFO and diesel), underground storage tanks and oil traps;
- Workshops, cleaning bays and old sewage works, and
- Tailings streams including the SFT, CET, FET, and Total Tailings (TT).

SRK (2018) identified marcasite and pyrite in the SFT. These reactive minerals are likely to contribute to acidity when exposed to oxidising conditions.

#### *Historical Mining Ponds*

SRK (2013) has indicated that the historical mining pond water quality has improved in comparison to the pH and EC of the active Lanti mining pond. An exception is the Mogbwemo dredge pond, which is located immediately adjacent to the MSP and the associated secondary tailings disposal area. According to SRK (2013), it is anticipated that microbiological analysis would confirm high heterotrophic and total and faecal coliform counts for these water bodies.

#### *Lanti Wet Mining*

SRK (2013) indicates that the active Lanti mining pond is characterized by a pH in the order of 4 and a TDS of 60 mg/l. Elevated concentrations of Al, Cu, Fe, K, Mn, SO<sub>4</sub> and Zn in the leachate from the primary process tailings relative to background surface water levels are expected (SRK,2018). Hydrocarbon and lubricant spills also represent a potential source of contamination.

### *Gangama and Gbeni Dry Mining:*

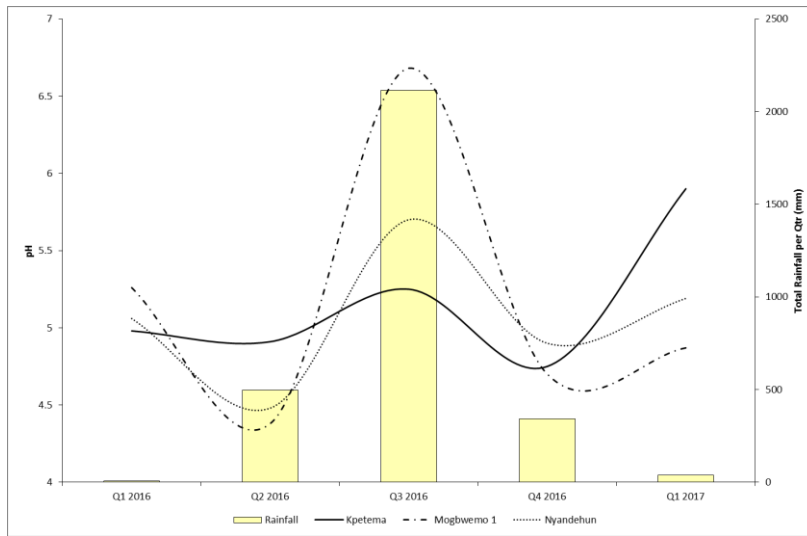
According to SRK (2018), the primary tailings are relatively inert and should not require any additional remedial measures. However, potentially elevated concentrations of Al, Cu, Fe, K, Mn, SO<sub>4</sub> and Zn in the leachate from the primary process tailings relative to background surface water levels are expected. Hydrocarbon and lubricant spills also represent a potential source of contamination. The potential for suspended solids to be discharged into the surface water systems from any pit dewatering due to groundwater ingress is a possibility.

#### 8.6.2 Borehole Hydrochemistry

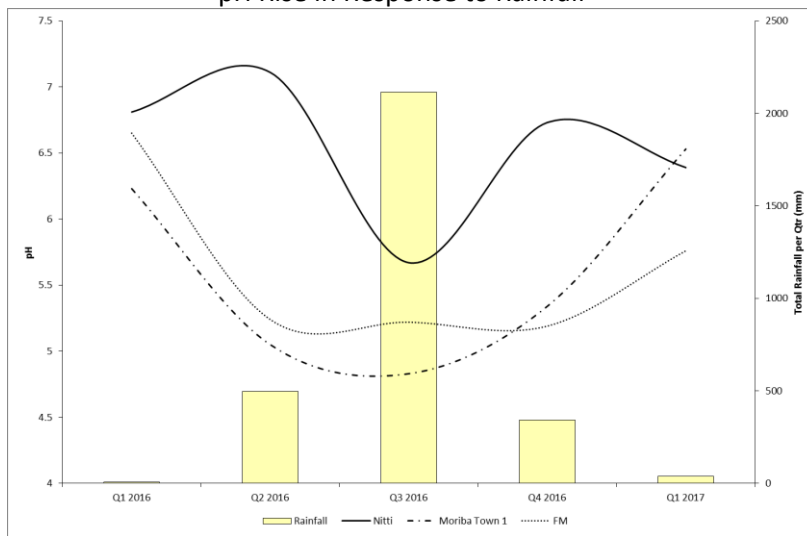
The historical groundwater monitoring provided by SRL for 2016 and the first quarter of 2017 has been limited to the measurement of pH, EC, turbidity and bacteriological analysis. Measured pH ranges from 4.38 to 7.15 and varies in response to rainfall as shown by the examples in **Figure 8-7**. Based on the current information, the groundwater pH rises in response to rainfall, drops in response to rainfall, or shows a delayed drop in response to rainfall. It is anticipated that the groundwater pH variation is dependent on the rate of rainfall recharge across SR Area 1, as well as the location of the specific monitoring point relative to geological conditions and mining infrastructure.

According to the WHO (2007), a direct relationship between human health and the pH of drinking water is impossible to ascertain, because pH is so closely associated with other aspects of water quality, and acids and alkalis are weak and usually very dilute. However, because pH can affect the degree of corrosion of metals as well as disinfection efficiency, any effect on health is likely to be indirect and due to increased ingestion of metals from plumbing and pipes or inadequate disinfection. According to WHO (2007), it is not considered necessary to propose a health-based guideline value for pH. Any assessment regarding the suitability of water for drinking should consider the quality holistically and not just pH in isolation.

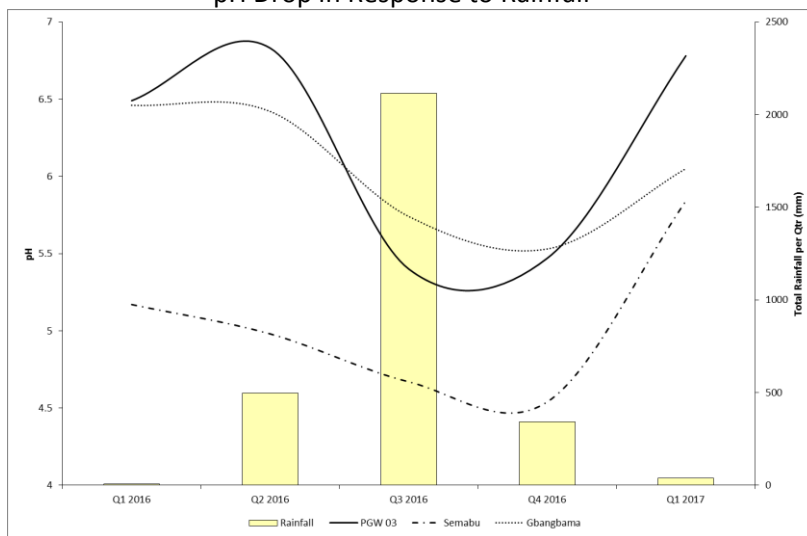
The groundwater TDS ranges from 5.56 mg/l to 77.9 mg/l which is considered to be good quality. Similarly to pH, the TDS shows a variable response to rainfall where the TDS either increases, decreases or shows a delayed response to rainfall as shown in **Figure 8-8**. It is anticipated that this variable response is due to either the dilution and/or mobilization of soluble salts. Interestingly the pH trends seem to lag behind the TDS trends at the individual monitoring points as shown in **Figure 8-9**. This suggests that pH variations may be in response to TDS fluctuations rather than vice versa.



pH Rise in Response to Rainfall

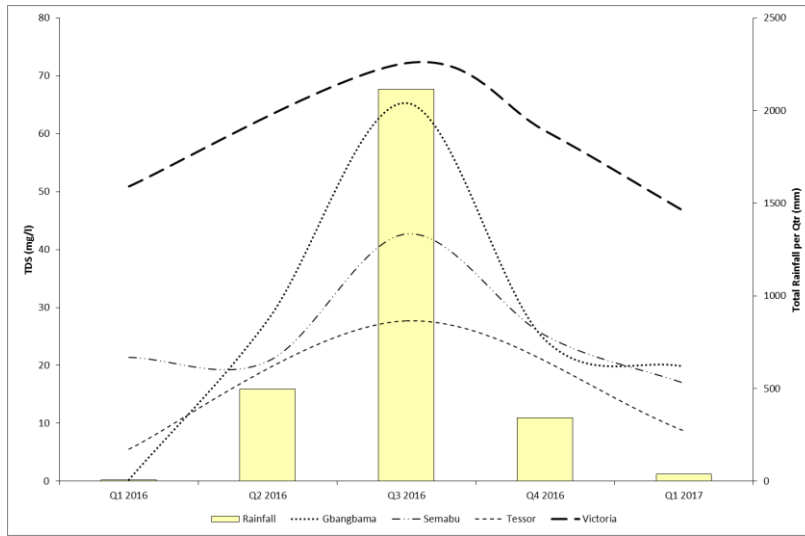


pH Drop in Response to Rainfall

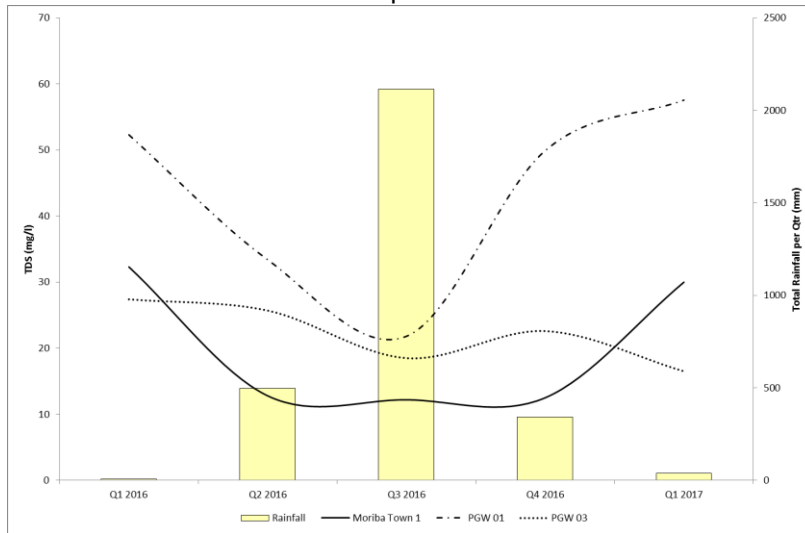


Delayed pH Response to Rainfall

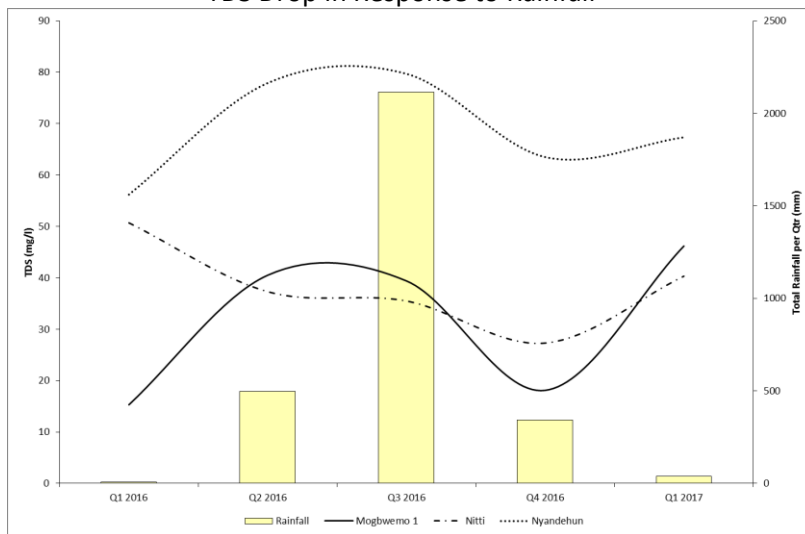
Figure 8-7: Groundwater pH Response to Rainfall



TDS Rise in Response to Rainfall

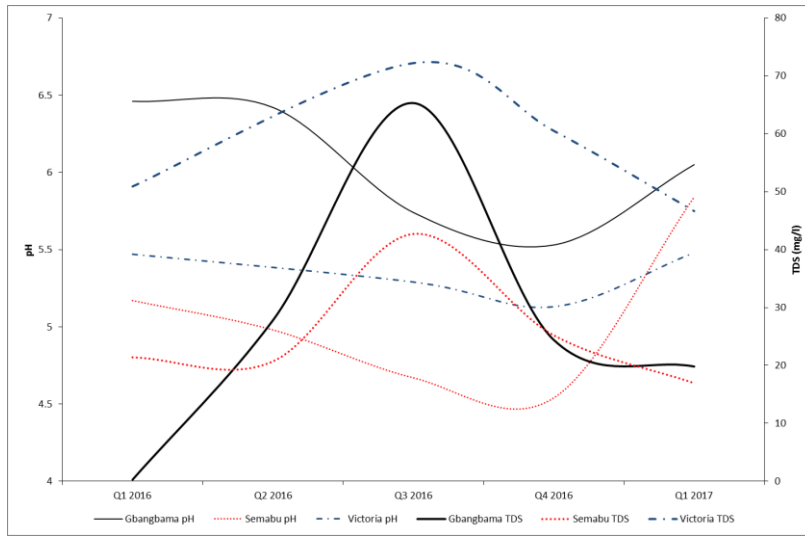


TDS Drop in Response to Rainfall

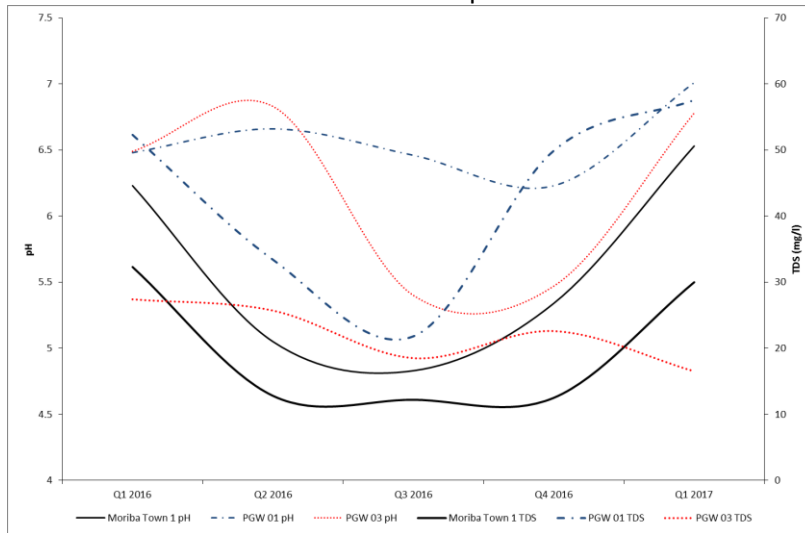


Delayed TDS Response to Rainfall

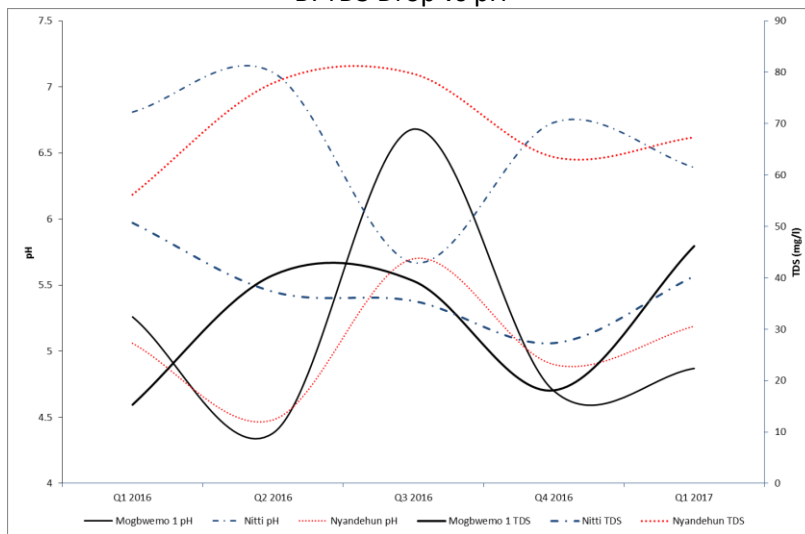
Figure 8-8: Groundwater TDS Response to Rainfall



A: TDS Rise vs pH



B: TDS Drop vs pH



C: Delayed TDS Response vs pH

Figure 8-9: Groundwater TDS Response vs pH

In Graph A in **Figure 8-9**, the rise in TDS is associated with monitoring points that are located primarily downstream or at the edges of SR Area 1. Graph B illustrates the fall in TDS associated with monitoring points that are located primarily within the high ground towards the centre of SR Area 1 while Graph C has no clear trend with respect to the monitoring locations.

The slightly to moderately acidic groundwater with the associated low TDS concentrations are attributed to the heavily leached soils which are typical in humid tropical climates. Bacteriological analyses indicate severe contamination which is attributed primarily due to human impact.

### 8.6.3 Detailed Historical Water Analyses

Detailed historical water analyses are included in SRK (2013) and Knight Piesold (2008), and are replicated in Appendix C. An extract of the effluent standard as prescribed in the Sierra Leone Environment Protection (Mines and Minerals) Regulations (2013) legislation is also included for comparison purposes. Since the latter standard has a limited list of chemical constituents, the WHO (2017) water quality drinking standards are also referenced in this evaluation.

Four samples were included in the SRK (2013) report two of which are from SRL groundwater wells, one from the Pejebu historical mining pond and one from rainwater. These samples are characterized by a slightly acidic to neutral pH with a very low EC ranging from 1.6 mS/m – 8.7 mS/m as is to be expected in this geological setting. All chemical constituents fall within the WHO (2017) drinking water and the Sierra Leone Environment Protection (Mines and Minerals) Regulations (2013) effluent standards.

Knight Piesold (2008) presents two data sets from 2001, and surface water samples from 2006. A total of seven samples, two of which are groundwater, are presented for the 2001 data. With the exception of LR-WS-07 taken from Teso Creek, all samples generally fall within the WHO (2017) drinking water and Sierra Leone Environment Protection (Mines and Minerals) Regulations (2013) effluent standards. An exception is the moderately acidic pH which ranges from 4.3 – 5.6 and aluminium ranging from 0.2 mg/l – 0.4 mg/l in three samples, two of which are groundwater. LR-WS-07 has an EC of 1 000 mS/m which is indicative of a tidal influence in this vicinity. The remainder of the samples have an EC ranging from 1.2 mS/m – 7.6 mS/m which is considered to be good quality.

The Knight Piesold (2008) 2006 data set consists of 21 samples taken from surface and process water sampling locations. The samples generally fall within the WHO (2017) drinking water and Sierra

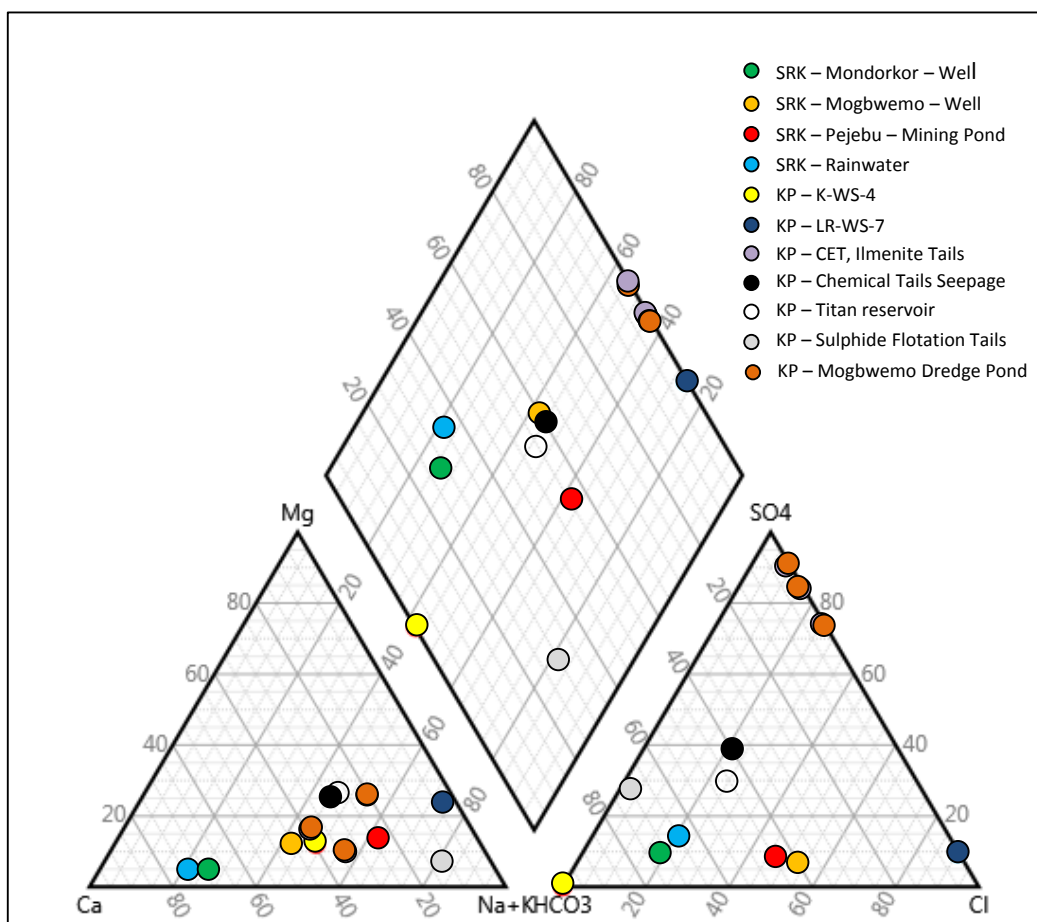


Leone Environment Protection (Mines and Minerals) Regulations (2013) effluent standards with the following exceptions:

- All samples are moderately to very acidic (pH 3.2 – 4.5) with the exception of SR-12-WQ (pH 6.2) and SR-20-WQ-B (pH 7.5);
- Aluminium is exceeded for the WHO (2017) drinking water standards within a range of 0.22 mg/l – 0.76 mg/l for thirteen samples, and
- Gross alpha and gross beta is exceeded for SR-5-WQ (TT discharge), SR-6-WQ (IT discharge), SR-7-WQ (FET) and SR-8-WQ (CET).

Knight Piesold (2008) determined that the supernatant discharge from the coarse sulphide plant tailings outlet pipe into the sulphide plant tailings holding area had radioactivity levels that exceeded the World Health Organization (WHO) guidelines (2008) for gross alpha and gross beta. Process/surface water locations downstream of the Mogbwemo dredge pond however did not exceed WHO guidelines, indicating a minimal impact from these discharge sources.

The detailed analyses were plotted on a Piper diagram as shown in **Figure 8-10**.



**Figure 8-10: SR Area 1 Piper Diagram**

It can be seen from **Figure 8-10** that the rainfall and the Mondorkor well plot towards the recent recharge area as expected. This is in contrast to the Titan reservoir, chemical tails seepage and the Mogbwemo well which are grouped together. The Pejebu historical mining pond also plots in this vicinity which suggests an improvement in water quality relative to the current tailings facilities. The CET, IT and Mogbwemo dredge pond plot between the sea water signature associated with the Teso Creek and the apex of the Piper diagram which is typically associated with mining related signatures. These samples show some mining related influence when compared to the other locations. The SFT plots towards the bottom of the Piper diagram in the sodium bicarbonate (Na-HCO<sub>3</sub>) type waters. This may be due to the additives that have been used during the flotation process.

Elevated Al is observed at a number of the sampling locations. However, this is attributed to acidic soils which form within a belt across Africa including Sierra Leone (Hede *et. al*, 2001). Under these conditions, the primary and secondary minerals dissolve to a limited extent, releasing Al into the soil solution.

Although the historical water samples have a low TDS, there is an indication that the ambient water quality has been altered by the mining and mineral beneficiation process. Localized elevated radioactivity associated with the CET and FET discharge has been measured.

## 9 SR AREA 1 MINING INFLUENCE ON GROUNDWATER

There are seven operational areas which have been evaluated in terms of the impact of mining on the groundwater regime within SR Area 1:

- Historical mining ponds;
- MSP and processed tailings facilities;
- Lanti dredge mining and tails disposal areas (wet and dry mining);
- Gbeni dry mining;
- Gangama dry mining and tails disposal;
- Nitti Port, and
- Waste disposal site.

These areas will be discussed in more detail as follows.

### 9.1 Historical Mining Ponds

The historical mining ponds were created by the construction of engineered earth impoundments across the river valleys as show in **Figure 6-2**. Although this has altered the groundwater levels, flow patterns and baseflow seepage in the immediate vicinity, it is anticipated that this will be limited to the valleys adjacent to the mining ponds. It is possible that the elevated water levels within the mining ponds have also locally raised the groundwater levels which are being accessed by the immediately adjacent community boreholes. Since the groundwater tends to mimic the topography within SR Area 1, more distant community boreholes will be unaffected.

One of the greatest risks associated with the historical mining ponds is the potential failure of the earth impoundments. These structures have sand blankets built into the wall to reduce the internal phreatic surface. Nonetheless, excessive groundwater seepage through these structures may affect the stability and is currently being monitored. The current mine closure plan includes the lowering of the water levels within all the historical mining ponds to reduce the maintenance post closure. This is also a cost-effective method of reducing the risk of wall failure. However, this remedial measure may also lower the groundwater levels within any immediately adjacent community boreholes.

The water quality in the historical mining ponds has improved over time as shown in Pejebu. However, seepage and surface water discharge from the MSP secondary processed tailings disposal area has an impact on the immediately adjacent Mogbwemo dredge pond. This trend is likely to continue for the foreseeable future unless operational changes are made to the method of tailings disposal.

The water levels within the historical mining ponds will be lowered as part of the current mine closure plan (SRK, 2018). This may expose pyrite or marcasite which may lead to further acidification. This could be significant given that the current groundwater and surface water within SR Area 1 has a low buffering capacity.

## 9.2 MSP and Tailings Facilities

There are a number of potential contaminant sources that have been previously identified within the immediate vicinity of the MSP. The majority of these are associated with the storage and use of hydrocarbons. Long term potential contaminant sources are the associated tailings disposal areas which are shown to have seepage with a lowered pH, elevated Al and radioactivity. SRK (2018) has also determined that the tailings have acid generating potential. Any impact on the groundwater quality is very localized given the close proximity of the tailings to surface water features. The significance of the groundwater regime is that it acts as a conduit for possible contaminants to migrate from the tailings facilities through the subsurface into the surface water as baseflow.

Since the MSP will be operational beyond the mining operations within SR Area 1, the current potential risk to water quality will continue unless the method of tailings disposal is significantly altered.

It is anticipated that the greatest change to groundwater levels around the MSP will be in response to the tailings disposal. However, within the context of SR Area 1, this is likely to be very localized and insignificant.

## 9.3 Lanti Wet Mining

A dredge and wet processing plant is currently operational at the Lanti mining pond and it is anticipated that this process will continue for the following 18 months. The Lanti complex is also the repository for tailings from the processing plant treating dry mined ore. Historical water quality analyses have shown that the mining pond has a lower pH and higher TDS than the historical mining

ponds (SRK, 2013). However, given that this operation is located within a broad valley, groundwater flow is expected to be towards rather than away from this area. Any potential groundwater contamination may occur through the weathered aquifer and seepage through the downstream earth impoundments. Field observations during the site visit undertaken as part of this investigation has shown that these pathways are insignificant when compared to the surface water decant.

Any changes in the groundwater elevations are anticipated to be restricted to the immediate shoreline of the Lanti mining pond and the mounding beneath the tails stacking.

Based on the historical monitoring data, the water quality in the Lanti dredge pond is likely to improve upon the cessation of mining. However, further acidification may occur if the pond level is lowered for closure thereby exposing any pyrite and marcasite to oxidising conditions.

Exposure of the tailings to oxidising conditions will occur once stacking is stopped and the induced groundwater mound beneath the tails dissipates. However, SRK (2018) has shown that the dredge spoils and dredge tailings are generally unreactive as they are composed primarily of inert minerals that are chemically resistant to weathering. The minerals are therefore considered to be non-acid generating. Nonetheless, elevated concentrations of Al, Cu, Fe, K, Mn, SO<sub>4</sub> and Zn in the leachate from the primary process tailings relative to background surface water is expected and will be included in any monitoring (SRK, 2018).

Similar to the historical mining ponds, the greatest risk of the Lanti wet mining is the potential failure of the downgradient earth impoundments. Since groundwater levels are a contributing factor to the stability of these structures, the groundwater levels are measured on a regular basis. The most cost-effective measure to reduce this risk is the lowering of the mining pond water level.

Ore is located within the vicinity of the pineapple farm immediately adjacent to the Lanti dredge pond. Monitoring borehole SRL17/14 in this area has a blow yield of 32 l/sec which suggests very high permeabilities associated with the underlying Bullom sediments. It is planned that this area will be dredged to avoid substantial water ingress during dry mining.

#### **9.4 Gbeni Dry Mining**

Mining operations at Gbeni have historically been undertaken by excavators and haulage trucks where ore has been removed at elevations above the groundwater surface. Some dewatering has been put in place to lower the groundwater by means of trenches. However, the impact of mining in

this area on the groundwater regime has been limited. During December 2017, an in-pit mining unit was constructed where the mining occurs to the base of the ore deposit within a box cut. Ore is pushed towards a hopper by dozers and loaded by excavator, from where it is pumped to a scrubber and then on to the processing plant. Tailings deposition occurs behind the box cut as the mining face progressively advances.

During the construction of the initial box cut, it was evident that most of the water ingress occurred on the eastern face on the contact between the yellow orange profile and the underlying dark grey more silty clayey sediments as shown in **Photo 9-1**. Further inspection suggests that this ingress is related to the stream in this area which is seeping through the unsaturated zone into the box cut. The pumping from the box cut will require monitoring to evaluate whether it is necessary to divert this stream further away from the box cut to reduce the water recirculation. Groundwater level measurements and pump testing results indicate that vertical seepage from the underlying weathered/fresh basement contact is also likely.



**Photo 9-1: Gbeni Dry Mine Box Cut**

Based on the current observed make up water volumes in the box cut, the greater risk will be the saturation of the box cut floor affecting production rather than the volume of groundwater ingress into the mining cut. The yellow orange sediments tend to drain relatively quickly in comparison to the underlying dark silty clayey sediments.

Rainfall ingress will have a great influence on the degree of saturation and it will be important to slope the floor of the mining cut accordingly to prevent surface water ponding as seen in **Photo 9-1**. Given the relatively low permeability of the orebody in the Gbeni deposit, it is recommended that the groundwater levels are lowered in advance of mining by means of trenches on either side of the mining cut which are linked to dewatering sumps as is presently being used.

There are two implications as the mining advances towards the west in the direction of Foinda village:

- Seepage from the river adjacent to Foinda will increase the in-pit water volumes, and
- Bullom sediments may be located beneath Foinda village with significantly higher permeabilities leading to increased water ingress.

It is important that the river be diverted away from the proximity of the planned mining operations as soon as possible. The potential extent of the Bullom sediments should also be defined so that areas of greater water ingress may be anticipated. This may have implications for the in-pit mining unit which is planned to mine the area beneath the Foinda village.

During mining the groundwater water quality is unlikely to be affected since the groundwater flow patterns will be towards the pit. However, the dewatering volume may contain suspended solids which would need to be settled prior to discharge to the receiving environment. Some assessment would also be required of the pyrite or marcasite which may still be present in the remaining submerged ore, since this may lead to acidification of water pumped from the pit.

At this stage it is presumed that the tailings will be similar to that of the Lanti wet mining in that this will consist of inert material which is unlikely to generate additional acidity. The post mining groundwater quality is therefore expected to improve to ambient conditions subject to an assessment of the potential sulphides remaining in the Gbeni deposit and the backfill plan. However, elevated concentrations of Al, Cu, Fe, K, Mn, SO<sub>4</sub> and Zn in the leachate from relative to background surface water is expected and will be included in any monitoring.

## 9.5 Gangama Dry Mining

It is Graell's understanding that the operations at Gangama will continue with excavators and haulage trucks. The mining has historically been undertaken above the groundwater surface which has had a limited impact on this regime. However, future mining operations will be deepened to the

base of the orebody below the groundwater surface. For most of the deposit the conditions are anticipated to be similar to the Gbeni operations in that:

- Saturation of the mining floor is a greater risk to production than the groundwater ingress volume;
- Some upward vertical seepage from the weathered/fresh basement contact is to be expected;
- Dewatering trenches ahead of mining is recommended to cater for the relatively low permeable orebody, and
- The surface of the mining operations should be sloped in such a manner that surface runoff is promoted rather than ponding which may promote saturated conditions.

It can be seen from **Figure 7-2** that the northern portion of the Gangama deposit may lie adjacent to the Bullom sediments. This has major implications for potential groundwater ingress especially since the base of mining extends to -5 mamsl, and the area is also immediately adjacent to the estuary in this vicinity. If the ground conditions are similar to the remainder of the ore deposit, then the groundwater ingress may be manageable. However, if the sediments in this area are Bullom strata, then this may represent a 50-fold increase in groundwater ingress into the mining operations. Alternative mining methods to dry mining may have to be considered under these circumstances. Examples include a mini dredge or alternatively a floating excavator.

Saline intrusion is likely to be a concern if the northern portion of the Gangama deposit is dry mined due to the depth of mining and the close proximity to the estuary. Any water would have to be passed through a settling pond before being discharged back into the estuary to remove any suspended solids. Monitoring of the water quality would also have to take place under these circumstances to ensure that it complied with the current legislation before being discharged.

## 9.6 Nitti Port

Nitti Port is located on the estuary on the western boundary of SR Area 1 as shown in **Figure 1-1**. This facility is used to transfer product to ships via barges. There is no evidence that the port infrastructure alters the groundwater levels in the immediate vicinity. The greatest potential contamination sources are the fuel tanks which may leak hydrocarbons into the subsurface. Given the close proximity of the estuary, the impact on groundwater would be limited before any spill entered the surface water systems.



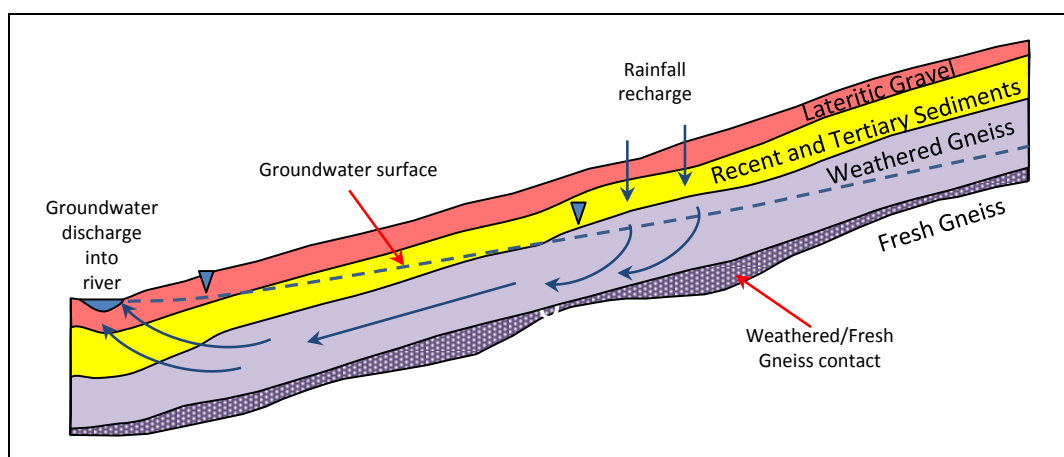
## **9.7 Waste Disposal Facility**

An ad hoc waste facility has been used for the disposal of waste at SRL. The waste has historically been disposed of in trenches which are unlined. The potential for groundwater contamination therefore exists. A new engineered landfill is currently being designed.

## 10 GROUNDWATER CONCEPTUAL MODEL

Groundwater conceptual modelling is a process whereby the field observations are documented in terms of geohydrological and hydrostratigraphic characteristics which may be translated into numerical terms during the modelling process. Previous experience and knowledge of the host lithologies are also reflected in the groundwater conceptual model especially where there is limited available field data or time dependent observations. The behaviour of the groundwater regime underlying the site is broadly described as follows.

The ambient hydrogeological conditions are illustrated in **Figure 10-1**.



**Figure 10-1: Ambient Hydrogeological Conditions**

The relatively impermeable basement is overlain by Tertiary and Recent sediments which form the ore deposit. Although the area has an extensive distribution of laterite it can be seen from **Figure 10-1** that this material predominantly lies within the unsaturated zone and as such will affect the recharge rate rather than the saturated groundwater flow patterns. Consistent water strikes of variable yields have been observed at the weathered/fractured basement contact. Two hydrostratigraphic units are therefore recommended:

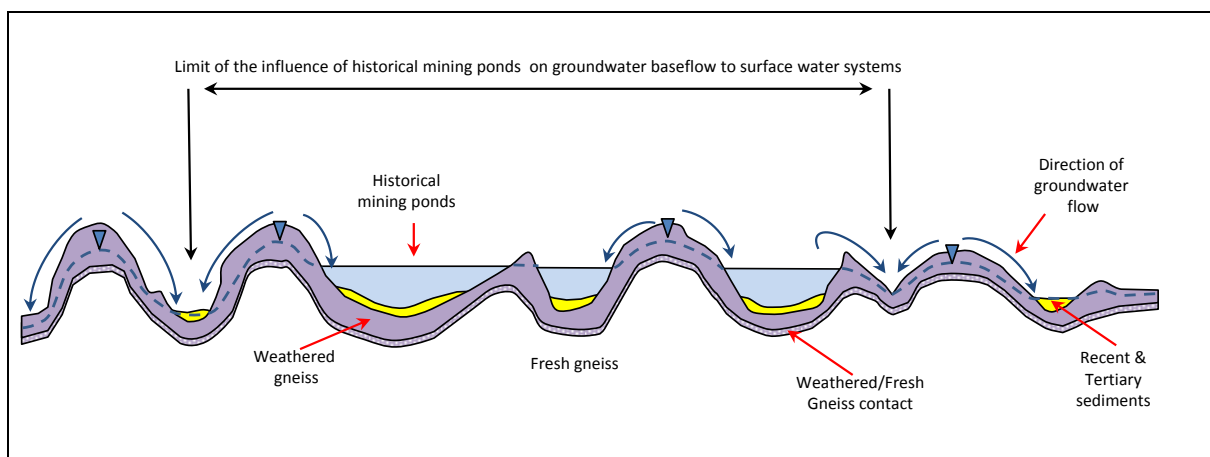
- Unconsolidated Tertiary and Recent sediments including the Bullom strata and weathered basement, and
- Weathered/fresh basement contact.

Surface water modelling by SRK (2018) indicates rainfall recharge in the order of 0.17% - 2.6% MAP. Percolating water seeps through the unsaturated zone until it intersects the regional groundwater

surface. At this stage the dominant migration pathway alters from a vertical to a lateral direction towards the nearest discharge zones where it enters the surface water systems as baseflow. This volume of water seepage is anticipated to become more important during the drier seasons in the absence of reliable rainfall. The groundwater gradients predominantly mimic the topography as would be expected for this geological setting.

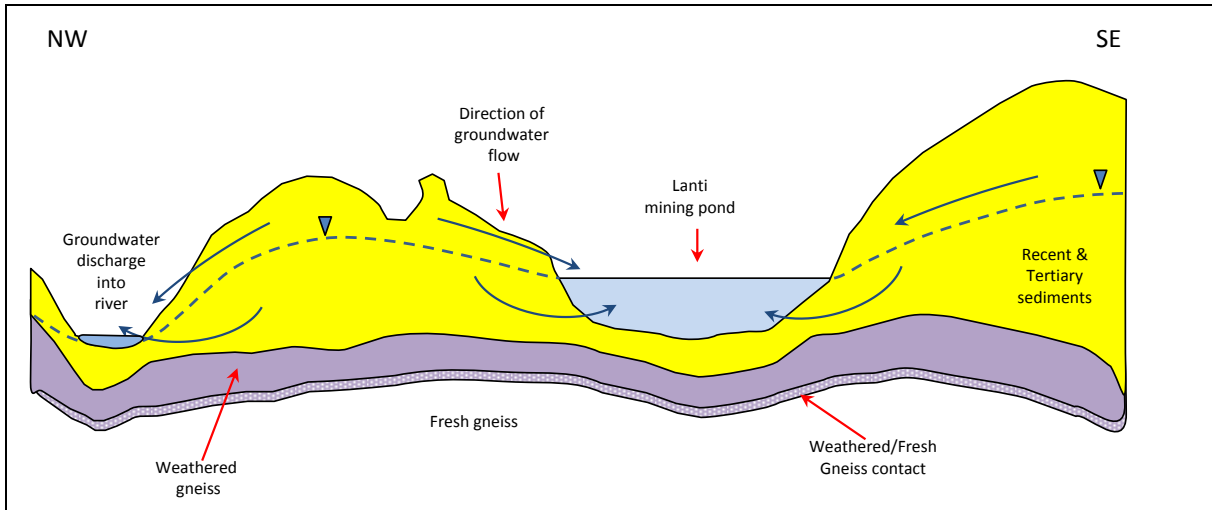
The poorly sorted unconsolidated sediments and weathered bedrock tend to have a low transmissivity ( $0.12 \text{ m}^2/\text{day} - 6 \text{ m}^2/\text{day}$ ). In contrast the weathered/fractured basement contact has a wider transmissivity range ( $6 \text{ m}^2/\text{day} - 200 \text{ m}^2/\text{day}$ ) depending on the nature of the contact at a specific location. Based on the observed blow yields, the Bullom strata on the western boundary of SR Area 1 has the highest transmissivity estimated to be in the order of  $300 \text{ m}^2/\text{day}$ .

The groundwater gradients and baseflow in the vicinity of the historical mining ponds have already adjusted to these features and any impact on the environment has therefore already occurred (**See Figure 10-2**). It can be seen that the impact on baseflow is restricted to the river valleys immediately adjacent to the historical mining ponds.



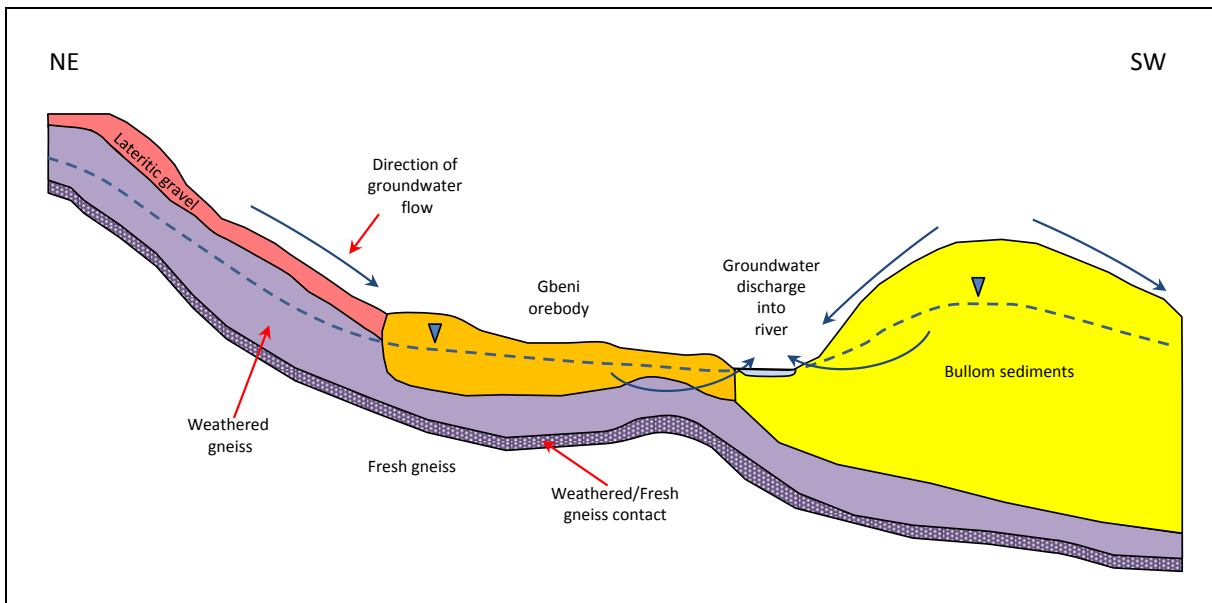
**Figure 10-2: Historical Mining Pond Groundwater Flow Patterns**

Similar to the historical mining ponds, the groundwater gradients have also adjusted in response to the Lanti dredge pond as shown in **Figure 10-3**. It is important to note that the groundwater flow occurs predominantly towards the Lanti dredge pond rather than away from it. However, some groundwater seepage does occur from the mining pond through the weathered aquifer in the vicinity of the downgradient earth impoundments.

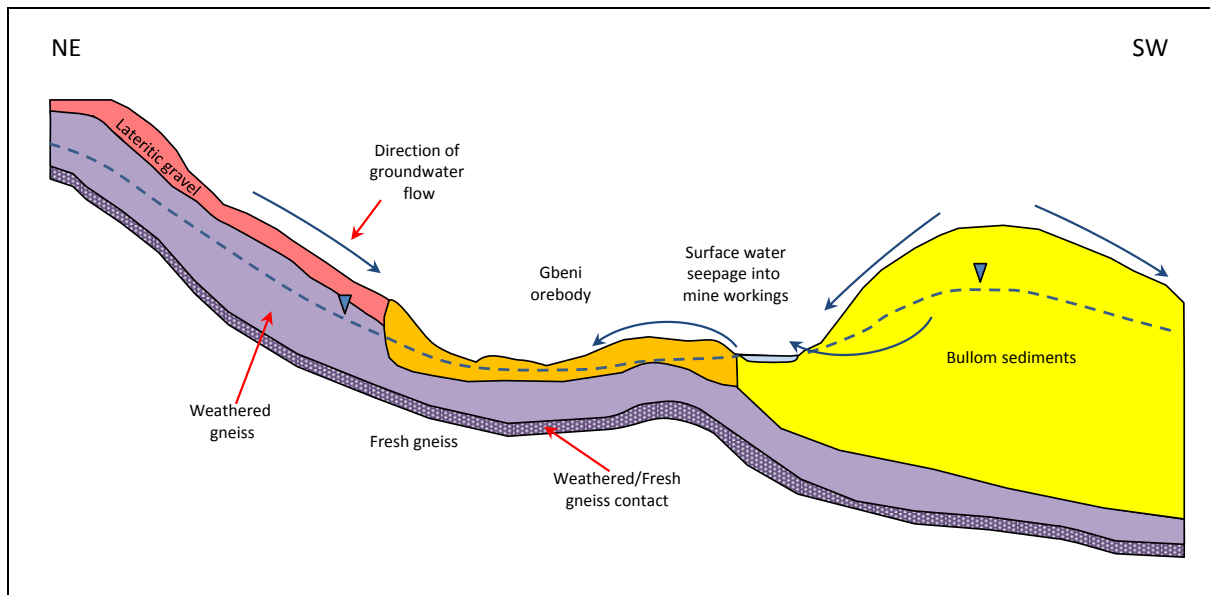


**Figure 10-3: Lanti Mining Pond Groundwater Flow Patterns**

Groundwater gradients around the Gbeni and Gangama dry mining operations will steepen as the base of the orebody is accessed below the groundwater surface (See **Figure 10-4** and **Figure 10-5** ). Some vertical leakage from the underlying weathered/fractured basement contact will also occur. Given the low permeability of the ore deposit, the groundwater ingress volumes should be manageable, and dewatering may be achieved through the use of trenches which are connected to sumps at the lowest elevation. However, sudden ingress may occur if highly permeable sands and gravels are intersected.



**Figure 10-4: Gbeni Pre-Mining Groundwater Flow Patterns**



**Figure 10-5: Gbeni Groundwater Flow Patterns During Mining**

Substantially higher groundwater ingress volumes are anticipated should the mining operations encounter Bullom sediments as shown in **Figure 7-2** such as at Foinda village at Gbeni and in the northern extent of the Gangama deposit. Alternative mining methods may have to be considered under these circumstances.

Ore is located within the vicinity of the pineapple farm immediately adjacent to the Lanti dredge pond. Monitoring borehole SRL17/14 in this area has a blow yield of 32 l/sec which suggests very high permeabilities associated with the underlying Bullom sediments. It is planned that this area will be dredged to avoid substantial water ingress during dry mining.

Upon mine closure, the groundwater gradients are expected to recover to their ambient levels especially if the post mining topography reflects the pre-mining conditions and diverted rivers are reinstated. The lowering of the historical mining pond levels will assist in this regard.

The ambient groundwater within SR Area 1 is slightly to moderately acidic with a very low TDS which is characteristic of heavily leached soils in the humid tropics (Knight Piesold, 2008). SRL monitoring of the community boreholes has indicated extensive bacteriological contamination which has been attributed to human impacts.

Changes to groundwater quality due to the SRL operations are greatest around the secondary processed tailings disposal area at the MSP. This area will have to be rehabilitated on an ongoing basis to reduce the impact on post mining water quality. The remainder of the mining activities within the SR Area 1 has a limited impact on groundwater quality since the tailings tend to be inert with no significant addition to acidification. An exception is the current Lanti dredge pond, however this water quality is expected to improve upon the cessation of mining. Nonetheless, elevated concentrations of Al, Cu, Fe, K, Mn, SO<sub>4</sub> and Zn in the leachate from the primary process tailings relative to background surface water are expected and will be monitored.

If the historical and Lanti mining pond water levels are lowered, then there may be a period of greater acidity and salt loading if additional pyrite or marcasite is exposed as a result.

Saline intrusion will be a factor if dry mining is undertaken in close proximity to the estuary in the northern extremity of the Gangama deposit. Any intercepted saline water should be discharged back into the estuary after passing through settling ponds if the water is of an acceptable quality. If the saline water ingress is too high, then alternative mining methods may need to be considered.

## 11 IMPACT ASSESSMENT

### 11.1 Impact Assessment Methodology

The impact assessment has been undertaken based on the methodology provided by SRK for the ESHIA. The following guidelines have been provided.

The impact assessment is generally divided into three parts:

- Issue identification - each specialist will be required to evaluate the ‘aspects’ arising from the project description and ensure that all issues in their area of expertise have been identified;
- Impact definition - positive and negative impacts associated with these issues (and any others not included) will then be defined. The definition statement will include the activity (source of impact), aspect and receptor as well as whether the impact is direct, indirect or cumulative. Fatal flaws should also be identified at this stage, and
- Impact evaluation – this is not a purely objective and quantitative exercise. It has a subjective element, often using judgement and values as much as science-based criteria and standards. The need therefore exists to clearly explain how impacts have been interpreted so that others can see the weight attached to different factors and can understand the rationale of the assessment.

The impact assessment significance rating that has been used during this process is shown in **Table 11-1**. The assessment considers the significance rating before and after the implementation of management measures. As per the guidelines from SRK:

*“Recommendations for management should focus on avoidance, and if avoidance is not possible, then to reduce, restore, compensate/offset negative impacts, enhance positive impacts and assist project design.”*

The significance of impacts will be re-assessed with assumed management measures in place (“after management”).

Table 11-1: Impact Assessment Significance Rating

PART A: DEFINING CONSEQUENCE IN TERMS OF MAGNITUDE, DURATION AND SPATIAL SCALE					
<i>Use these definitions to define the consequence in Part B</i>					
Impact characteristics	Definition	Criteria			
<b>MAGNITUDE</b>	Major	Substantial deterioration or harm to receptors; receiving environment has an inherent value to stakeholders; receptors of impact are of conservation importance; or identified threshold often exceeded			
	Moderate	Moderate/measurable deterioration or harm to receptors; receiving environment moderately sensitive; or identified threshold occasionally exceeded			
	Minor	Minor deterioration (nuisance or minor deterioration) or harm to receptors; change to receiving environment not measurable; or identified threshold never exceeded			
	Minor+	Minor improvement; change not measurable; or threshold never exceeded			
	Moderate+	Moderate improvement; within or better than the threshold; or no observed reaction			
	Major+	Substantial improvement; within or better than the threshold; or favourable publicity			
<b>SPATIAL SCALE OR POPULATION</b>	Site or local	Site specific or confined to the immediate project area			
	Regional	May be defined in various ways, e.g. cadastral, catchment, topographic			
	National/ International	Nationally or beyond			
<b>DURATION</b>	Short term	Up to 12 months.			
	Medium term	12 months to 5 years			
	Long term	Longer than 5 years			
PART B: DETERMINING CONSEQUENCE RATING					
<i>Rate consequence based on definition of magnitude, spatial extent and duration</i>					
		SPATIAL SCALE/ POPULATION			
		Site or Local	Regional	National/ international	
MAGNITUDE					
Minor	DURATION	Long term	Medium	Medium	High
		Medium term	Low	Low	Medium
		Short term	Low	Low	Medium
Moderate	DURATION	Long term	Medium	High	High
		Medium term	Medium	Medium	High
		Short term	Low	Medium	Medium



Major	DURATION	Long term	High	High	High
		Medium term	Medium	Medium	High
		Short term	Medium	Medium	High
<b>PART C: DETERMINING SIGNIFICANCE RATING</b> <i>Rate significance based on consequence and probability</i>					
		<b>CONSEQUENCE</b>			
		Low	Medium	High	
PROBABILITY (of exposure to impacts)	Definite		Medium	Medium	High
	Possible		Low	Medium	High
	Unlikely		Low	Low	Medium
<b>PART D: CONFIDENCE LEVEL</b>					
High		Medium		Low	

Each potential hydrogeological impact (whether positive or negative) associated with mining activities in SR Area 1 has been outlined below and rated in terms of its significance using the SRK impact rating methodology. The degree of confidence of each assessment is also stated.

## 11.2 Direct Impacts

The SRL mining activities that may potentially directly impact the groundwater regime within SR Area 1 are as follows:

- Historical mining ponds during the operational and decommissioning phase;
- MSP during the operational and decommissioning phase;
- Lanti wet mining during the operational and decommissioning phase;
- Gbeni dry mining during the operational and decommissioning phase;
- Gangama dry mining during the operational and decommissioning phase;
- Nitti Port during the operational and decommissioning phase, and
- Landfill site during the operational and decommissioning phase.

The impact of these activities on the groundwater quantity and quality are discussed below:

### 11.2.1 Impact 1a – Elevated Historical Mining Pond Levels May Increase the Available Drawdown in Community Boreholes (Operational Phase)

#### 11.2.1.1 Description

The historical mining ponds have been created by the construction of engineered earth impoundments across the river valleys. This has resulted in a raised pond water level surface. Groundwater levels within the adjacent valleys to the historical mining ponds may have been raised as a result. Community boreholes would have a greater available drawdown which would allow more abstraction before the borehole needed to recover.

#### 11.2.1.2 Proposed Mitigation Measures

Since this is a positive impact, no mitigations measures are proposed.

#### 11.2.1.3 Impact Assessment

The magnitude of the impact of increasing the available drawdown within the community boreholes is considered to be “minor” when compared to the overall borehole yield. Since the historical mining ponds may remain in place for longer than five years, the duration is considered to be “long term”. Only those community boreholes in the immediate vicinity are likely to be affected hence the spatial scale is considered to be “site specific” or “local”. The consequence of this impact is therefore rated as “medium”. As there are no community borehole water level records prior to the construction of the historical ponds, the increased available drawdown is considered to be “possible”. The significance of the impact is “medium” and “positive” while the confidence of the assessment is “medium”. The result of the impact assessment is summarised in **Table 11-2**.

**Table 11-2: Impact 1a – Impact Assessment Summary**

<b>Impact 1a: Raised Historical Mining Pond Levels Increasing Available Drawdown in Community Boreholes</b>								
	<b>Magnitude</b>	<b>Duration</b>	<b>Scale</b>	<b>Consequence</b>	<b>Probability</b>	<b>Significance</b>	<b>+ /-</b>	<b>Confidence</b>
<b>Before Management</b>	<i>Minor</i>	<i>Long term</i>	<i>Site / local</i>	<i>Medium</i>	<i>Possible</i>	<b>Medium</b>	<i>+</i>	<i>Medium</i>
<b>Management Measures:</b>								
<ul style="list-style-type: none"> <li>None proposed.</li> </ul>								
<b>After Management</b>	<i>Minor</i>	<i>Long term</i>	<i>Site / local</i>	<i>Medium</i>	<i>Possible</i>	<b>Medium</b>	<i>+</i>	<i>Medium</i>

#### 11.2.1.4 Proposed Monitoring or Action Plans

An updated hydrocensus should be undertaken by SRL to confirm the location of all groundwater extraction points within SR Area 1. It is recommended that the yield of the community boreholes is monitored on a monthly basis to record the current performance. Groundwater levels within the boreholes should also be recorded where possible. Where this is not feasible, the SRL groundwater monitoring network should be used to record the response of the groundwater regime to the raised water levels within the historical mining ponds.

#### 11.2.2 Impact 1b – Lowered Historical Mining Pond Levels May Reduce the Available Drawdown in Community Boreholes (Decommissioning Phase)

##### 11.2.2.1 Description

In the current mine closure plan the water levels within the historical mining ponds will be lowered to reduce maintenance and the risk of dam wall failure. This may cause the groundwater levels in the community boreholes in the immediate vicinity to fluctuate and/or drop to the point where they can no longer function.

##### 11.2.2.2 Proposed Mitigation Measures

Communities who have their boreholes impacted by the lowering of the historical mining pond water levels will have to be provided with an alternative water supply.

##### 11.2.2.3 Impact Assessment

The magnitude of the impact of the community boreholes in the immediate vicinity no longer functioning is considered to be “moderate”. It is assumed that any reduction in the historical mining pond water levels is a permanent management measure and the duration is therefore considered to be “long term”. Only those community boreholes in the immediate vicinity are likely to be affected hence the spatial scale is considered to be “site specific” or “local”. The consequence of this impact is therefore rated as “medium”. As there are no community borehole water level records prior to the construction of the historical ponds, the impact is considered to be “possible”. The significance of the impact is “medium” and “negative” while the confidence of the assessment is “medium”. After the implementation of the management measures, the magnitude of the impact is reduced to “minor” while the probability of exposure decreases to “unlikely”. The consequence of the impact is

reduced to “low” while the confidence in the assessment of the management measures is “high”. The result of the impact assessment is summarised in **Table 11-3**.

**Table 11-3: Impact 1b - Impact Assessment Summary**

<b>Impact 1b: Lowered Historical Mining Pond Levels May Reduce Available Drawdown in Community Boreholes</b>								
	Magnitude	Duration	Scale	Consequence	Probability	Significance	+ /-	Confidence
<b>Before Management</b>	<i>Moderate</i>	<i>Long term</i>	<i>Site / local</i>	<b>Medium</b>	<i>Possible</i>	<b>Medium</b>	-	<i>Medium</i>
<b>Management Measures:</b>								
<ul style="list-style-type: none"> <li>Provide alternative water supply if community boreholes in the immediate vicinity no longer function.</li> </ul>								
<b>After Management</b>	<i>Minor</i>	<i>Long term</i>	<i>Site / local</i>	<b>Medium</b>	<i>Unlikely</i>	<b>Low</b>	-	<i>High</i>

#### 11.2.2.4 Proposed Monitoring or Action Plans

Similar to Impact 1a, an updated hydrocensus should be undertaken by SRL to confirm the location of all groundwater extraction points within SR Area 1. It is recommended that the yield of the community boreholes is monitored on a monthly basis to record the current performance. Groundwater levels within the boreholes should also be recorded where possible. Where this is not feasible, the SRL groundwater monitoring network should be used to record the response of the groundwater regime to any lowering of the water levels within the historical mining ponds.

#### 11.2.3 Impact 1c – Lowered Historical Mining Pond Levels May Expose Sulphides Leading to Groundwater Acidification (Decommissioning Phase)

##### 11.2.3.1 Description

As discussed previously, in the current mine closure plan the water levels within the historical mining ponds will be lowered for maintenance and to reduce the risk of dam wall failure. This may in turn expose previously inundated sulphides which may lead to acidification and contamination of the groundwater regime in the immediate vicinity.

### 11.2.3.2 Proposed Mitigation Measures

The potentially acid generating material should be identified through sampling and either be rehabilitated to reduce the rate of acidification, or be disposed of sub aqueously beneath a permanent water level elevation.

### 11.2.3.3 Impact Assessment

The magnitude of the impact of the exposure of sulphides during the lowering of the historical mining pond water levels and subsequent contamination of groundwater is considered to be “moderate”. It is assumed that any reduction in the historical mining pond water levels is a permanent management measure and the duration is therefore considered to be “long term”. Only groundwater in the immediate vicinity is likely to be affected hence the spatial scale is considered to be “site specific” or “local”. The consequence of this impact is therefore rated as “medium”. It is uncertain whether sulphides exist at the base of the historical mining ponds and the impact is therefore considered to be “possible”. The significance of the impact is “medium” and “negative” while the confidence of the assessment is “low”.

After the implementation of the management measures, the magnitude of the impact is reduced to “minor” while the probability of exposure to this impact remains at “possible”. The confidence in the assessment of the management measures is “medium”. The result of the impact assessment is summarised in **Table 11-4**.

**Table 11-4: Impact 1c - Impact Assessment Summary**

<b>Impact 1c: Lowered Historical Mining Pond Levels May Expose Sulphides Leading to Groundwater Acidification</b>								
	<b>Magnitude</b>	<b>Duration</b>	<b>Scale</b>	<b>Consequence</b>	<b>Probability</b>	<b>Significance</b>	<b>+ /-</b>	<b>Confidence</b>
<b>Before Management</b>	<i>Moderate</i>	<i>Long term</i>	<i>Site / local</i>	<i>Medium</i>	<i>Possible</i>	<b>Medium</b>	-	<i>Low</i>
<b>Management Measures:</b>								
<ul style="list-style-type: none"> <li>Sample for sulphides and rehabilitate potentially acid generating material or dispose of sub aqueously beneath a permanent water level elevation.</li> </ul>								
<b>After Management</b>	<i>Minor</i>	<i>Long term</i>	<i>Site / local</i>	<i>Medium</i>	<i>Possible</i>	<b>Medium</b>	-	<i>Medium</i>

#### 11.2.3.4 Proposed Monitoring or Action Plans

A sampling program should be undertaken to determine the nature of the sediment at the base of the historical mining ponds. The groundwater quality in the boreholes in the immediate vicinity should be monitored so that any trends may be recorded to confirm or disprove any impact of the lowering of the historical mining pond levels on the groundwater quality.

#### 11.2.4 Impact 2a – Seepage from MSP Tailings and Dams Raising Groundwater Levels (Operational Phase)

##### 11.2.4.1 Description

The MSP has a number of processed tailings which are deposited at the edge of the Mogbwemo dredge pond. Any water used during the deposition of these tailings will contribute to additional seepage from recharge over the unrehabilitated area. This additional seepage is likely to result in raised groundwater levels within the immediate vicinity.

##### 11.2.4.2 Proposed Mitigation Measures

Since the raised groundwater levels are localized and in close proximity to the Mogbwemo dredge pond, no mitigation measures are proposed.

##### 11.2.4.3 Impact Assessment

The magnitude of the impact of the raised groundwater levels in response to additional seepage from the processed tailings and MSP dams is considered to be “minor”. Since the MSP will be operational for longer than five years the duration is considered to be “long term”. Only groundwater in the immediate vicinity is likely to be affected hence the spatial scale is considered to be “site specific” or “local”. The consequence of this impact is therefore rated as “medium”. Given the unrehabilitated nature of the tailings and the method of disposal the probability of this impact is considered to be “definite”. The significance of the impact is “medium” and “negative” while the confidence of the assessment is “high”. The result of the impact assessment is summarised in **Table 11-5**.

Table 11-5: Impact 2a - Impact Assessment Summary

Impact 2a: Seepage from MSP Tailings and Dams Raising Groundwater Levels								
	Magnitude	Duration	Scale	Consequence	Probability	Significance	+ /-	Confidence
Before Management	Minor	Long term	Site / local	Medium	Definite	Medium	-	High
Management Measures:								
<ul style="list-style-type: none"> <li>No management measures are proposed.</li> </ul>								
After Management	Minor	Long term	Site / local	Medium	Definite	Medium	-	High

#### 11.2.4.4 Proposed Monitoring or Action Plans

No monitoring or action plans are proposed to address the raised groundwater levels beneath the processing tailings disposal area.

#### 11.2.5 Impact 2b – Decommissioning the MSP Tailings and Dams Will Lower Groundwater Levels Beneath the Tailings Disposal Area (Decommissioning Phase)

##### 11.2.5.1 Description

After the MSP secondary processed tailings disposal area is decommissioned, the seepage to groundwater will reduce particularly if the area is properly rehabilitated. Groundwater gradients are expected to return to ambient conditions especially if the water level in the Mogbwemo pond is lowered as part of the mine closure plan.

##### 11.2.5.2 Proposed Mitigation Measures

The MSP tailings area should be rehabilitated to minimize seepage through the tailings material.

##### 11.2.5.3 Impact Assessment

The magnitude of the lowered groundwater levels in response to the decommissioning and rehabilitation of the MSP tailings area is considered to be “minor”. Since the decommissioning of the MSP is considered to be permanent the duration is considered to be “long term”. Only groundwater in the immediate vicinity is likely to be affected hence the spatial scale is considered to be “site specific” or “local”. The consequence of this impact is therefore rated as “medium”. Prior to the implementation of management measures the probability of this impact is considered to be

“possible”. The significance of the impact is “medium” and “positive” while the confidence of the assessment is “medium”. Assuming the rehabilitation of the MSP tailings area is appropriate, the probability of exposure to this impact is raised to “definite”. The post management significance of the impact remains “medium” and “positive” although the confidence of the assessment is “high”. The result of the impact assessment is summarised in **Table 11-6**.

**Table 11-6: Impact 2b - Impact Assessment Summary**

<b>Impact 2b: Decommissioning the MSP Tailings and Dams Will Lower Groundwater Levels Beneath the Tailings Disposal Area</b>								
	Magnitude	Duration	Scale	Consequence	Probability	Significance	+ /-	Confidence
<b>Before Management</b>	<i>Minor</i>	<i>Long term</i>	<i>Site / local</i>	<b>Medium</b>	<b>Possible</b>	<b>Medium</b>	+	<i>Medium</i>
<b>Management Measures:</b>								
<ul style="list-style-type: none"> <li>• Appropriate rehabilitation of the processed tailings area.</li> </ul>								
<b>After Management</b>	<i>Minor</i>	<i>Long term</i>	<i>Site / local</i>	<b>Medium</b>	<b>Definite</b>	<b>Medium</b>	+	<i>High</i>

#### 11.2.5.4 Proposed Monitoring or Action Plans

No additional monitoring or action plans are proposed to address this impact.

#### 11.2.6 Impact 2c – MSP Hydrocarbon and Sewage Spills Contaminating Groundwater (Operational Phase)

##### 11.2.6.1 Description

While the MSP is operational, there is a risk of hydrocarbon or sewage spills which may contaminate the groundwater in the immediate vicinity.

##### 11.2.6.2 Proposed Mitigation Measures

The following mitigation measures are recommended:

- Proper maintenance of all vehicles and machinery to prevent fuel or oil leaks and spillages;
- Vehicles and machinery should be serviced in bunded areas with drip trays;



- A hydrocarbon absorbing product should be kept on site and used to clean up hydrocarbon spills in the event that they should occur, and
- The sewage treatment process should be properly maintained to ensure that it is operating within design specification.

### 11.2.6.3 Impact Assessment

Since it is assumed that any incident will be quickly identified, the magnitude of any hydrocarbon or sewage spill is considered to be “minor” and the duration “short term”. Only groundwater in the immediate vicinity is likely to be affected hence the spatial scale is considered to be “site specific” or “local”. The consequence of this impact is therefore rated as “low”. The probability of the exposure to this impact is considered to be “possible”. The significance of this impact is considered to be “low” and “negative” with the confidence in the assessment rated as “high”. With the implementation of the management measures the only change to the impact assessment is that the probability of exposure reduces from “possible” to “unlikely”. The significance of the impact remains “low” and “negative” while the confidence of the assessment remains “high”. The result of the impact assessment is summarised in **Table 11-7**.

**Table 11-7: Impact 2c - Impact Assessment Summary**

<b>Impact 2c – MSP Hydrocarbon and Sewage Spills Contaminating Groundwater</b>								
	<b>Magnitude</b>	<b>Duration</b>	<b>Scale</b>	<b>Consequence</b>	<b>Probability</b>	<b>Significance</b>	<b>+ / -</b>	<b>Confidence</b>
<b>Before Management</b>	<i>Minor</i>	<i>Short term</i>	<i>Site / local</i>	<b>Low</b>	<b>Possible</b>	<b>Low</b>	-	<i>High</i>
<b>Management Measures:</b>								
<ul style="list-style-type: none"> <li>• Proper maintenance of all vehicles and machinery to prevent fuel or oil leaks and spillages;</li> <li>• Vehicles and machinery should be serviced in bunded areas with drip trays;</li> <li>• A hydrocarbon absorbing product should be kept on site and used to clean up hydrocarbon spills in the event that they should occur, and</li> <li>• The sewage treatment process should be properly maintained to ensure that it is operating within design specification.</li> </ul>								
<b>After Management</b>	<i>Minor</i>	<i>Short term</i>	<i>Site / local</i>	<b>Low</b>	<b>Unlikely</b>	<b>Low</b>	-	<i>High</i>

#### 11.2.6.4 Proposed Monitoring or Action Plans

Standard operating procedures regarding the maintenance and refuelling of equipment onsite should be audited on a regular basis. The discharge from the sewage treatment should be monitored to ensure that the plant is operating within the design limitations. Monitoring piezometers should be installed downgradient from the potential contaminant sources so that groundwater samples may be taken on a quarterly basis.

#### 11.2.7 Impact 2d – MSP Secondary Processed Tails Acid Generation Contaminating Groundwater (Operational and Decommissioning Phase)

##### 11.2.7.1 Description

SRK (2018) has determined that the MSP secondary processed tailings are acid generating. Historical sampling by Knight Piesold (2008) has shown that the tailings are also associated with elevated Al and radioactivity. This hydrochemistry may lead to the contamination of groundwater in the immediate vicinity. The potential impact on groundwater during the operational and decommissioning phase is similar and both phases will therefore be addressed in this impact assessment. The significance of the groundwater contamination is that it acts as a pathway between the processed tailings and the nearby Mogbwemo dredge pond.

##### 11.2.7.2 Proposed Mitigation Measures

It is recommended that the acid generating material be identified and either disposed of subaqueously or be placed within a designated area which may be appropriately rehabilitated to minimize infiltration and hence acidification. Any potentially radioactive material should also be identified and appropriately isolated from the receiving environment.

##### 11.2.7.3 Impact Assessment

Given the potential for acidification etc., the magnitude of this impact is considered to be “moderate”. Since the tailings are likely to remain in place permanently, the duration is considered to be “long term”. Only groundwater in the immediate vicinity is likely to be affected hence the spatial scale is considered to be “site specific” or “local”. The consequence of this impact is therefore rated as “medium”. The probability of the exposure to this impact is considered to be “definite”

since it is already occurring. The significance of this impact is considered to be “medium” and “negative” with the confidence in the assessment rated as “high”.

With the implementation of the management measures the magnitude of the impact is considered to be reduced to “minor” while the duration remains “long term”. The spatial scale remains “site specific” or “local”. The consequence of the impact remains “medium” while the probability of exposure reduces from “definite” to “possible”. The significance of the impact remains “medium” and “negative” while the confidence of the assessment remains “high”. The result of the impact assessment is summarised in **Table 11-8**.

**Table 11-8: Impact 2d - Impact Assessment Summary**

<b>Impact 2d – MSP Secondary Processed Tails Acid Generation Contaminating Groundwater</b>								
	<b>Magnitude</b>	<b>Duration</b>	<b>Scale</b>	<b>Consequence</b>	<b>Probability</b>	<b>Significance</b>	<b>+ /-</b>	<b>Confidence</b>
<b>Before Management</b>	<i>Moderate</i>	<i>Long term</i>	<i>Site / local</i>	<b>Medium</b>	<b>Definite</b>	<b>Medium</b>	-	<i>High</i>
<b>Management Measures:</b>								
<ul style="list-style-type: none"> <li>• Acid generating material is identified and either disposed of sub aqueously or isolated from the receiving environment through appropriate rehabilitation measures; and</li> <li>• Radioactive material should be identified and isolated from the receiving environment through appropriate rehabilitation measures.</li> </ul>								
<b>After Management</b>	<i>Minor</i>	<i>Long term</i>	<i>Site / local</i>	<b>Medium</b>	<b>Possible</b>	<b>Medium</b>	-	<i>High</i>

#### 11.2.7.4 Proposed Monitoring or Action Plans

Shallow piezometers should be installed to monitor the groundwater quality downgradient from the MSP secondary processed tailings storage area. These results may then be compared to the post rehabilitation groundwater quality to evaluate the efficacy of the management measures.

#### 11.2.8 Impact 3a – Elevated Lanti Mining Pond Levels May Increase the Available Drawdown in Community Boreholes (Operational Phase)

##### 11.2.8.1 Description

The Lanti mining pond has also been created by the construction of engineered earth impoundments across the river valley. This has resulted in a raised pond water level surface. However, it is

anticipated that the groundwater levels will only be raised in close proximity to the pond edge since the groundwater gradients will still mimic the topography in the remainder of the broad valley. Community boreholes would have a greater available drawdown which would allow more abstraction before the borehole needed to recover.

#### 11.2.8.2 Proposed Mitigation Measures

Since this is a positive impact, no mitigations measures are proposed.

#### 11.2.8.3 Impact Assessment

The magnitude of the impact of increasing the available drawdown within the community boreholes is “minor” when compared to the overall borehole yield. Since the Lanti dredge pond will still be operation for approximately 18 months, the duration is considered to be “medium term”. Only those community boreholes in the immediate vicinity of the mining pond edge are likely to be affected hence the spatial scale is considered to be “site specific” or “local”. The consequence of this impact is therefore rated as “low”. As there are no community borehole water level records prior to the construction of the Lanti dredge pond, the increased available drawdown is considered to be “possible”. The significance of the impact is “low” and “positive” while the confidence of the assessment is “medium”. The result of the impact assessment is summarised in **Table 11-9**.

**Table 11-9: Impact 3a - Impact Assessment Summary**

<b>Impact 3a: Raised Lanti Mining Pond Level Increasing Available Drawdown in Community Boreholes</b>								
	<b>Magnitude</b>	<b>Duration</b>	<b>Scale</b>	<b>Consequence</b>	<b>Probability</b>	<b>Significance</b>	<b>+ /-</b>	<b>Confidence</b>
<b>Before Management</b>	<i>Minor</i>	<i>Medium term</i>	<i>Site / local</i>	<b>Low</b>	<b>Possible</b>	<b>Low</b>	+	<i>Medium</i>
<b>Management Measures:</b>								
<ul style="list-style-type: none"> <li>None proposed</li> </ul>								
<b>After Management</b>	<i>Minor</i>	<i>Medium term</i>	<i>Site / local</i>	<b>Low</b>	<b>Possible</b>	<b>Low</b>	+	<i>Medium</i>

#### 11.2.8.4 Proposed Monitoring or Action Plans

An updated hydrocensus should be undertaken by SRL to confirm the location of all groundwater extraction points within SR Area 1. It is recommended that the yield of the community boreholes in

the immediate vicinity is monitored on a monthly basis to record the current performance. Groundwater levels within the boreholes should also be recorded where possible. Where this is not feasible, the SRL groundwater monitoring network should be used to record the response of the groundwater regime to the raised water level within the Lanti mining pond.

### 11.2.9 Impact 3b – Lowered Lanti Mining Pond Levels May Reduce the Available Drawdown in Community Boreholes (Decommissioning Phase)

#### 11.2.9.1 *Description*

In the current mine plan, the water level within the Lanti mining pond will be lowered to reduce the maintenance and risk of dam wall failure. This may cause the groundwater levels in the community boreholes in the immediate vicinity of the pond edge to fluctuate and/or drop to the point where they can no longer function.

#### 11.2.9.2 *Proposed Mitigation Measures*

Communities who have their boreholes impacted by the lowering of the Lanti mining pond water levels will have to be provided with an alternative water supply.

#### 11.2.9.3 *Impact Assessment*

The magnitude of the impact of the community boreholes in the immediate vicinity of the Lanti mining pond no longer functioning is considered to be “moderate”. It is assumed that any reduction in the Lanti mining pond water levels is a permanent management measure and the duration is therefore considered to be “long term”. Only those community boreholes in the immediate vicinity of the mining pond are likely to be affected hence the spatial scale is considered to be “site specific” or “local”. The consequence of this impact is therefore rated as “medium”. As there are no community borehole water level records prior to the construction of the Lanti pond, the impact is considered to be “possible”. The significance of the impact is “medium” and “negative” while the confidence of the assessment is “medium”. After the implementation of the management measures, the magnitude of the impact is reduced to “minor” while the duration of the impact remains “long term”. The spatial scale remains “site specific” and the consequence remains “medium”. The probability of exposure to this impact decreases to “unlikely” and the significance of the impact is reduced to “low” while the confidence in the assessment of the management measures is “high”. The result of the impact assessment is summarised in **Table 11-10**.

Table 11-10: Impact 3b - Impact Assessment Summary

<b>Impact 3b: Lowered Lanti Mining Pond Level May Reduce Available Drawdown in Community Boreholes</b>								
	Magnitude	Duration	Scale	Consequence	Probability	Significance	+ / -	Confidence
<b>Before Management</b>	<i>Moderate</i>	<i>Long term</i>	<i>Site / local</i>	<i>Medium</i>	<i>Possible</i>	<b>Medium</b>	-	<i>Medium</i>
<b>Management Measures:</b>								
<ul style="list-style-type: none"> <li>Provide alternative water supply if community boreholes in the immediate vicinity no longer function</li> </ul>								
<b>After Management</b>	<i>Minor</i>	<i>Long term</i>	<i>Site / local</i>	<i>Medium</i>	<i>Unlikely</i>	<b>Low</b>	-	<i>High</i>

#### 11.2.9.4 Proposed Monitoring or Action Plans

Similar to Impact 3a, an updated hydrocensus should be undertaken by SRL to confirm the location of all groundwater extraction points within SR Area 1. It is recommended that the yield of the community boreholes in the immediate vicinity is monitored on a monthly basis to record the current performance. Groundwater levels within the boreholes should also be recorded where possible. Where this is not feasible, the SRL groundwater monitoring network should be used to record the response of the groundwater regime to any lowering of the water levels within the historical mining ponds.

#### 11.2.10 Impact 3c – Lanti Dredge Hydrocarbon and Sewage Spills Contaminating Groundwater (Operational Phase)

##### 11.2.10.1 Description

While the Lanti dredge and wet processing plant is operational, there is a risk of hydrocarbon or sewage spills which may contaminate the groundwater in the immediate vicinity.

##### 11.2.10.2 Proposed Mitigation Measures

The following mitigation measures are recommended:

- Hydrocarbon transportation and storage on the dredge and wet plant should be kept to a minimum to prevent spills into the mining pond;

- Appropriate booms and spill kits should be kept on board so that any spills may be addressed immediately;
- Proper maintenance of all vehicles and machinery to prevent fuel or oil leaks and spillages;
- Vehicles and machinery should be serviced in bunded areas with drip trays;
- A hydrocarbon absorbing product should be kept on site and used to clean up hydrocarbon spills in the event that they should occur, and
- The office area sewage treatment process should be properly maintained to ensure that it is operating within design specification.

### 11.2.10.3 Impact Assessment

Since it is assumed that any incident will be quickly identified, the magnitude of the impact of any hydrocarbon or sewage spill is considered to be “minor” and the duration “short term”. Only groundwater in the immediate vicinity is likely to be affected hence the spatial scale is considered to be “site specific” or “local”. The consequence of this impact is therefore rated as “low”. The probability of the exposure to this impact is considered to be “possible”. The significance of this impact is considered to be “low” and “negative” with the confidence in the assessment rated as “high”. With the implementation of the management measures the only change to the impact assessment is that the probability of exposure reduces from “possible” to “unlikely”. The significance of the impact remains “low” and “negative” while the confidence of the assessment remains “high”. The result of the impact assessment is summarised in **Table 11-11**.

**Table 11-11: Impact 3c - Impact Assessment Summary**

<b>Impact 3c – Lanti Hydrocarbon and Sewage Spills Contaminating Groundwater</b>								
	<b>Magnitude</b>	<b>Duration</b>	<b>Scale</b>	<b>Consequence</b>	<b>Probability</b>	<b>Significance</b>	<b>+ / -</b>	<b>Confidence</b>
<b>Before Management</b>	<i>Minor</i>	<i>Short term</i>	<i>Site / local</i>	<i>Low</i>	<i>Possible</i>	<i>Low</i>	-	<i>High</i>
<b>Management Measures:</b>								
<ul style="list-style-type: none"> <li>• Hydrocarbon transportation and storage on the dredge and wet plant should be kept to a minimum to prevent spills into the mining pond;</li> <li>• Appropriate booms and spill kits should be kept on board so that any spills may be addressed immediately;</li> <li>• Proper maintenance of all vehicles and machinery to prevent fuel or oil leaks and spillages;</li> <li>• Vehicles and machinery should be serviced in bunded areas with drip trays;</li> <li>• A hydrocarbon absorbing product should be kept on site and used to clean up hydrocarbon spills in the event that they should occur, and</li> <li>• The sewage treatment process should be properly maintained to ensure that it is operating within design specification.</li> </ul>								

After Management	Minor	Short term	Site / local	Low	Unlikely	Low	-	High
------------------	-------	------------	--------------	-----	----------	-----	---	------

#### 11.2.10.4 Proposed Monitoring or Action Plans

Standard operating procedures regarding the transportation and storage of hydrocarbons at the Lanti dredge and wet plant should be audited on a regular basis. These audits should also extend to the maintenance and refuelling of equipment onshore. Any discharge from the sewage treatment should be monitored to ensure that the plant is operating within the design limitations.

#### 11.2.11 Impact 3d – Lanti Mining Pond Water May Lead to Groundwater Contamination (Operational Phase)

##### 11.2.11.1 Description

It has been established from historical sampling that the Lanti mining pond water quality is more acidic with a higher TDS than the historical mining ponds. The water quality of any groundwater abstraction wells in close proximity may be affected where the drawdown cone alters the localised groundwater flow patterns.

##### 11.2.11.2 Proposed Mitigation Measures

Alternative water supplies should be provided if monitoring data shows that the Lanti mining pond has affected the water quality in community boreholes to the point where they cannot be used.

##### 11.2.11.3 Impact Assessment

The magnitude of the impact of the community boreholes in the immediate vicinity of the Lanti mining pond no longer being fit for use is considered to be “moderate”. Since the dredge mining operations will continue at Lanti for less than 5 years, the duration is considered to be “medium term”. Only those community boreholes in the immediate vicinity of the mining pond are likely to be affected hence the spatial scale is considered to be “site specific” or “local”. The consequence of this impact is therefore rated as “medium”. As there is uncertainty whether any community boreholes are affected, the impact is considered to be “possible”. The significance of the impact is “medium” and “negative” while the confidence of the assessment is “low”. After the implementation of the management measures, the magnitude of the impact reduces to “minor” while the duration remains “medium term” and the spatial scale remains “site specific” or “local”. The consequence therefore



reduces to “low” and the probability of exposure to this impact decreases to “unlikely”. The consequence of the impact reduces to “low” while the confidence in the assessment of the management measures is “high”. The result of the impact assessment is summarised in **Table 11-12**.

**Table 11-12: Impact 3d - Impact Assessment Summary**

<b>Impact 3d: Lanti Mining Pond Water May Lead to Groundwater Contamination</b>								
	<b>Magnitude</b>	<b>Duration</b>	<b>Scale</b>	<b>Consequence</b>	<b>Probability</b>	<b>Significance</b>	<b>+ /-</b>	<b>Confidence</b>
<b>Before Management</b>	<i>Moderate</i>	<i>Medium term</i>	<i>Site / local</i>	<b>Medium</b>	<b>Possible</b>	<b>Medium</b>	-	<i>Medium</i>
<b>Management Measures:</b>								
<ul style="list-style-type: none"> <li>Provide alternative water supply if the Lanti mining pond has affected the water quality in the community boreholes in the immediate vicinity to the point where they cannot be used.</li> </ul>								
<b>After Management</b>	<i>Minor</i>	<i>Medium term</i>	<i>Site / local</i>	<b>Low</b>	<b>Unlikely</b>	<b>Low</b>	-	<i>High</i>

#### 11.2.11.4 Proposed Monitoring or Action Plans

It is recommended that the water quality of the community boreholes in the immediate vicinity is monitored on a quarterly basis to determine if there is any influence from the Lanti mining pond. Groundwater levels within the boreholes should also be recorded where possible.

#### 11.2.12 Impact 3e – Lowered Lanti Mining Pond Level May Expose Sulphides Leading to Groundwater Acidification (Decommissioning Phase)

##### 11.2.12.1 Description

In the current mine closure plan, the water levels within the Lanti mining pond will be lowered to reduce maintenance and the risk of dam wall failure. This may in turn expose previously inundated sulphides which may lead to acidification and contamination of the groundwater regime in the immediate vicinity.

### 11.2.12.2 Proposed Mitigation Measures

The potentially acid generating material should be identified through sampling and either be rehabilitated to reduce the rate of acidification or be disposed of sub aqueously beneath a permanent water level elevation.

### 11.2.12.3 Impact Assessment

The magnitude of the impact of the exposure of sulphides during the lowering of the Lanti mining pond water levels and subsequent contamination of groundwater is considered to be “moderate”. It is assumed that any reduction in the Lanti mining pond water level is a permanent management measure and the duration is therefore considered to be “long term”. Only groundwater in the immediate vicinity of the Lanti pond is likely to be affected hence the spatial scale is considered to be “site specific” or “local”. The consequence of this impact is therefore rated as “medium”. It is uncertain whether sulphides exist at the base of the Lanti mining pond and the impact is therefore considered to be “possible”. The significance of the impact is “medium” and “negative” while the confidence of the assessment is “low”.

After the implementation of the management measures, the magnitude of the impact is reduced to “minor” while the probability of exposure to this impact remains at “possible”. Nonetheless, the significance of the impact remains “medium” while the confidence in the assessment of the management measures increases to “medium”. The result of the impact assessment is summarised in **Table 11-13**.

**Table 11-13: Impact 3e - Impact Assessment Summary**

<b>Impact 3e: Lowered Lanti Mining Pond Level May Expose Sulphides Leading to Groundwater Acidification</b>								
	Magnitude	Duration	Scale	Consequence	Probability	Significance	+ /-	Confidence
<b>Before Management</b>	<i>Moderate</i>	<i>Long term</i>	<i>Site / local</i>	<b>Medium</b>	<b>Possible</b>	<b>Medium</b>	-	<i>Low</i>
<b>Management Measures:</b>								
<ul style="list-style-type: none"> <li>Sample for sulphides and rehabilitate potentially acid generating material or dispose of sub aqueously beneath a permanent water level elevation.</li> </ul>								
<b>After Management</b>	<i>Minor</i>	<i>Long term</i>	<i>Site / local</i>	<b>Medium</b>	<b>Possible</b>	<b>Medium</b>	-	<i>Medium</i>

#### 11.2.12.4 *Proposed Monitoring or Action Plans*

A sampling program should be undertaken to determine the nature of the sediment at the base of the Lanti mining pond. An updated hydrocensus should be undertaken by SRL to confirm the locality of groundwater users in the area. The groundwater quality in the boreholes in the immediate vicinity should be monitored so that any trends may be recorded to confirm or disprove any impact of the lowering of the Lanti mining pond level on the groundwater quality.

#### 11.2.13 Impact 4a – Gbeni and Gangama Dry Mining Dewatering Leading to Lowered Groundwater Levels (Operational Phase)

##### 11.2.13.1 *Description*

The future Gbeni and Gangama dry mining operations will extend to the base of the orebody which will be below the groundwater surface. This will lead to the formation of a dewatering cone which will lower the groundwater levels within the immediate vicinity.

##### 11.2.13.2 *Proposed Mitigation Measures*

Alternative water supplies will have to be provided where community boreholes in the immediate vicinity are not functional due to the dewatering. Rivers or surface water systems should be diverted away from the mining operations to prevent water loss to the mine workings.

##### 11.2.13.3 *Impact Assessment*

The magnitude of the impact of lowering the groundwater levels in response to dewatering around the dry mining is considered to be “minor” due to the relatively shallow drawdown of less than 10m which is expected. Since dewatering will occur over the following 4 years the duration is considered to be “medium term”. Only groundwater in the immediate vicinity of the dry mining operations is likely to be affected hence the spatial scale is considered to be “site specific” or “local”. The consequence of this impact is therefore rated as “low”. Dewatering will occur and the exposure to this impact is therefore considered to be “definite”. The significance of the impact is “medium” and “negative” while the confidence in the assessment is “high”.

After the implementation of the management measures, the magnitude of the impact remains “minor” and the duration remains “medium term”. The spatial scale remains “site specific” or

“local”. As a result, the consequence of this impact after management measures remains “low”. After management measures the exposure to this impact decreases to “unlikely”. The significance of the impact reduces to “low” while the confidence in the assessment remains at “high”. The result of the impact assessment is summarised in **Table 11-14**.

**Table 11-14: Impact 4a - Impact Assessment Summary**

<b>Impact 4a: Gbeni and Gangama Dry Mining Dewatering Leading to Lowered Groundwater Levels</b>								
	Magnitude	Duration	Scale	Consequence	Probability	Significance	+ / -	Confidence
<b>Before Management</b>	<i>Minor</i>	<i>Medium term</i>	<i>Site / local</i>	<b>Low</b>	<b>Definite</b>	<b>Medium</b>	-	<i>High</i>
<b>Management Measures:</b>								
<ul style="list-style-type: none"> <li>Alternative water supplies will have to be provided where community boreholes in the immediate vicinity are not functional due to the dewatering; and</li> <li>Rivers or surface water systems should be diverted away from the mining operations to prevent water loss to the mine workings.</li> </ul>								
<b>After Management</b>	<i>Minor</i>	<i>Medium term</i>	<i>Site / local</i>	<b>Low</b>	<b>Unlikely</b>	<b>Low</b>	-	<i>High</i>

#### 11.2.13.4 Proposed Monitoring or Action Plans

Shallow piezometers should be installed around the perimeter of the Gbeni and Gangama dry mining operations so that the response of the groundwater gradients to dewatering can be monitored. An updated hydrocensus should be undertaken by SRL to confirm the location of the groundwater users in the area. The yield of any community boreholes should be monitored so that it can be determined whether the dry mining operations have an impact or not. Flow volumes in the surface water systems need to be monitored so that any variation in the surface water volume in response to mining may be determined.

#### 11.2.14 Impact 4b – Gbeni and Gangama Dry Mining Groundwater Gradients Recover Post-Mining (Decommissioning Phase)

##### 11.2.14.1 Description

Following mining at Gbeni and Gangama, dewatering will cease, and the area will be rehabilitated. This will lead to the recovery of the groundwater gradients to ambient conditions.

### 11.2.14.2 Proposed Mitigation Measures

The rehabilitated topography should mimic pre-mining conditions and diverted rivers should be reinstated.

### 11.2.14.3 Impact Assessment

The magnitude of the impact of the recovery of the groundwater gradients to ambient conditions post mining is considered to be “minor”. Since this would be the final land form the duration is considered to be “long term”. Only the groundwater gradients in the immediate vicinity of the dry mining operations are likely to be affected hence the spatial scale is considered to be “site specific” or “local”. The consequence of this impact is therefore rated as “medium”. The potential exposure to this impact is considered to be “definite”. The significance of the impact is therefore “medium”. If the rehabilitation does not mimic the pre-mining topography and diverted rivers are not reinstated, then the impact will be considered to be “negative” while the confidence in the assessment is “high”.

After the implementation of the management measures, the magnitude of the impact remains “minor” and the duration remains “long term”. The spatial scale remains “site specific” or “local”. As a result, the consequence of this impact after management measures remains “medium” and the potential exposure to this impact remains “definite”. The significance of the impact remains “medium”. However, the impact becomes “positive” while the confidence in the assessment remains at “high”. The result of the impact assessment is summarised in **Table 11-15**.

**Table 11-15: Impact 4b - Impact Assessment Summary**

<b>Impact 4b: Gbeni and Gangama Dry Mining Groundwater Gradients Recover Post-Mining</b>								
	Magnitude	Duration	Scale	Consequence	Probability	Significance	+ / -	Confidence
<b>Before Management</b>	<i>Minor</i>	<i>Long term</i>	<i>Site / local</i>	<b>Medium</b>	<b>Definite</b>	<b>Medium</b>	-	<i>High</i>
<b>Management Measures:</b>								
<ul style="list-style-type: none"> <li>The rehabilitated topography should mimic pre-mining conditions and diverted rivers should be reinstated.</li> </ul>								
<b>After Management</b>	<i>Minor</i>	<i>Long term</i>	<i>Site / local</i>	<b>Medium</b>	<b>Definite</b>	<b>Medium</b>	+	<i>High</i>

#### 11.2.14.4 *Proposed Monitoring or Action Plans*

The groundwater recovery should be monitored in the shallow piezometers that are proposed as part of the dewatering operations around the Gbeni and Gangama operations as per the monitoring plan for impact 4a.

#### 11.2.15 Impact 4c – Gangama Dry Mining Groundwater Ingress Adjacent to the Estuary (Operational Phase)

##### 11.2.15.1 *Description*

Although the ore deposit generally has a low permeability, the geological map indicates the occurrence of highly permeable Bullom sediments on the north-western boundary of the Gangama deposit. This area also coincides with the close proximity of the estuary which has a constant piezometric head due to the connection to the ocean.

Since the depth of mining may extend to -5 mamsl, the anticipated groundwater ingress could be 50-fold higher than elsewhere in the dry mining operations.

##### 11.2.15.2 *Proposed Mitigation Measures*

The location of the Bullom sediments should be mapped in relation to the boundary of the Gangama orebody. If these strata cover a significant area that would be affected by mining, then alternative mining methods and environmental/community H&S impact mitigation should be investigated.

##### 11.2.15.3 *Impact Assessment*

The magnitude of the impact of the increased groundwater ingress while dry mining adjacent to the estuary is considered to be “moderate”. Mining would take place for approximately 4 years and the duration is therefore considered to be “medium term”. This greater influx will only occur in the north-western portion of the Gangama deposit hence the spatial scale is considered to be “site specific” or “local”. The consequence of this impact is therefore rated as “medium”. The potential exposure to this impact is considered to be “definite”. The significance of the impact is therefore “medium” and “negative” while the confidence in the assessment is “high”. With the implementation of the management measures the magnitude of the impact reduces to “minor”. The duration remains “medium term” and the spatial scale remains “site specific” or “local”. As a result, the consequence of this impact decreases to “low”. The probability of the potential exposure to this

impact is rated as “unlikely”. Hence the significance of the impact is reduced to “low” and “negative” while the confidence in the assessment remains “high”. The result of the impact assessment is summarised in **Table 11-16**.

**Table 11-16: Impact 4c - Impact Assessment Summary**

<b>Impact 4c: Gangama Dry Mining Groundwater Ingress Adjacent to the Estuary</b>								
	Magnitude	Duration	Scale	Consequence	Probability	Significance	+ / -	Confidence
<b>Before Management</b>	<i>Moderate</i>	<i>Medium Term</i>	<i>Site / local</i>	<b>Medium</b>	<b>Definite</b>	<b>Medium</b>	-	<i>High</i>
<b>Management Measures:</b> <ul style="list-style-type: none"> <li>• The location of the Bullom sediments should be mapped in relation to the boundary of the Gangama orebody, and</li> <li>• If these strata cover a significant area that would be affected by mining, then alternative mining methods and environmental/community H&amp;S impact mitigation should be investigated.</li> </ul>								
<b>After Management</b>	<i>Minor</i>	<i>Medium Term</i>	<i>Site / local</i>	<b>Low</b>	<b>Unlikely</b>	<b>Low</b>	-	<i>High</i>

#### 11.2.15.4 Proposed Monitoring or Action Plans

Piezometers should be installed along the north-western boundary of the deposit to monitor the groundwater level response to the advance of mining. Pumping hours should also be recorded so that there may be advance warning of any substantial increase in the ingress into the mine workings.

#### 11.2.16 Impact 4d – Gbeni and Gangama Dry Mining Hydrocarbons Contaminating Groundwater (Operational Phase)

##### 11.2.16.1 Description

There is a risk of hydrocarbon spills which may contaminate the groundwater during mining at Gbeni and Gangama.

##### 11.2.16.2 Proposed Mitigation Measures

The following mitigation measures are recommended:

- Proper maintenance should be undertaken on all vehicles and machinery to prevent fuel or oil leaks and spillages;
- Vehicles and machinery should be serviced in bunded areas with drip trays, and

- A hydrocarbon absorbing product should be kept on site and used to clean up hydrocarbon spills in the event that they should occur.

### 11.2.16.3 Impact Assessment

Since it is assumed that any incident will be quickly identified, the magnitude of the impact of any hydrocarbon spill is considered to be “minor” and the duration “short term”. Only groundwater in the immediate vicinity is likely to be affected hence the spatial scale is considered to be “site specific” or “local”. The consequence of this impact is therefore rated as “low”. The probability of the exposure to this impact is considered to be “possible”. The significance of this impact is considered to be “low” and “negative” with the confidence in the assessment rated as “high”. With the implementation of the management measures the only change to the impact assessment is that the probability of exposure to this impact reduces from “possible” to “unlikely”. The significance of the impact remains “low” and “negative” while the confidence of the assessment remains “high”. The result of the impact assessment is summarised in **Table 11-17**.

**Table 11-17: Impact 4d - Impact Assessment Summary**

<b>Impact 4d – Gbeni and Gangama Dry Mining Hydrocarbons Contaminating Groundwater</b>								
	<b>Magnitude</b>	<b>Duration</b>	<b>Scale</b>	<b>Consequence</b>	<b>Probability</b>	<b>Significance</b>	<b>+ / -</b>	<b>Confidence</b>
<b>Before Management</b>	<i>Minor</i>	<i>Short term</i>	<i>Site / local</i>	<i>Low</i>	<i>Possible</i>	<i>Low</i>	-	<i>High</i>
<b>Management Measures:</b>								
<ul style="list-style-type: none"> <li>• Proper maintenance should be undertaken on all vehicles and machinery to prevent fuel or oil leaks and spillages;</li> <li>• Vehicles and machinery should be serviced in bunded areas with drip trays, and</li> <li>• A hydrocarbon absorbing product should be kept on site and used to clean up hydrocarbon spills in the event that they should occur.</li> </ul>								
<b>After Management</b>	<i>Minor</i>	<i>Short term</i>	<i>Site / local</i>	<i>Low</i>	<i>Unlikely</i>	<i>Low</i>	-	<i>High</i>

### 11.2.16.4 Proposed Monitoring or Action Plans

Standard operating procedures for the maintenance and refuelling of equipment should be audited on a regular basis. The appropriate spill kits should also be inspected on a regular basis.



### 11.2.17 Impact 4e – Gbeni and Gangama Dry Mining Sulphide Exposure Contaminating Groundwater (Operational and Decommissioning Phase)

#### *11.2.17.1 Description*

SRK (2018) has determined that the general tailings are inert within the mining operations. However, mining at Gbeni and Gangama deposits has predominantly occurred above the groundwater surface. Future mining may expose material which has been under anoxic conditions and which may contain sulphide minerals. Oxidation of this material may lead to further acidification of the groundwater with a potential increase in salinity and heavy metal concentrations.

#### *11.2.17.2 Proposed Mitigation Measures*

The following mitigation measures are proposed:

- The orebody sulphide content beneath the groundwater surface should be established;
- A review of the mineral separation process should be undertaken to confirm that the majority of the high sulphide material can be extracted for selective handling, and
- Any high sulphide material should be deposited sub aqueously or rehabilitated in such a manner that it is isolated from the environment.

#### *11.2.17.3 Impact Assessment*

The magnitude of the impact of the exposure of sulphide minerals during mining at Gbeni and Gangama is considered to be “moderate”. Although mining would take place for approximately 4 years, the acidification process would continue post mining and the duration is therefore considered to be “long term”. Exposure of any sulphides would only occur within the dry mining workings hence the spatial scale is considered to be “site specific” or “local”. The consequence of this impact is therefore rated as “medium”. The potential exposure to this impact is considered to be “possible” since the current sulphide content in the remainder of the ore deposit is unknown. The significance of the impact is therefore “medium” and “negative” while the confidence in the assessment is “medium”. With the implementation of the management measures the magnitude of the impact reduces to “minor”. The duration remains “long term” and the spatial scale remains “site specific” or “local”. As a result, the consequence of this impact remains “medium”. The probability of the potential exposure to this impact remains “possible”. Hence the significance of the impact remains “medium” and “negative” while the confidence in the assessment remains “medium”. The result of the impact assessment is summarised in **Table 11-18**.

Table 11-18: Impact 4e - Impact Assessment Summary

Impact 4e – Gbeni and Gangama Dry Mining Sulphide Exposure Contaminating Groundwater								
	Magnitude	Duration	Scale	Consequence	Probability	Significance	+ /-	Confidence
Before Management	Moderate	Long term	Site / local	Medium	Possible	Medium	-	Medium
<b>Management Measures:</b> <ul style="list-style-type: none"> <li>The orebody sulphide content beneath the groundwater surface should be established;</li> <li>A review of the mineral separation process should be undertaken to confirm that the majority of the high sulphide material can be extracted for selective handling; and</li> <li>Any high sulphide material should be deposited sub aqueously or rehabilitated in such a manner that it is isolated from the environment.</li> </ul>								
After Management	Minor	Long term	Site / local	Medium	Possible	Medium	-	Medium

#### 11.2.17.4 Proposed Monitoring or Action Plans

The water quality from the dewatering operations should be monitored for any changes in acidity or salinity. Piezometers should be installed into the backfilled dry mining areas to monitor the changes in groundwater quality in these areas especially with respect to acidity, salinity and radioactivity.

#### 11.2.18 Impact 4f – Gangama Dry Mining Saline Intrusion Contaminating Groundwater (Operational and Decommissioning Phase)

##### 11.2.18.1 Description

The north-western boundary of the Gangama deposit lies adjacent to the estuary which is subjected to tidal influences. Any dewatering within this immediate vicinity will lead to saline intrusion towards the workings thereby contaminating the groundwater regime.

##### 11.2.18.2 Proposed Mitigation Measures

The following mitigation measures are proposed:

- The extent of the more permeable Bullom sediments should be defined as accurately as possible to identify areas of potential greater ingress;

- If the Bullom strata areas are extensive then alternative mining methods to the current dry mining operations should be considered since excessive volumes of saline water might be generated;
- Groundwater ingress is anticipated to be manageable where the orebody permeability is typically low. However, since the dewatered volume is likely to be saline, this will have to be passed through a settling pond to remove any suspended solids prior to discharge into the estuary. The discharged water quality will have to be monitored to ensure that it complies with legislation;
- Any saline water should be kept separate from other fresh dewatering volumes which may be discharged to nearby freshwater streams, and
- Rehabilitation should consider the extent of any saline intrusion and the impact that this may have on vegetation and the final land use in this area.

#### 11.2.18.3 Impact Assessment

The magnitude of the impact of the potential saline ingress is considered to be “moderate” since the nearby estuary is already subjected to tidal influences. Although mining would take place for approximately 4 years, the saline intrusion would last post mining and may take decades to reverse. The duration is therefore considered to be “long term”. The area for the potential saline intrusion is limited to the north-western boundary of the Gangama dry mining operations hence the spatial scale is considered to be “site specific” or “local”. The consequence of this impact is therefore “medium”. The potential exposure to this impact is considered to be “definite” given the close proximity of the dry mining to the estuary. The significance of the impact is therefore “medium” and “negative” while the confidence in the assessment is “high”. With the implementation of the management measures the magnitude of the impact reduces to “minor”. The duration remains “long term” and the spatial scale remains “site specific” or “local”. As a result, the consequence of this impact remains “medium”. The probability of the potential exposure to this impact remains “possible”. Hence the significance of the impact remains “medium” and “negative” while the confidence in the assessment remains “high”. The impact assessment is summarised in **Table 11-19**.

Table 11-19: Impact 4f - Impact Assessment Summary

Impact 4f – Gangama Dry Mining Saline Intrusion Contaminating Groundwater								
	Magnitude	Duration	Scale	Consequence	Probability	Significance	+ /-	Confidence
Before Management	Moderate	Long term	Site / local	Medium	Definite	Medium	-	High
<b>Management Measures:</b> <ul style="list-style-type: none"> <li>The extent of the more permeable Bullom sediments should be defined as accurately as possible to identify areas of potential greater ingress;</li> <li>If the Bullom strata areas are extensive then alternative mining methods to the current dry mining operations should be considered since excessive volumes of saline water might be generated;</li> <li>Groundwater ingress is anticipated to be manageable where the orebody permeability is typically low. However, since the dewatered volume is likely to be saline, this will have to be passed through a settling pond to remove any suspended solids prior to discharge into the estuary. The discharged water quality will have to be monitored to ensure that it complies with legislation;</li> <li>Any saline water should be kept separate from other fresh dewatering volumes which may be discharged to nearby freshwater streams, and</li> <li>Rehabilitation should consider the extent of any saline intrusion and the impact that this may have on vegetation and the final land use in this area.</li> </ul>								
After Management	Minor	Long term	Site / local	Medium	Possible	Medium	-	High

#### 11.2.18.4 Proposed Monitoring or Action Plans

Shallow piezometers should be installed between the estuary and the proposed mine workings where possible to monitor any changes in groundwater level in response to mining. These locations should also be used to determine any chemical changes to monitor the onset of saline intrusion.

#### 11.2.19 Impact 5a – Nitti Port Hydrocarbon Spillage Contaminating Groundwater (Operational Phase)

##### 11.2.19.1 Description

Nitti Port contains a number of large fuel storage tanks. Leaks or spills from these tanks may cause groundwater contamination. However, given the close proximity of the estuary to the storage tanks, the groundwater mainly acts as a pathway for any contaminants to migrate from the storage tanks to the surface water system where it may be spread relatively rapidly due to currents and tides.

### 11.2.19.2 Proposed Mitigation Measures

Mitigation measures should be identified by specific experts in the field.

### 11.2.19.3 Impact Assessment

The magnitude of the impact of a hydrocarbon spill at Nitti is considered to be “major” given the proximity of the estuary and the volume of fuel storage involved. Since the clean-up from any spill is likely to last beyond 5 years, the duration of the impact is considered to be “long term”. Given the potential for any major spill to spread throughout the estuary and ocean under tidal influences and currents the spatial scale is considered to be “regional”. The consequence of this impact is therefore rated as “high”. The potential exposure to this impact is considered to be “possible”. The significance of the impact is therefore “high” and “negative” while the confidence in the assessment is “high”. Since mitigation measures should be identified by specific experts in this field, there is no impact assessment for the implementation of management measures. The result of the impact assessment is summarised in **Table 11-20**.

**Table 11-20: Impact 5a - Impact Assessment Summary**

<b>Impact 5a – Nitti Port Hydrocarbon Spillage Contaminating Groundwater</b>								
	<b>Magnitude</b>	<b>Duration</b>	<b>Scale</b>	<b>Consequence</b>	<b>Probability</b>	<b>Significance</b>	<b>+ / -</b>	<b>Confidence</b>
<b>Before Management</b>	<i>Major</i>	<i>Long term</i>	<i>Regional</i>	<i>High</i>	<i>Possible</i>	<i>High</i>	-	<i>High</i>
<b>Management Measures:</b>								
<ul style="list-style-type: none"> <li>Management measures should be identified by specific experts in the field.</li> </ul>								

### 11.2.19.4 Proposed Monitoring or Action Plans

An accurate record of the fuel stored onsite at any given time should be maintained with a view to identify any volume discrepancies between replenishment and consumption. This may provide an early warning of any potential subsurface leakage. Given the close proximity of the estuary to the storage tanks and the cost of hydrocarbon analyses, it is recommended that groundwater samples from the monitoring piezometers are taken biannually. However, daily inspection of the base of the tanks and daily monitoring of the estuary and mangroves for signs of any hydrocarbons should be undertaken. Any emergency response plan should be audited on a regular basis with a view to ensure that the extent of any spill is immediately contained.

### 11.2.20 Impact 6a – Waste Disposal Site Leachate Contaminating Groundwater (Operational and Decommissioning Phase)

#### 11.2.20.1 Description

Waste disposal has been undertaken on an ad hoc basis at the small waste disposal site to the north of the MSP. Leachate from this site may contaminate groundwater.

#### 11.2.20.2 Proposed Mitigation Measures

The site should be properly capped and shaped to promote runoff and reduce infiltration.

#### 11.2.20.3 Impact Assessment

The magnitude of the impact of groundwater contamination from any landfill leachate is considered to be “minor” given the size of the current waste disposal site. Since the waste has been buried the duration of the impact is considered to be “long term”. Any leachate will seep into the groundwater within the immediate vicinity before discharging into the surrounding historical mining ponds and the spatial scale is therefore considered to be “site specific” or “local”. The consequence of this impact is therefore rated as “medium”. The potential exposure to this impact is considered to be “possible”. The significance of the impact is therefore “medium” and “negative” while the confidence in the assessment is “high”. With the implementation of the management measures the magnitude of the impact remains “minor”. The duration remains “long term” and the spatial scale remains “site specific” or “local”. The consequence of this impact remains “medium” while the probability of the potential exposure to this impact remains “possible”. Hence the significance of the impact remains “medium” and “negative” while the confidence in the assessment remains “high”. The result of the impact assessment is summarised in **Table 11-21**.

**Table 11-21: Impact 6a - Impact Assessment Summary**

Impact 6a – Waste Disposal Site Leachate Contaminating Groundwater								
	Magnitude	Duration	Scale	Consequence	Probability	Significance	+ / -	Confidence
Before Management	Minor	Long term	Site / local	Medium	Possible	Medium	-	High
<b>Management Measures:</b> <ul style="list-style-type: none"> <li>The waste disposal site should be properly capped and shaped to promote runoff and reduce infiltration.</li> </ul>								

After Management	Minor	Long term	Site / local	Medium	Possible	Medium	-	High
------------------	-------	-----------	--------------	--------	----------	--------	---	------

#### 11.2.20.4 Proposed Monitoring or Action Plans

Monitoring piezometers should be installed both upgradient and downgradient from the waste disposal site so that groundwater samples may be taken on a quarterly basis.

### 11.3 Indirect Impacts

The SRL mining activities that may potentially have indirect impacts through mining induced variations in the groundwater regime within SR Area 1 are as follows:

- Historical and Lanti mining ponds during the operational and decommissioning phase, and
- Gbeni and Gangama dry mining during the operational and decommissioning phase.

The indirect impact of these activities through the groundwater quantity and quality variations will be discussed as follows:

#### 11.3.1 Impact 7a – Raised Historical Mining Pond Levels Altering Groundwater Baseflow Distribution to Surface Water Systems (Operational Phase)

##### 11.3.1.1 Description

The raised water levels in the historical mining ponds have altered the groundwater gradients in the immediate vicinity. This will also have affected the groundwater baseflow distribution to the surface water systems.

##### 11.3.1.2 Proposed Mitigation Measures

No proposed mitigation measures are recommended for this impact since the environment has already adjusted to the altered baseflow as the historical mining ponds have been in place for such a long duration.

##### 11.3.1.3 Impact Assessment

The magnitude of the impact of the baseflow variation due to the raised historical mining pond levels is considered to be “minor”. The current historical mining pond water levels may be in place

for longer than 5 years and the duration of the impact is therefore considered to be “long term”. Since the baseflow that is affected is restricted to the catchments of the historical mining ponds and their immediately adjacent valleys, the spatial scale is considered to be “site specific” or “local”. The consequence of this impact is therefore rated as “medium”. The potential exposure to this impact is considered to be “definite”. The significance of the impact is therefore “medium” and “negative” while the confidence in the assessment is “medium”. No mitigation measures are proposed for this impact. The result of the impact assessment is summarised **Table 11-22**.

**Table 11-22: Impact 7a - Impact Assessment Summary**

<b>Impact 7a – Raised Historical Mining Pond Levels Altering Groundwater Baseflow Distribution to Surface Water Systems</b>								
	<b>Magnitude</b>	<b>Duration</b>	<b>Scale</b>	<b>Consequence</b>	<b>Probability</b>	<b>Significance</b>	<b>+ /-</b>	<b>Confidence</b>
<b>Before Management</b>	<i>Minor</i>	<i>Long term</i>	<i>Site / local</i>	<b>Medium</b>	<b>Definite</b>	<b>Medium</b>	-	<i>Medium</i>
<b>Management Measures:</b>								
<ul style="list-style-type: none"> <li>No mitigation measures are proposed for this impact.</li> </ul>								
<b>After Management</b>	<i>Minor</i>	<i>Long term</i>	<i>Site / local</i>	<b>Medium</b>	<b>Definite</b>	<b>Medium</b>	-	<i>Medium</i>

#### 11.3.1.4 Proposed Monitoring or Action Plans

A groundwater model will be used to determine the order of magnitude for the baseflow variations to the various surface water systems. Surface water flow volumes should be monitored in the rivers in the immediate vicinity so that the response of the environment to the historical mining ponds may be determined.

#### 11.3.2 Impact 7b – Lowered Historical Mining Pond Levels Altering Groundwater Baseflow Distribution to Surface Water Systems (Decommissioning Phase)

##### 11.3.2.1 Description

In the current mine closure plan, the water levels within the historical mining ponds will be lowered to reduce maintenance and the risk of dam wall failure. This will also alter the groundwater baseflow distribution to the surface water systems in the immediately adjacent valleys. The baseflow will



adjust to the new lowered mining pond levels until approximate steady state conditions are achieved.

### 11.3.2.2 Proposed Mitigation Measures

No proposed mitigation measures are proposed for this impact.

### 11.3.2.3 Impact Assessment

The magnitude of the impact of the baseflow variation due to the lowered historical mining pond levels is considered to be “minor”. Since the lowering of the historical mining pond water levels forms part of the mine closure plan, the duration of the impact is considered to be “long term”.

It is anticipated that the historical mining pond dam walls will not be completely removed and hence the baseflow within the historical mining pond catchments would remain restricted. This would mean that the greatest changes in baseflow would occur within the valleys adjacent to the historical mining ponds and the spatial scale is therefore considered to be “site specific” or “local”. The consequence of this impact is therefore rated as “medium”. The potential exposure to this impact is considered to be “definite”. The significance of the impact is therefore “medium” and “negative” while the confidence in the assessment is “medium”. No mitigation measures are proposed for this impact. The result of the impact assessment is summarised **Table 11-23**.

**Table 11-23: Impact 7b - Impact Assessment Summary**

<b>Impact 7b – Lowered Historical Mining Pond Levels Altering Groundwater Baseflow Distribution to Surface Water Systems</b>								
	<b>Magnitude</b>	<b>Duration</b>	<b>Scale</b>	<b>Consequence</b>	<b>Probability</b>	<b>Significance</b>	<b>+ / -</b>	<b>Confidence</b>
<b>Before Management</b>	<i>Minor</i>	<i>Long term</i>	<i>Site / local</i>	<i>Medium</i>	<i>Definite</i>	<b>Medium</b>	-	<i>Medium</i>
<b>Management Measures:</b>								
<ul style="list-style-type: none"> <li>No mitigation measures are proposed for this impact.</li> </ul>								
<b>After Management</b>	<i>Minor</i>	<i>Long term</i>	<i>Site / local</i>	<i>Medium</i>	<i>Definite</i>	<b>Medium</b>	-	<i>Medium</i>

#### 11.3.2.4 Proposed Monitoring or Action Plans

A groundwater model will be used to determine the order of magnitude for the baseflow variations to the various surface water systems. Surface water flow volumes should be monitored in the rivers in the immediate vicinity so that the response of the environment to the lowering of the historical mining pond water levels may be determined.

### 11.3.3 Impact 8a – Lanti Mining Pond Retarding Groundwater Baseflow to Surface Water Systems (Operational and Decommissioning Phase)

#### 11.3.3.1 Description

Lanti mining pond was created by the construction of engineered earth impoundments across the river valley. This has resulted in the retardation of the baseflow to the surface water systems. This scenario will continue post mining since it is anticipated that the earth impoundment will remain in place albeit with a lowered water level.

#### 11.3.3.2 Proposed Mitigation Measures

No proposed mitigation measures are recommended for this impact since the environment has already adjusted to the altered baseflow as the Lanti mining pond has been in place for such a long duration.

#### 11.3.3.3 Impact Assessment

The magnitude of the impact of the retardation of the baseflow is considered to be “minor”. Since it is anticipated that the Lanti mining pond wall will remain in place post mining, the duration of the impact is considered to be “long term”. In this case the restriction of the baseflow is limited to the catchment of the Lanti mining pond and the spatial scale is therefore considered to be “site specific” or “local”. The consequence of this impact is therefore rated as “medium”. The potential exposure to this impact is considered to be “definite”. The significance of the impact is therefore “medium” and “negative” while the confidence in the assessment is “high”. No mitigation measures are proposed for this impact. The result of the impact assessment is summarised in **Table 11-24**.

Table 11-24: Impact 8a - Impact Assessment Summary

Impact 8a – Lanti Mining Pond Retarding Groundwater Baseflow to Surface Water Systems								
	Magnitude	Duration	Scale	Consequence	Probability	Significance	+ /-	Confidence
Before Management	Minor	Long term	Site / local	Medium	Definite	Medium	-	High
<b>Management Measures:</b> <ul style="list-style-type: none"> <li>No mitigation measures are proposed for this impact.</li> </ul>								
After Management	Minor	Long term	Site / local	Medium	Definite	Medium	-	High

#### 11.3.3.4 Proposed Monitoring or Action Plans

A groundwater model will be used to determine the order of magnitude for the baseflow variations to the various surface water systems. Surface water flow volumes should be monitored downstream in the immediate vicinity so that the response of the environment to the Lanti mining pond may be determined.

#### 11.3.4 Impact 8b – Seepage of Poor Quality Groundwater Through The Lanti Mining Pond Wall and Weathered Aquifer Discharging Into The Surface Water Systems (Operational Phase)

##### 11.3.4.1 Description

Historical sampling has shown that the water quality within the Lanti mining pond is more acidic and has a higher TDS than the historical mining ponds. Some of this water seeps through the earth impoundment and weathered aquifer as groundwater and discharges into the surface water downstream. It is anticipated that the pond water quality will improve post mining.

##### 11.3.4.2 Proposed Mitigation Measures

Since the groundwater seepage through the mining pond wall and weathered aquifer is relatively insignificant when compared to the surface water decant volume from the pond, no mitigation measures are proposed.

##### 11.3.4.3 Impact Assessment

The magnitude of the impact of any poor-quality groundwater seepage through the dam wall and weathered aquifer is considered to be “minor”. Since the Lanti dredge operations will continue for

approximately 18 months the duration of the impact is considered to be “medium term”. After this period the groundwater quality is likely to improve. The groundwater seepage occurs at the Lanti mining pond wall and the spatial scale is therefore considered to be “site specific” or “local”. The consequence of this impact is therefore rated as “low”. The potential exposure to this impact is considered to be “definite”. The significance of the impact is therefore “medium” and “negative” while the confidence in the assessment is “high”. No mitigation measures are proposed for this impact. The result of the impact assessment is summarised **Table 11-25**.

**Table 11-25: Impact 8b - Impact Assessment Summary**

<b>Impact 8b – Seepage of Poor Quality Groundwater Through The Lanti Mining Pond Wall and Weathered Aquifer Discharging Into The Surface Water Systems</b>								
	<b>Magnitude</b>	<b>Duration</b>	<b>Scale</b>	<b>Consequence</b>	<b>Probability</b>	<b>Significance</b>	<b>+ / -</b>	<b>Confidence</b>
<b>Before Management</b>	<i>Minor</i>	<i>Medium term</i>	<i>Site / local</i>	<b>Low</b>	<b>Definite</b>	<b>Medium</b>	-	<i>High</i>
<b>Management Measures:</b>								
<ul style="list-style-type: none"> <li>No mitigation measures are proposed for this impact.</li> </ul>								
<b>After Management</b>	<i>Minor</i>	<i>Medium term</i>	<i>Site / local</i>	<b>Low</b>	<b>Definite</b>	<b>Medium</b>	-	<i>High</i>

#### 11.3.4.4 Proposed Monitoring or Action Plans

The Lanti mining pond wall should be inspected on a regular basis to monitor the volume of groundwater seepage through the earth impoundment.

#### 11.3.5 Impact 9a – Failure of the Historical and Lanti Mining Pond Walls As a Result of Groundwater Seepage (Operational and Decommissioning Phase)

##### 11.3.5.1 Description

The historical and Lanti mining ponds have sand blankets built into the impoundment wall to reduce the internal phreatic surface. Nonetheless, excessive groundwater seepage through these structures may affect the stability. The raised water levels in the historical and Lanti mining ponds has resulted in additional groundwater seepage through the earth impoundments.

### 11.3.5.2 Proposed Mitigation Measures

In the current mine closure plan, the water levels within the mining ponds will be lowered to reduce maintenance and risk of wall failure. Tailings should be deposited downstream of the walls to ensure greater stability.

### 11.3.5.3 Impact Assessment

Given the size of the mining ponds the magnitude of the impact of dam failure due to groundwater seepage is considered to be “major” due to the potential loss of life and damage downstream. The destruction associated with a dam wall failure is substantial and the duration of the impact is considered to be “long term”. The affected area from a dam wall failure would extend beyond the site boundaries. However, the implications will extend beyond the region and the spatial scale is therefore considered to be “national”. The consequence of this impact is therefore rated as “high”. The potential exposure to this impact is considered to be “possible”. The significance of the impact is therefore “high” and “negative” while the confidence in the assessment is “high”. Following the implementation of the mitigation measures the magnitude of the impact remains “major” and the duration remains “long term”. Since the spatial scale is still considered to be “national”, the consequence of this impact is still rated as “high”. However, the potential exposure to this impact with management measures is reduced to “unlikely”. The significance of the impact is therefore reduced to “medium” and “negative” while the confidence in the assessment remains “high”. The result of the impact assessment is summarised **Table 11-26**.

**Table 11-26: Impact 9a – Impact Assessment Summary**

Impact 9a – Failure of the Historical and Lanti Mining Pond Walls As a Result of Groundwater Seepage								
	Magnitude	Duration	Scale	Consequence	Probability	Significance	+ / -	Confidence
Before Management	Major	Long term	National	High	Possible	High	-	High
<b>Management Measures:</b> <ul style="list-style-type: none"> <li>In the current mine closure plan, the water levels within the mining ponds will be lowered to reduce maintenance and risk of wall failure, and</li> <li>Tailings should be deposited downstream of the mining pond walls to ensure greater stability.</li> </ul>								
After Management	Major	Long term	National	High	Unlikely	Medium	-	High

#### 11.3.5.4 Proposed Monitoring or Action Plans

The groundwater levels within the mining pond walls should continue to be monitored as input into a stability assessment of the earth impoundments. The walls should be regularly inspected for signs of failure or excessive seepage through the downgradient face.

#### 11.3.6 Impact 10a – Gbeni and Gangama Dry Mining Slope Failure As a Result of Groundwater Seepage (Operational Phase)

##### 11.3.6.1 Description

Future Gbeni and Gangama dry mining operations will occur beneath the groundwater surface. Dewatering will be required presumably through the use of trenches given the low permeability of the orebody. Groundwater seepage towards the trenches is an influencing factor for the slope stability of the dry mining operations.

##### 11.3.6.2 Proposed Mitigation Measures

The groundwater levels should be lowered as much as possible ahead of mining to reduce the risk of failure. Slopes of the dry mining operations should be reduced appropriately to minimize slope stability risks.

##### 11.3.6.3 Impact Assessment

The magnitude of the impact of groundwater seepage induced slope failure is considered to be “moderate”. Since the depth of the dry mining is relatively shallow it is anticipated that any slope failure could be repaired within a year. The duration of the impact is therefore considered to be “short term”. Slope failure would be limited to the dry mining operations and the spatial scale is therefore considered to be “site specific” or “local”. The consequence of this impact is therefore rated as “low”. The potential exposure to this impact is considered to be “possible”. The significance of the impact is therefore “low” and “negative” while the confidence in the assessment is “high”. Following the implementation of mitigation measures the magnitude of the impact is reduced to “minor” while the duration remains “short term”. The spatial scale remains “site specific” or “local”. The consequence of this impact therefore remains “low”. However, the potential exposure to this impact with management measures is reduced to “unlikely”. Nonetheless, the significance of the impact remains “low” and “negative” while the confidence in the assessment remains “high”. The result of the impact assessment is summarised **Table 11-27**.

Table 11-27: Impact 10a - Impact Assessment Summary

Impact 10a – Gbeni and Gangama Dry Mining Slope Failure As a Result of Groundwater Seepage								
	Magnitude	Duration	Scale	Consequence	Probability	Significance	+ /-	Confidence
Before Management	Moderate	Short term	Site / local	Low	Possible	Low	-	High
<b>Management Measures:</b> <ul style="list-style-type: none"> <li>Groundwater levels should be lowered as much as possible ahead of mining to reduce the risk of failure, and</li> <li>Slopes of the dry mining operations should be reduced appropriately to minimize slope stability risks.</li> </ul>								
After Management	Minor	Short term	Site / local	Low	Unlikely	Low	-	High

#### 11.3.6.4 Proposed Monitoring or Action Plans

Shallow piezometers should be installed ahead of mining to confirm the effectiveness of any dewatering efforts. The dry mining walls should be regularly inspected for signs of failure or excessive seepage.

#### 11.3.7 Impact 10b – Gbeni and Gangama Dry Mining Saturation Due to Groundwater Ingress (Operational Phase)

##### 11.3.7.1 Description

Dewatering will be required for the future Gbeni and Gangama dry mining operations. Although the current information suggests that the orebody has a low permeability, the orebody may remain saturated as a result which may affect production.

##### 11.3.7.2 Proposed Mitigation Measures

The proposed remedial measures are as follows:

- Surface water courses should be diverted away from the perimeter of the dry mining operations where possible to reduce water recirculation;
- The mining operations surface should be shaped in such a manner as to promote rapid runoff with minimal infiltration;
- High permeable zones should be identified prior to the advance of mining particularly any occurrence of Bullom sediments;

- Dewatering trenches, sumps and pumping equipment should be sized correctly to cater for any sudden ingress, and
- Dewatering should occur ahead of mining to ensure that the groundwater levels have been lowered sufficiently to increase the margin of safety.

### 11.3.7.3 Impact Assessment

The magnitude of the impact of saturated conditions in the Gbeni and Gangama dry mining operations due to groundwater ingress is considered to be “moderate”. Mining operations will occur over the following 4 years and the duration is therefore considered to be “medium term”. Only the immediate dry mining operations are affected hence the spatial scale is considered to be “site specific” or “local”. The consequence of this impact is therefore rated as “medium”. Based on the available field observations the potential exposure to this impact is considered to be “definite”. The significance of the impact is “medium” and “negative” while the confidence in the assessment is “high”.

After the implementation of the management measures, the magnitude of the impact is reduced to “minor” while the duration remains “medium term”. The spatial scale remains “site specific” or “local”. The consequence of this impact after management measures is therefore reduced to “low”. After management measures the probability of exposure to this impact reduces to “possible”. The significance of the impact therefore reduces to “low” while the confidence in the assessment remains at “high”. The result of the impact assessment is summarised in **Table 11-28**.

**Table 11-28: Impact 10b: Impact Assessment Summary**

Impact 10b: Gbeni and Gangama Dry Mining Saturation Due to Groundwater Ingress								
	Magnitude	Duration	Scale	Consequence	Probability	Significance	+ /-	Confidence
Before Management	<i>Moderate</i>	<i>Medium term</i>	<i>Site / local</i>	<i>Medium</i>	<i>Definite</i>	<i>Medium</i>	-	<i>High</i>
<b>Management Measures:</b>								
<ul style="list-style-type: none"> <li>• Surface water courses should be diverted away from the perimeter of the dry mining operations where possible to reduce water recirculation;</li> <li>• The mining operations surface should be shaped in such a manner as to promote rapid runoff with minimal infiltration;</li> <li>• High permeable zones should be identified prior to the advance of mining particularly any occurrence of Bullom sediments;</li> <li>• Dewatering trenches, sumps and pumping equipment should be sized correctly to cater for any sudden ingress, and</li> <li>• Dewatering should occur ahead of mining to ensure that the groundwater levels have been lowered sufficiently to</li> </ul>								



increase the margin of safety.								
After Management	Minor	Medium term	Site / local	Low	Possible	Low	-	High

#### 11.3.7.4 Proposed Monitoring or Action Plans

Shallow piezometers should be installed around the perimeter of the Gbeni and Gangama dry mining operations and ahead of mining to confirm that the dewatering trenches are effective. Pumping hours should be recorded so that trends in the dewatering volumes may be monitored. Any signs of water ponding should be addressed immediately so that additional infiltration is minimized.

#### 11.3.8 Impact 10c – Suspended Solids from the Gbeni and Gangama Dry Mining Dewatering Volumes Contaminating Surface Water (Operational Phase)

##### 11.3.8.1 Description

Dewatering will occur as the dry mining operations at Gbeni and Gangama extend beneath the groundwater surface. It is anticipated that this groundwater will be intercepted by trenches and pumped into the surface water systems. Any suspended solids that are contained within this water may have an impact on the surface water quality.

##### 11.3.8.2 Proposed Mitigation Measures

The dewatering volumes should be pumped into a settling pond or wetland so that the water quality can be improved prior to the discharge to the surface water systems.

##### 11.3.8.3 Impact Assessment

The magnitude of the impact of suspended solids from the dewatering volumes is considered to be “minor” given the relatively low dewatering volumes that are expected. Since the dry mining operations will continue for another 4 years the duration of the impact is considered to be “medium term”. The discharge occurs from the dry mining operations and the spatial scale is therefore considered to be “site specific” or “local”. The consequence of this impact is therefore rated as “low”. The potential exposure to this impact is considered to be “possible”. The significance of the impact is therefore “low” and “negative” while the confidence in the assessment is “high”. Following the implementation of the mitigation measures the magnitude of the impact remains “low” and the

duration remains “medium term”. The spatial scale remains “site specific” or “local”. The consequence of the impact therefore remains “low”. After the implementation of the management measures the potential exposure to the impact is reduced to “unlikely”. Therefore, the significance of the impact remains “low” and “negative” while the confidence in the assessment remains “high”. The result of the impact assessment is summarised **Table 11-29**.

**Table 11-29: Impact 10c - Impact Assessment Summary**

Impact 10c – Suspended Solids from the Gbeni and Gangama Dry Mining Dewatering								
Volumes Contaminating Surface Water								
	Magnitude	Duration	Scale	Consequence	Probability	Significance	+ / -	Confidence
Before Management	Minor	Medium term	Site / local	Low	Possible	Low	-	High
<b>Management Measures:</b> <ul style="list-style-type: none"> <li>The dewatering volumes should be pumped into a settling pond or wetland so that the water quality can be improved prior to the discharge to the surface water systems.</li> </ul>								
After Management	Minor	Medium term	Site / local	Low	Unlikely	Low	-	High

#### 11.3.8.4 Proposed Monitoring or Action Plans

The water quality of the dewatering discharge should be continuously monitored to ensure that it complies with the effluent standards as laid out in the relevant legislation described in section 8.6

## 11.4 Cumulative Impacts

The majority of the impacts from mining operations on groundwater in SR Area 1 are localized and site specific. Cumulative impacts from the operations are not expected.

## 12 ASSUMPTIONS AND LIMITATIONS

The following assumptions and limitations apply to this investigation.

### 12.1 Assumptions

The assumptions for this investigation are as follows:

- The weathered/fresh basement contact is laterally heterogeneous over short distances. It is therefore cost prohibitive to define this hydrostratigraphic layer in detail. The current monitoring borehole data points are therefore considered to be a reasonable reflection of this aquifer;
- The unconsolidated sediments and weathered basement have similar characteristics. These two strata have therefore been grouped together as one hydrostratigraphic unit;
- Since the unconsolidated sediments generally have low yields, a single screened well is considered sufficient to determine the aquifer parameters across the site. Exceptions include the dry mining operations where borehole pairs have differentiated between the orebody and the underlying weathered/fractured basement contact;
- Rainfall recharge has been determined from the SRK surface water modelling. This is considered to be a sufficient starting point for this investigation and subsequent groundwater modelling, and
- Groundwater sampling has not been undertaken at the time of writing this report. The historical monitoring data is therefore considered to be sufficient for the preliminary assessment at present.

### 12.2 Limitations

The following limitations apply to this investigation:

- There is limited transient monitoring data especially in terms of groundwater levels. The preliminary subsequent modelling will therefore be calibrated in steady state;
- Monitoring points around the potential MSP sources still need to be installed since a number of these have been vandalised. The subsequent groundwater modelling will assist in the siting of these points, and
- The order of magnitude for the dewatering volumes in the dry mining operations is currently unknown. This will be determined during the subsequent groundwater modelling exercise.

### 13 MITIGATION MEASURES

The following mitigation measures are recommended for further investigation:

- The waste disposal site should be appropriately rehabilitated and capped to minimize infiltration and leachate generation;
- Hydrocarbon spills should be minimized by maintaining mining equipment, servicing and refuelling equipment in bunded areas and keeping a hydrocarbon absorbing product on site to clean up hydrocarbon spills in the event that they should occur;
- Booms and dispersants should be kept at the Lanti dredge and Nitti Port to immediately contain and clean up any hydrocarbon spill that may occur;
- Specialists should determine the appropriate management measures for the fuel storage tanks at Nitti Port;
- The historical and Lanti mining pond water levels should be lowered as soon as possible to reduce the risk of dam wall failure. Tailings should also be disposed of downstream of the dam walls to provide additional support for closure;
- High sulphide material in the MSP secondary processed tailings should be identified and either disposed of sub aqueously or rehabilitated in such a manner so as to isolate it from the environment;
- The MSP secondary processed tailings should be progressively rehabilitated to minimize infiltration and seepage through this material;
- The rivers around the dry mining operations should be sufficiently diverted to prevent recirculation of water and the loss of baseflow to the dewatering cone that will develop around these areas;
- The surface of the dry mining operations should be sloped in such a manner so as to promote rainfall runoff rather than ponding water which will increase infiltration;
- Dewatering should take place ahead of dry mining by means of trenches. The trenches, sumps and pumping capacity should be appropriately sized to handle sudden groundwater ingress or rainfall events;
- Slopes of the dry mining operations should be reduced appropriately to minimize slope stability risks;
- Any high sulphide material that is identified in the remaining orebody at Gbeni and Gangama should be handled selectively by sub aqueous disposal or placed in an appropriately lined and rehabilitated area. This also applies to any sulphides that may be exposed if the historical and Lanti mining pond water levels are lowered;

- Settling ponds or wetlands should be constructed to receive the dewatering volumes from the dry mining operations prior to discharge to the environment. This will allow the suspended solids to settle and the overall water quality to improve;
- The settling pond locations should take the original surface water catchment into account so that the discharge supplements any baseflow losses that may have resulted due to mining;
- Saline intrusion will be a factor if dry mining is undertaken in close proximity to the estuary in the northern extremity of the Gangama deposit. This water should be intercepted and discharged back into the estuary after passing through settling ponds provided that the water is of an acceptable water quality. These settling ponds should be kept separate from those receiving fresh dewatered volumes from the remainder of the ore deposit;
- Alternative mining methods to dry mining should be considered for areas that contain significant Bullom sediments as this may lead to excessive groundwater ingress. This would also mitigate the possibility of saline intrusion in the north-western portion of the Gangama deposit; and
- Communities should be provided with alternative water supplies if it is determined that mining has rendered the boreholes unfit for use.

## 14 POST MINING CONDITIONS

It is Graell's understanding that the post mining land use will be similar to pre-mining conditions. In this case this would be agricultural land for the local communities. This has the following implications:

- The groundwater gradients should revert to approximately pre-mining conditions provided any diverted surface water courses are reinstated in a similar location and the post mining landform approximates the pre-mining topography. Lowering the mining pond water levels will assist in this regard;
- Based on historical monitoring of the mining ponds, the post mining groundwater quality is anticipated to revert to background levels over time. This assumes that acid generating, or radioactive material has been appropriately rehabilitated and isolated from the environment;
- Al, Cu, Fe, K, Mn, SO<sub>4</sub> and Zn will specifically require monitoring since they have the potential to exceed the background surface water concentrations in leachate from the primary tailings, and
- Saline intrusion may affect the post mining land use along the north-western boundary of the Gangama deposit. Rehabilitation strategies will have to be evaluated for these conditions.

## 15 MONITORING REQUIREMENTS

The following recommendations are made in terms of monitoring requirements.

### 15.1 Groundwater Monitoring Network

SRK (2013) has identified the groundwater sampling points that have been monitored in the past. The locations are a combination of community boreholes and SRL piezometers, a number of which have been vandalized and will need to be reinstated.

It is recommended that the historical groundwater sampling points are reviewed following an updated hydrocensus that should be undertaken by the SRL within SR Area 1.

The proposed groundwater monitoring network for SR Area 1 should consist of the following:

- The 19 monitoring boreholes drilled during this investigation;
- The historical SRL monitoring points;
- Any additional community boreholes identified during an updated hydrocensus;
- Piezometers installed to monitor the potential pollution sources at the MSP and waste disposal site once the groundwater modelling has been completed;
- Additional piezometers installed to monitor the response of the groundwater regime to dewatering in the dry mining areas, and
- Piezometers installed into the dry mining backfill areas to determine the post mining water quality trends.

### 15.2 Monitoring Frequency and Parameters

The groundwater levels within the monitoring network as described above should be monitored on a monthly basis. Information regarding the yield and water consumption should also be recorded for the community boreholes. Weekly groundwater level measurements will be required for the piezometers installed around the dry mining operations due to the relatively rapid changes that take place here.

Groundwater quality should be sampled on a quarterly basis as prescribed by the Sierra Leonean Legislation and WHO (2017) drinking water standards. The number of the groundwater quality monitoring points is currently set at 35. The location of these latter points will be confirmed once

the groundwater monitoring network has been finalized. However, preference will be given to those community boreholes which are in close proximity to the mining operations.

It is recommended that the following chemical constituents are analysed:

- Field analysis: water levels, EC, pH, redox and dissolved oxygen;
- Laboratory analysis: major ions, hydroxide alkalinity, TDS, pH and dissolved metals, and
- Radionuclides including U, Th, Ra-226, Ra-228, gross alpha, gross beta at locations of potential concern.

### 15.3 Additional Monitoring Requirements

The following components should also be monitored so that the response of the groundwater regime to the SRL mining operations may be correctly evaluated:

- Surface water flow volumes should be monitored in the rivers in the immediate vicinity so that the response of the environment to the mining ponds and dry mining dewatering may be determined;
- The MSP sewage treatment discharge should be monitored to ensure that the plant is operating correctly;
- The dry mining dewatering discharge water quality should be monitored after the recommended settling ponds or wetlands to ensure that it complies with the Sierra Leone effluent standards;
- Pumping hours for the dry mining sumps should be recorded so that trends in the dewatering volumes may be determined;
- An accurate record of the fuel stored at Nitti Port should be maintained with a view to identify any volume discrepancies between supply and consumption. This may provide an early warning of any potential subsurface leakage;
- Regular integrity tests should be undertaken on the fuel storage tanks at Nitti Port;
- A daily inspection of the base of the fuel storage tanks at Nitti Port and the estuary for signs of any hydrocarbons should be undertaken;
- The groundwater levels within the mining pond walls should continue to be monitored as input into a stability assessment of the earth impoundments. The walls should be regularly inspected for signs of failure or excessive seepage through the downgradient face;



- The dry mining box cut side walls should be regularly inspected for signs of failure or excessive seepage, and
- The gross alpha and gross beta should continue to be monitored in the vicinity of the MSP secondary tailings and Mogbwemo dredge pond.

The specific details regarding the sampling locations, protocols and frequency will be updated in the monitoring plan which is compiled as a separate document by SRK.

## 16 CONCLUSIONS

The following conclusions may be drawn from this investigation:

- Tertiary to Recent sediments overlie the gneissic basement of the Kasila Group which covers the majority of the SR Area 1. Bullom sediments are located on the western boundary of the study area within a coastal strip;
- The relatively impermeable fresh basement forms the effective base of the hydrogeological regime;
- Given the close proximity to source, the unconsolidated Tertiary and Recent sediments have similar hydrogeological characteristics to the weathered basement and as such have been grouped together as a hydrostratigraphic unit;
- The underlying weathered/fresh basement contact yields a relatively consistent if variable water strike and has been identified as a second hydrostratigraphic unit;
- Groundwater gradients currently mimic the topography suggesting a limited influence of mining to date;
- Rainfall recharge has been simulated by SRK to be in the order of 0.17% - 2.6% MAP;
- The poorly sorted unconsolidated sediments and weathered bedrock tend to have a low transmissivity (0.12 m<sup>2</sup>/day – 6 m<sup>2</sup>/day) whereas the weathered/fractured basement contact has a wider transmissivity range (6 m<sup>2</sup>/day – 200 m<sup>2</sup>/day) depending on the nature of the contact at a specific location;
- The Bullom sediments have the highest transmissivity which is estimated to be in the order of 300m<sup>2</sup>/day;
- The primary mining method has historically been dredge mining. During 2013, SRL commenced a distinct open cast mining operation (dry mining) as an auxiliary method of ore extraction. It is anticipated that, over time, dredge mining will cease, and dry mining would be the primary mining method employed;
- Lanti and the historical mining ponds were created by damming the river valleys behind engineered earthen walls to facilitate dredge mining within the alluvial sediments. Mining no longer takes place within the historical mining ponds which are now used by the local population as a domestic water source;
- The impact of the mining ponds on the groundwater levels and baseflow is limited to the immediately adjacent river valleys;

- Given the low permeability of the ore deposit, the groundwater ingress volumes into the dry mining operations should be manageable and dewatering may be achieved through the use of trenches which are connected to sumps at the lowest elevation;
- Substantially higher groundwater ingress volumes are anticipated should the mining operations encounter Bullom sediments such as at Foinda village at Gbeni and in the northern extent of the Gangama deposit. Alternative mining methods may have to be considered under these circumstances;
- Ore is located within the vicinity of the pineapple farm immediately adjacent to the Lanti dredge pond. Monitoring borehole SRL17/14 in this area has a blow yield of 32 l/sec which suggests very high permeabilities associated with the underlying Bullom sediments. It is planned that this area will be dredged to avoid substantial water ingress during dry mining;
- Upon mine closure, the groundwater gradients are expected to recover to their ambient levels especially if the post mining topography reflects the pre-mining conditions and diverted rivers are reinstated. The lowering of the mining pond levels will also assist in this regard;
- The ambient groundwater quality is slightly to moderately acidic (pH 4.38) with a low TDS (5.56 mg/l to 77.9 mg/l) as expected in heavily leached environments in humid tropical climates;
- Community boreholes indicate extensive bacteriological contamination which is attributed to human defecation;
- Except for pH and aluminium, historical sampling has shown that the water quality within SR Area 1 generally falls within the WHO drinking water standards and the Sierra Leone Environment Protection (Mines and Minerals) Regulations (2013) effluent standards;
- Although the Lanti mining pond has a lower pH and higher TDS than the historical mining ponds, the water quality is expected to improve post mining;
- The primary process tailings are inert. However, SRK has determined that elevated concentrations of Al, Cu, Fe, K, Mn, SO<sub>4</sub> and Zn in the leachate from this material relative to background surface water are expected;
- Changes to groundwater quality due to the SRL operations are greatest around the secondary processed tailings disposal area at the MSP plant. This area will have to be rehabilitated to reduce the impact on post mining water quality;
- The WHO drinking water standards for gross alpha and gross beta in the secondary processed tailings are exceeded. However, process/surface water locations downstream of

the Mogbwemo dredge pond did not exceed WHO guidelines, indicating a minimal impact from these discharge sources;

- Saline intrusion will be a factor if dry mining is undertaken in close proximity to the estuary in the northern extremity of the Gangama deposit. Rehabilitation and mining alternatives will need to be considered especially if the area is underlain by Bullom sediments;
- The impact assessment has shown that the majority of the mining impacts on groundwater are localized;
- The greatest risk associated with groundwater is the contribution to dam wall failure and a major hydrocarbon spill at Nitti Port from the storage tanks, and
- Impacts from the SRL mining operations may be improved with the implementation of the recommended mitigation and monitoring measures.

## 17 RECOMMENDATIONS

The following recommendations are made:

- Data should be kept for the LOM;
- Potential scenarios where SRL inadvertently mixes or dilutes any discharge or effluent requires careful consideration since this is prohibited by the Sierra Leone legislation. This is particularly relevant to the dry mining operations as dewatering commences;
- An updated hydrocensus should be undertaken by SRL to confirm the location, groundwater levels and hydrochemistry of all groundwater extraction points within SR Area 1. Regular monitoring of these points should occur especially if they are likely to be affected by the mining operations. This should include yields, groundwater levels and qualities where possible;
- The extent of the Bullom sediments should be accurately mapped so that potential areas of greater groundwater ingress into the dry mining operations may be identified ahead of mining;
- An assessment of the pyrite or marcasite which may still be present in the ore below the groundwater surface should be undertaken since this may lead to acidification of the water pumped from the dry mining operations;
- A review of the mineral separation process should be undertaken to confirm that the majority of any high sulphide material from the dry mining operations can be removed for selective handling during rehabilitation to minimize any post mining impacts on water quality;
- An assessment of the sediment at the base of the historical mining ponds should be undertaken to determine if there are any significant sulphides contained there or not;
- Rehabilitation at Gangama will have to consider the extent of any saline intrusion and the impact that this may have on vegetation and the final land use in this area. The various options in this regard should be evaluated;
- Specialists should determine the appropriate management measures for the fuel storage tanks at Nitti Port;
- Additional piezometers should be installed to replace the vandalized piezometers that monitor the potential contamination sources at the MSP;
- The various mitigation measures that have been proposed in this report should be investigated further, and
- The proposed monitoring requirements in this report should be implemented.

## 18 ACKNOWLEDGEMENTS

The following SRL personnel offered invaluable assistance during the site visit, drilling, pump testing and subsequent assessment:

- John Barnes – Iluka Exploration Manager Africa;
- Shane Tilka – Chief Operating Officer;
- Ansu Jabati – Community & Rehabilitation Manager;
- Marcus Newlands – Environment, Health and Safety Manager;
- Mohamed Bawoh – Geology Manager;
- Solomon Tucker – Mine Planning Manager;
- Clovie Erasmus – Environmental & Radiation Superintendent;
- Geoff Taylor – Cranes and Rigging Superintendent;
- Mustapha Koroma – Geology Superintendent, and
- Clasina Roodt – Senior Environmental & Radiation Specialist.

The following external consultants greatly assisted in the coordination of the site visits, drilling and pump testing:

- Anneli Botha – Sustain Consulting Pty Ltd;
- Marius van Huyssteen – SRK Consulting (South Africa) (Pty) Ltd, and
- Paul Jorgensen – SRK Consulting (South Africa) (Pty) Ltd.

## 19 REFERENCES

- Button, M.T.G. (2011), *Geology of the Sierra Rutile Deposit*. Internal report Sierra Rutile Limited, 7p.
- DWAF & WRC (1995). *A South African Aquifer System Management Classification*. WRC Report No. KV77/95.
- Hede, A.R; Skovmand, B and López-Cesati (2001), *Acid Soils and Aluminum Toxicity*. In Reynolds, M.P., J.I. Ortiz-Monasterio, and A. McNab (eds.). *Application of Physiology in Wheat Breeding*. Mexico, D.F.: CIMMYT.
- Knight Piesold (2008), *Sierra Rutile Limited, Sierra Rutile Project Water Monitoring Report*. Report to Sierra Rutile Limited, Project DV-301/0017.03, 30p.
- NEPAD (2005), *Bankable Investment Project Profile - Freetown Fisheries Harbour Complex*. Volume III of IV, NEPAD Ref. 05/23 E, 31p.
- Parsons, R.P, (1995): *A South African Aquifer System Management Classification*. WRC Report No. KV 77/95, Water Research Commission, Pretoria.
- Republic of Sierra Leone (2002), *Sierra Rutile Agreement (Ratification Act)*
- Republic of Sierra Leone (2008), *The Environment Protection Agency Act, 2008*. Act No. 11 of 2008. Supplement to the Sierra Leone Gazette Vol. CXXXIX, No. 44.
- Republic of Sierra Leone (2009), *The Mine and Minerals Act, 2009*. Act No. 12 of 2009. Supplement to the Sierra Leone Gazette Vol. CXLI, No. 3.
- Republic of Sierra Leone (2013), *The Environment Protection (Mines and Minerals) Regulations, 2013*.
- SRK (2013), *Site Visit Report*. Memo to Sierra Rutile Limited, Project No. 450300\_Water, 20p.
- SRK (2013), *Water Quality Monitoring Protocol for Sierra Rutile Mine*. Report to Sierra Rutile Limited, Report No. Report Number 450300/Water Monitoring Protocol, 35p.
- SRK (2017), *Personal Communication*.
- SRK (2018), *Sierra Rutile Project Area 1 – Environmental, Social and Health Impact Assessment: Surface Water Specialist Study*. Report to Sierra Rutile Limited, Report No: 515234/ D1 Surface Water, 161p.
- SRK (2018), *Sierra Rutile Project Area 1 – Environmental, Social and Health Impact Assessment: Mine Closure Plan*. Report to Sierra Rutile Limited, Report No: 515234 Mine Closure Plan, 71p.
- SRK (2017), *Sierra Rutile Project Area 1 – Environmental, Social and Health Impact Assessment: Geochemistry Characterisation of Selected Residues*. Draft Report to Sierra Rutile Limited, Report No.: 515234/ Geochemistry, 48p.
- SRL (2017), *Personal Communication*.

WHO (2007), *pH in Drinking-water - Revised background document for development of WHO Guidelines for Drinking-water Quality*. Ref WHO/SDE/WSH/07.01/1 8p.

WHO (2017), *Guidelines for drinking-water quality: fourth edition incorporating the first addendum*. Geneva. ISBN 978-92-4-154995-0, 541p.



## **APPENDIX A: BOREHOLE LOGS**

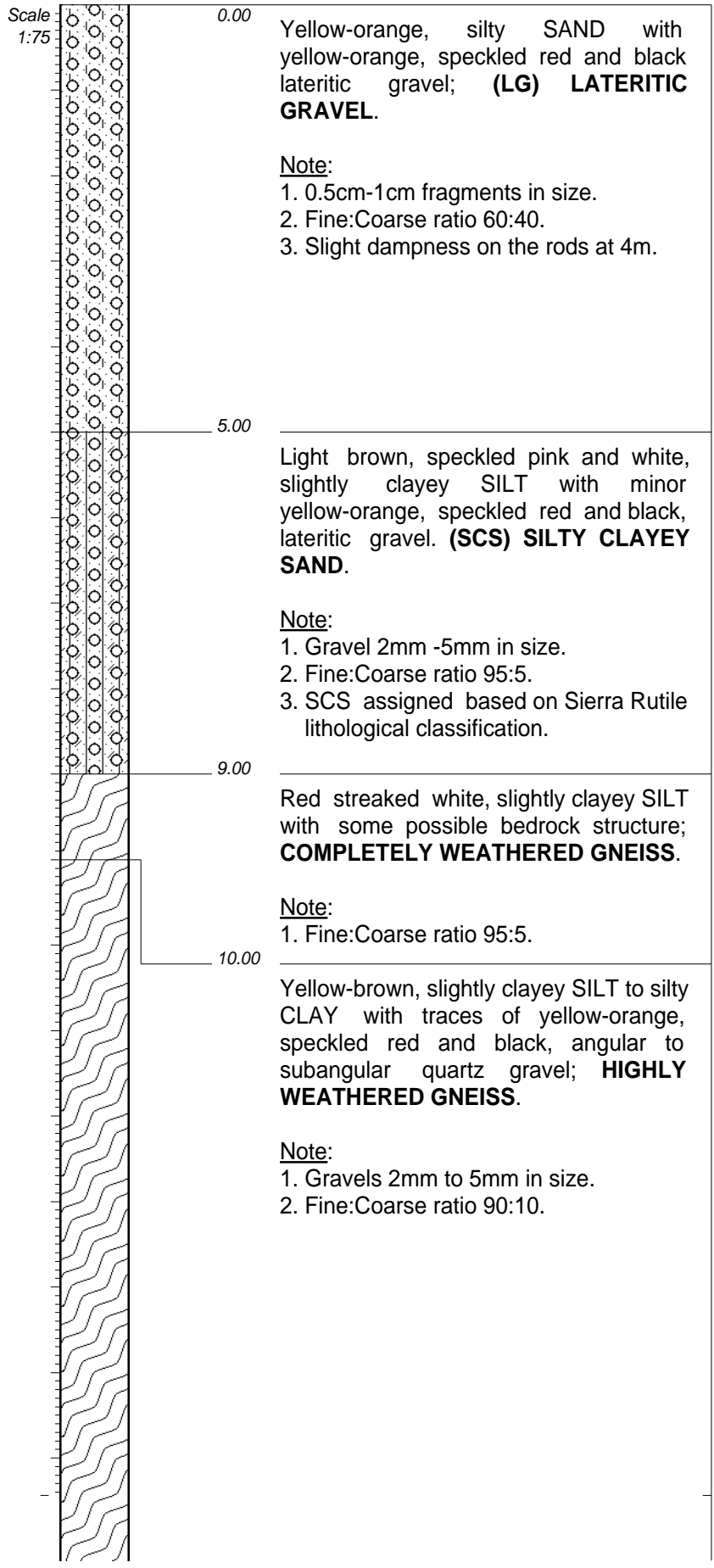
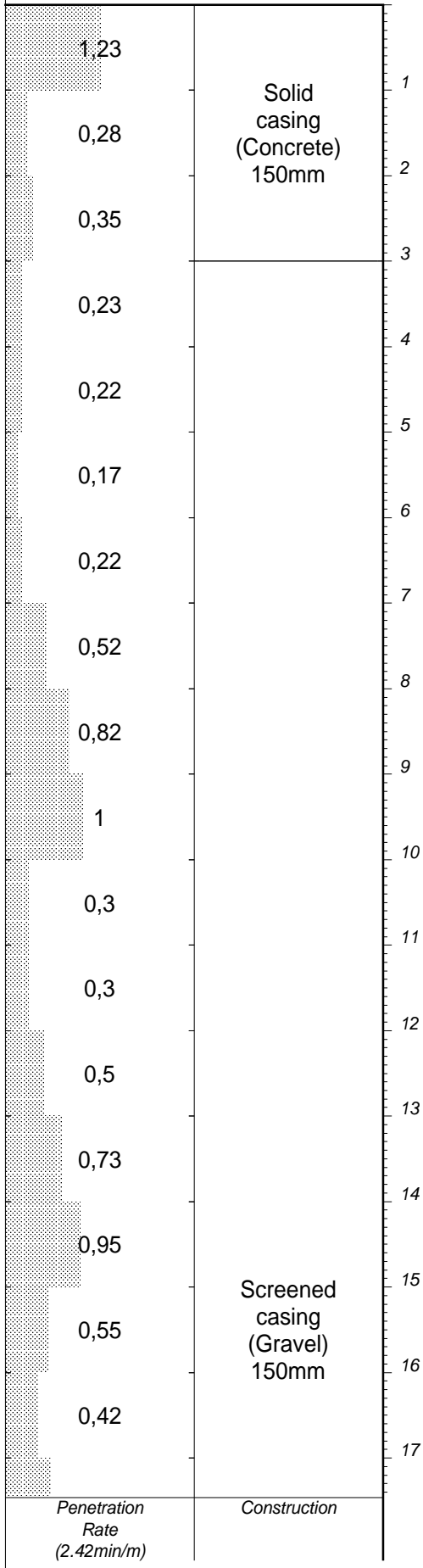
## **APPENDIX A: BOREHOLE LOGS**



SIERRA RUTILE LTD.  
GROUND WATER MONITORING WELLS  
SR AREA 1

HOLE No: SRL17/01  
Sheet 1 of 2

JOB NUMBER: 0

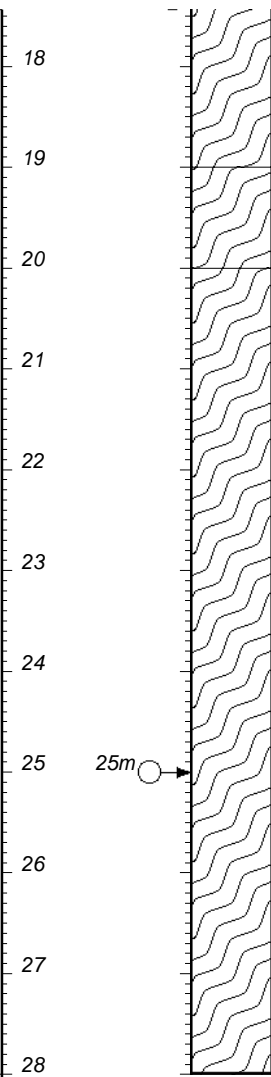
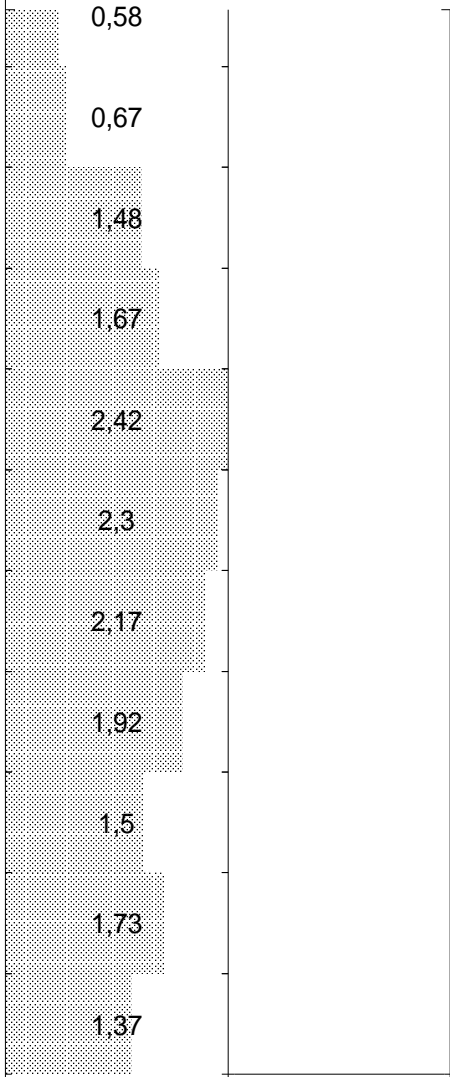




SIERRA RUTILE LTD.  
GROUND WATER MONITORING WELLS  
SR AREA 1

HOLE No: SRL17/01  
Sheet 2 of 2

JOB NUMBER: 0



19.00  
Dark olive-green SILT with abundant angular, dark grey to black, moderately to slightly weathered gneiss fragments; **MODERATELY TO SLIGHTLY WEATHERED GNEISS BEDROCK.**

NOTE:  
1. Fragments 2mm to 1cm in size.  
2. Fine:Coarse ratio 70:30.

20.00  
Dark grey-green to black, angular gneiss with abundant dark red garnet; **FRESH GNEISS.**

Note:  
1. Fragments 2mm to 1cm in size possibly fractured.  
2. Water strike at 25m.

25m

- 28.00
- NOTES**
- 1) Water strike at 25m.
  - 2) Solid casing 0m-3m.
  - 3) Screened casing 3m-28m.
  - 4) Blow yield 0.72l/sec.

--	--

Penetration Rate (2.42min/m)	Construction
---------------------------------	--------------

CONTRACTOR : Edal Drilling Company Ltd.  
MACHINE :  
DRILLED BY :  
PROFILED BY : RK  
TYPE SET BY :  
SETUP FILE : STANDARD.SET

INCLINATION : Vertical  
DIAM :  
DATE : 17 October 2017  
DATE : 17 October 2017  
DATE : 16/02/2018 10:31  
TEXT : ..LVFINALSIERRALOGSALL.DOC

ELEVATION : 59m  
X-COORD : 802009  
Y-COORD : 867469

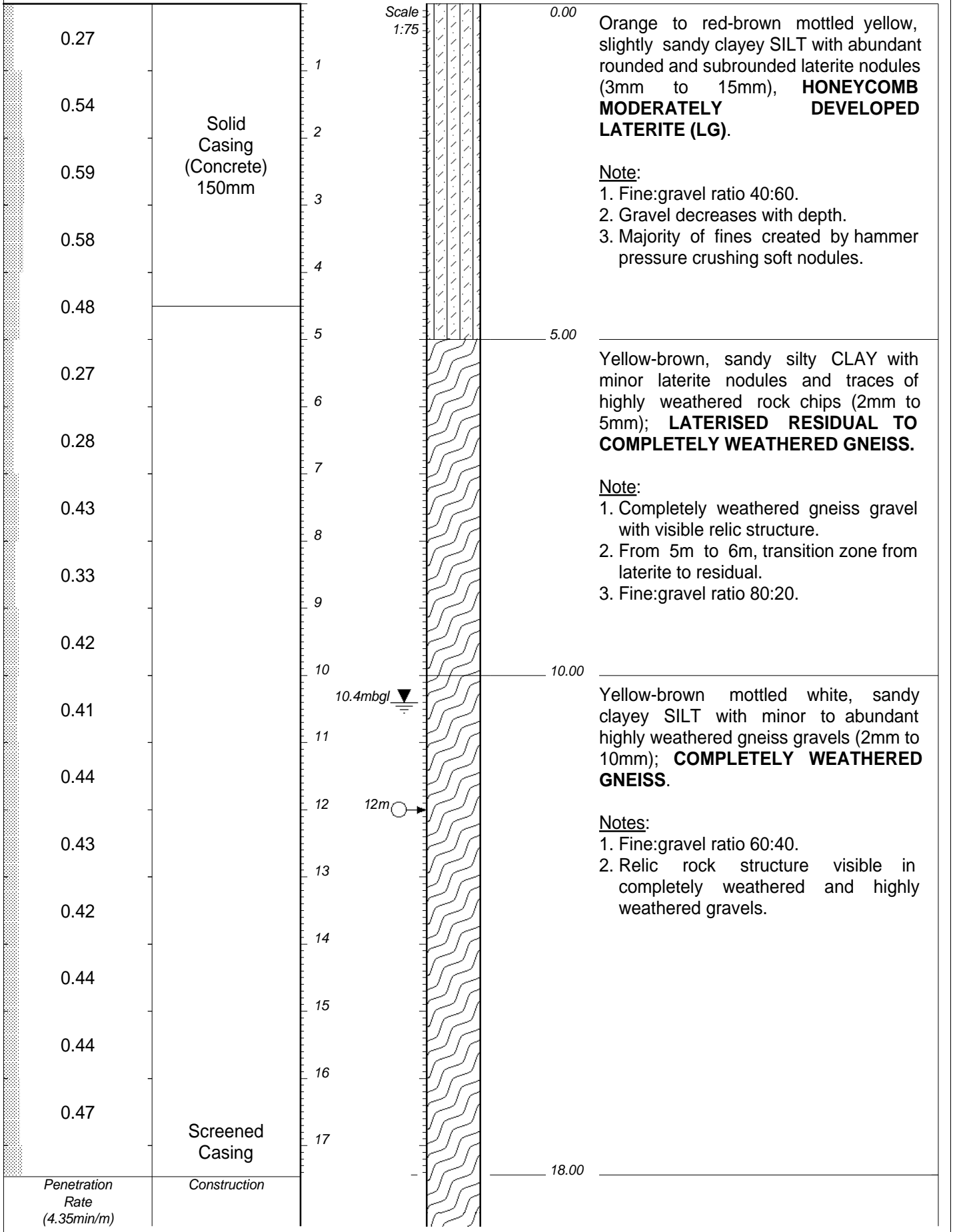
HOLE No: SRL17/01



SIERRA RUTILE LTD.  
GROUND WATER MONITORING WELLS  
SR AREA 1

HOLE No: SRL17-02  
Sheet 1 of 2

JOB NUMBER: 0

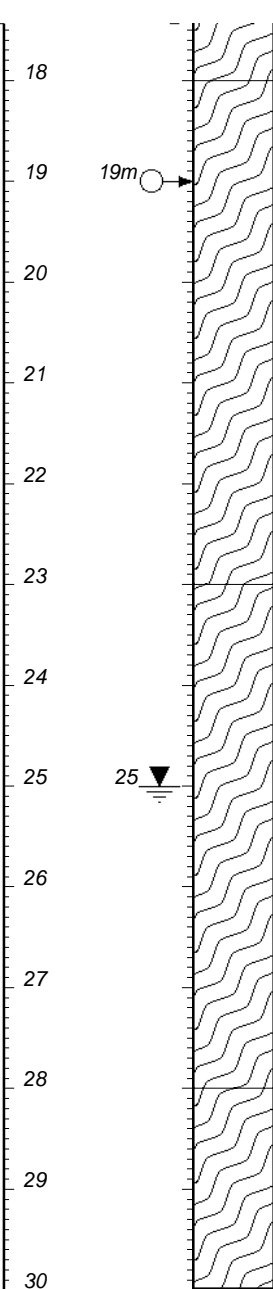
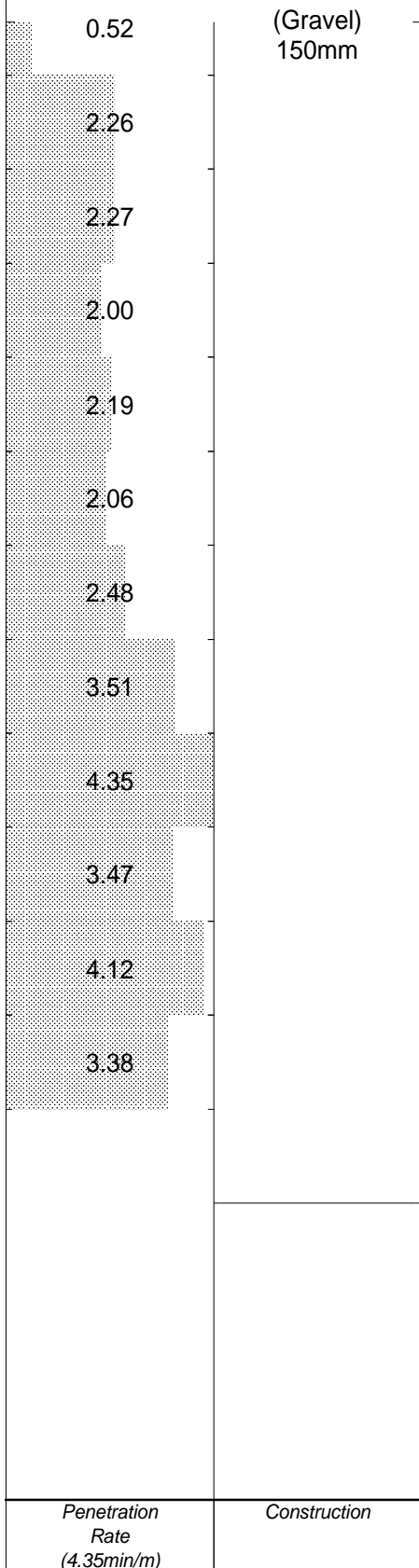




SIERRA RUTILE LTD.  
GROUND WATER MONITORING WELLS  
SR AREA 1

HOLE No: SRL17-02  
Sheet 2 of 2

JOB NUMBER: 0



Grey mottled brown, silty SAND with abundant medium weathered to slightly weathered gravel gneiss (2mm to 4mm) and minor highly weathered gneiss gravel (2mm to 5mm), possibly highly fractured and jointed; **MODERATELY WEATHERED GNEISS.**

Note:  
1. From 18m to 19m, transition from highly weathered to moderately weathered gneiss.  
2. Fine:gravel ratio 80:20. Majority of fines are possibly created by drilling.

White streaked black speckled red, moderately weathered, highly fractured and closely jointed with staining and weathering on chip surface, **GARNET GNEISS.**

Note:  
1. Chip sizes 50-70mm.

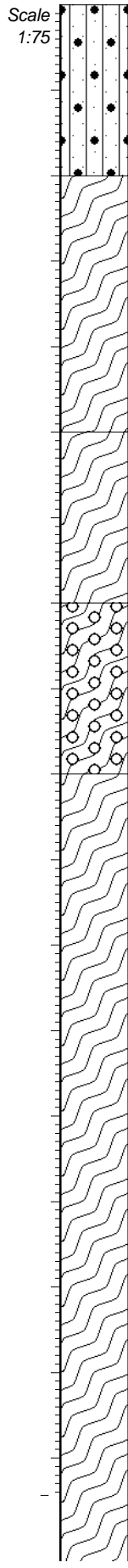
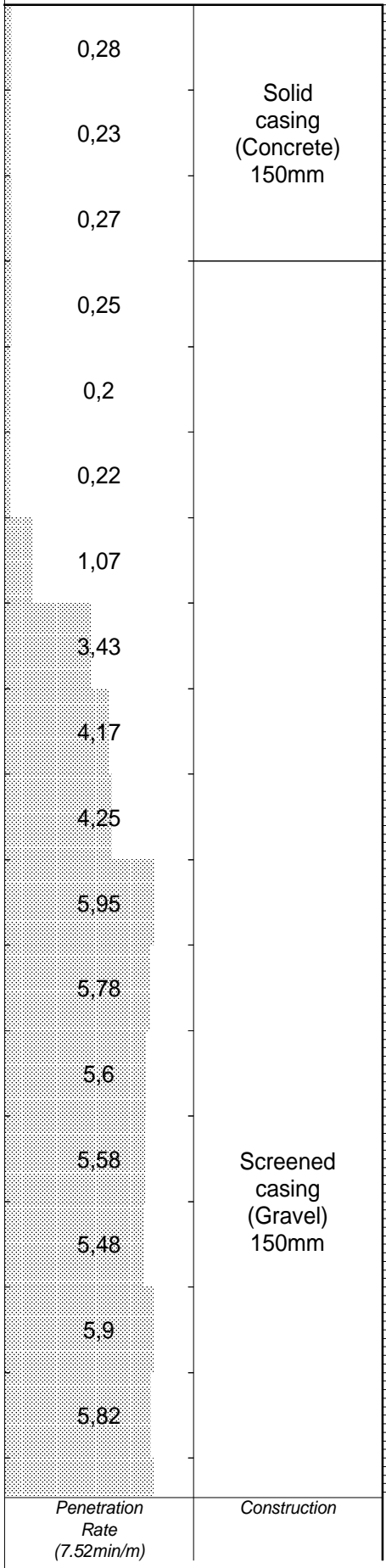
Grey, white, translucent, red, **SLIGHTLY WEATHERED GARNET GNEISS**, most likely no fractures and jointing.

Note:  
1. Chips of 1mm to 2mm and drill dust of pulverized rock.

- NOTES**
- 1) Plain casing +0.5magl to 4.5mbgl (150mm). Concrete from 0m to approximately 3m.
  - 2) Screened casing 4.5mbgl to 30mbgl = gravel approximately 3m to 30m.
  - 3) Water seepage encountered at 12m.
  - 4) Water strike at 19m.
  - 5) Blow yield 4l/sec.
  - 6) Dip water level at 10.4mbgl on 25 September 2017.

CONTRACTOR : Edal Drilling Co. Ltd.	INCLINATION : Vertical	ELEVATION : 52m
MACHINE :	DIAM :	X-COORD : 0861180
DRILLED BY :	DATE : 18 August 2017	Y-COORD : 0801595
PROFILED BY : MvR	DATE : 23 September 2017	
TYPE SET BY :	DATE : 16/02/2018 10:31	
SETUP FILE : STANDARD.SET	TEXT : ..L\FINALSIERRALOGSALL.DOC	

HOLE No: SRL17-02



0.00 Reddish brown, slightly clayey sandy SILT with abundant angular to subangular lateritic gravel. Possible hardpan laterite; **(BL) BLOCKY LATERITE.**

1. Fragments 2mm to 2cm in size.  
2. Fine:Coarse ratio 60:40.

---

2.00 Yellow-brown, sandy SILT with highly weathered gneissic and lateritic fragments; **HIGHLY WEATHERED GNEISS.**

Note:  
1. Fragments 2mm to 2cm in size.  
2. Fine:Coarse ratio 40:60.

---

5.00 Yellow-brown, moderately weathered, gneissic fragments with abundant slightly weathered, dark green to black speckled white, GNEISS; **MODERATELY TO SLIGHTLY WEATHERED GNEISS.**

Note:  
1. Moderately weathered 1mm-1cm, slightly weathered gneiss chips 1mm-3cm.  
2. Fine:Coarse ratio 30:70.

---

7.00 Highly jointed, dark green to black, angular to subangular, bedrock gravel with minor silt; **FRACTURED GNEISS.**

Note:  
1. Fragment sizes 2cm-5cm.  
2. Fine :Coarse ratio 10:90.  
3. No evidence of water.

---

9.00 Massive grey to black speckled white GNEISS with translucent quartz and light pink fragments below 11m; **FRESH GNEISS.**

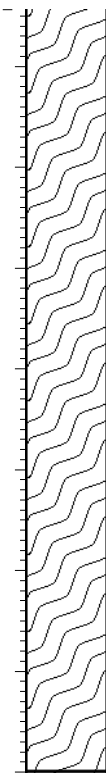
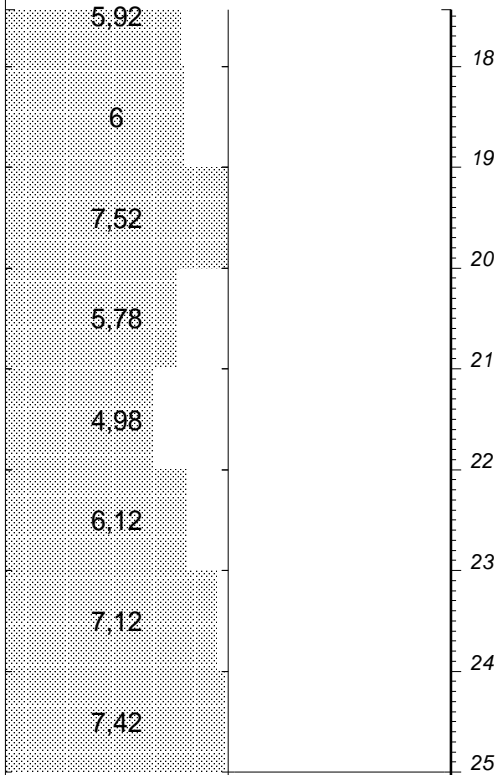
Note:  
1. Chips 1mm to 1cm.



SIERRA RUTILE LTD.  
GROUND WATER MONITORING WELLS  
SR AREA 1

HOLE No: **SRL017/03**  
Sheet 2 of 2

JOB NUMBER: 0



25.00

NOTES

- 1) Slight seepage at 22m.
- 2) Solid casing 0m-3m.
- 3) Screened casing 3m-25m.
- 4) No Blow yield due to low seepage.

Penetration Rate (7.52min/m)	Construction
---------------------------------	--------------

CONTRACTOR : Edal Drilling Company Ltd.

MACHINE :  
DRILLED BY :  
PROFILED BY : RK

TYPE SET BY :  
SETUP FILE : STANDARD.SET

INCLINATION : Vertical

DIAM :  
DATE : 5 October 2017  
DATE : 6 October 2017

DATE : 16/02/2018 10:31  
TEXT : ..LVFINALSIERRALOGSALL.DOC

ELEVATION : 56m  
X-COORD : 805814  
Y-COORD : 858139

HOLE No: **SRL017/03**

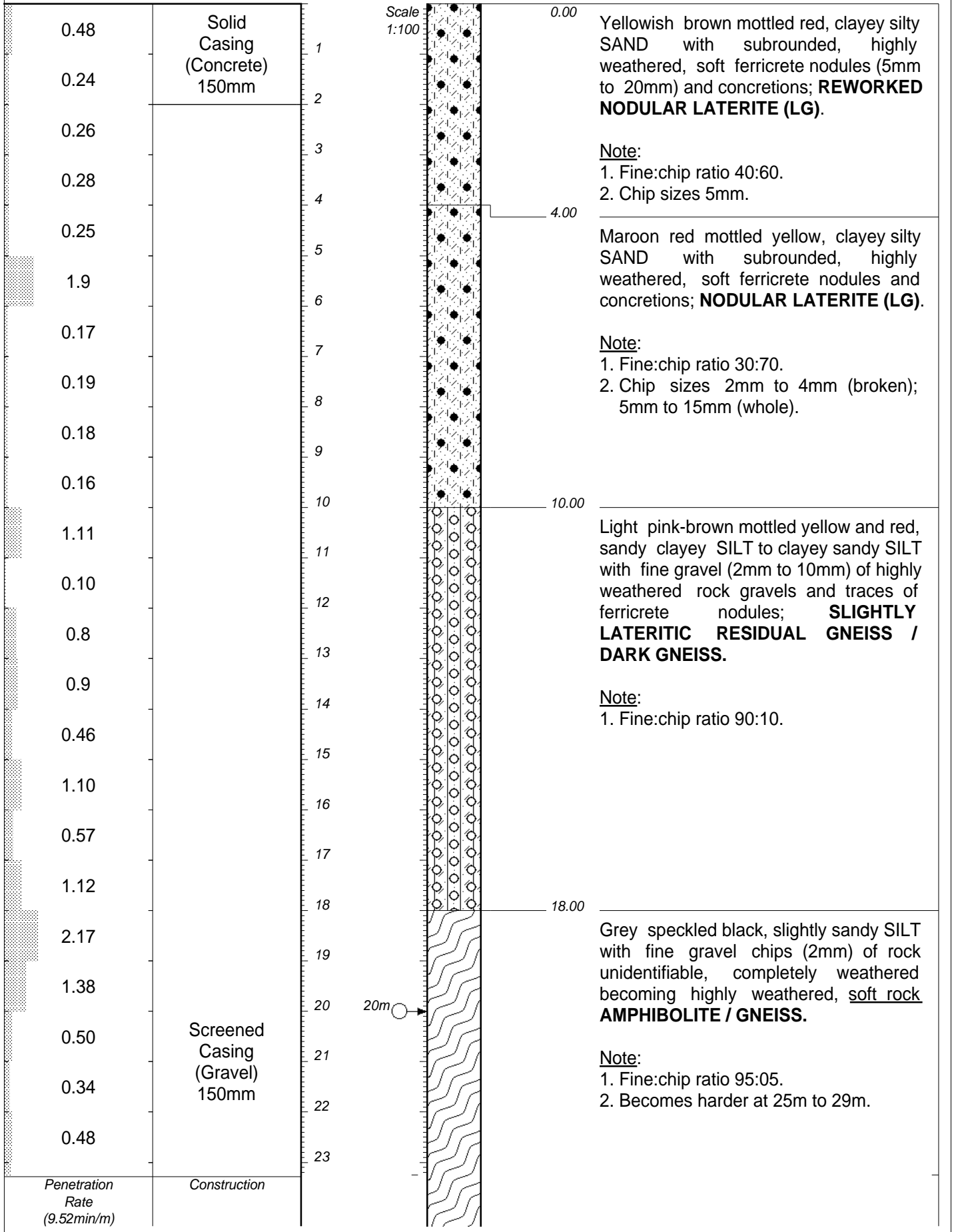




SIERRA RUTILE LTD.  
GROUND WATER MONITORING WELLS  
SR AREA 1

HOLE No: SRL17-04  
Sheet 1 of 2

JOB NUMBER: 0

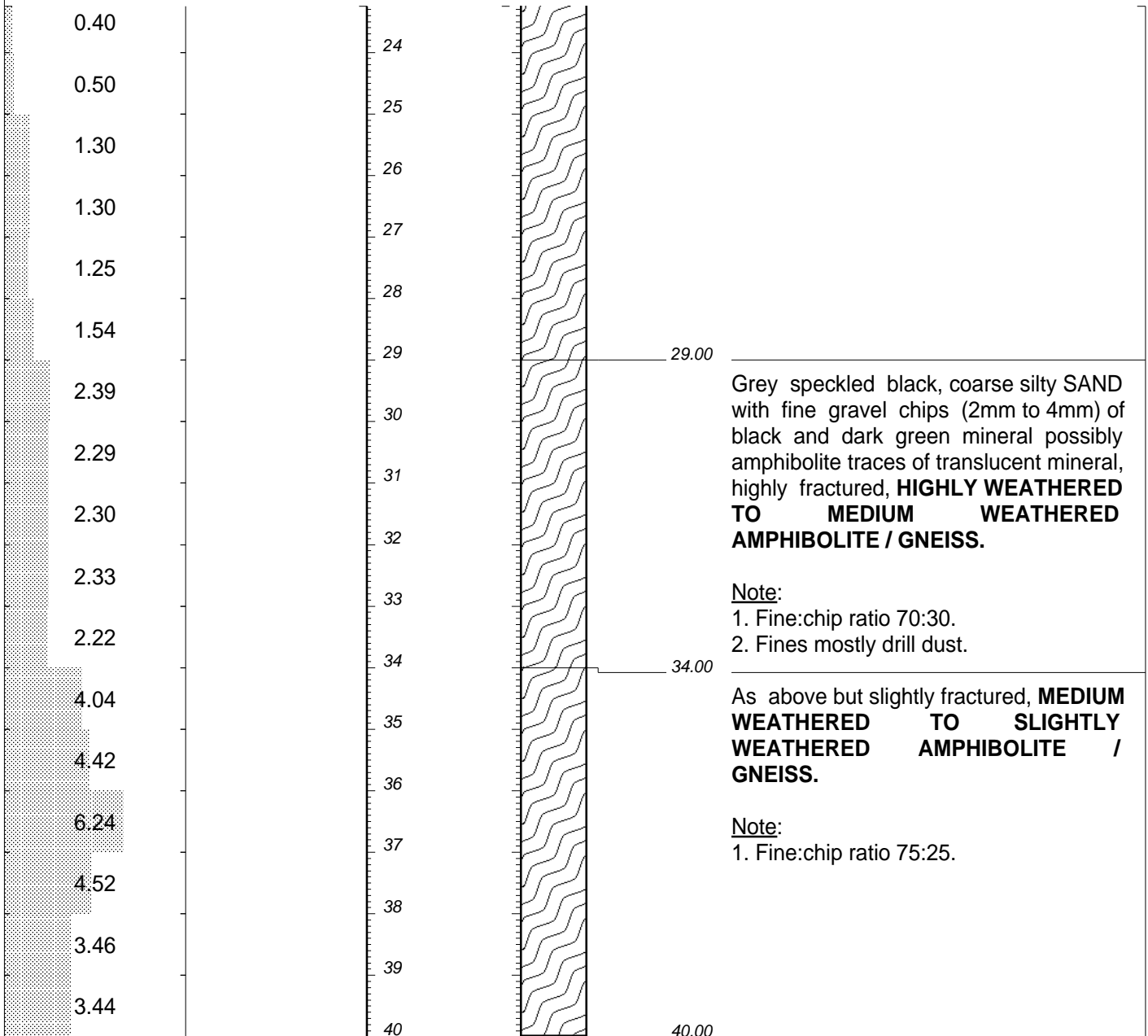




SIERRA RUTILE LTD.  
GROUND WATER MONITORING WELLS  
SR AREA 1

HOLE No: SRL17-04  
Sheet 2 of 2

JOB NUMBER: 0



Penetration Rate (9.52min/m)	Construction

- NOTES
- 1) Water strike at approximately 20m.
  - 2) Solid casing approximately 0-2m.
  - 3) Screened casing 2m-40m.
  - 4) Date drilled 18 September 2017.

CONTRACTOR : Edal Drilling Co. Ltd.  
MACHINE :  
DRILLED BY :  
PROFILED BY : MvR  
TYPE SET BY :  
SETUP FILE : STANDARD.SET

INCLINATION : Vertical  
DIAM :  
DATE : 18 September 2017  
DATE : 23 September 2017  
DATE : 16/02/2018 10:31  
TEXT : ..LVFINALSIERRALOGSALL.DOC

ELEVATION : 46m  
X-COORD : 0854242  
Y-COORD : 0804557

HOLE No: SRL17-04

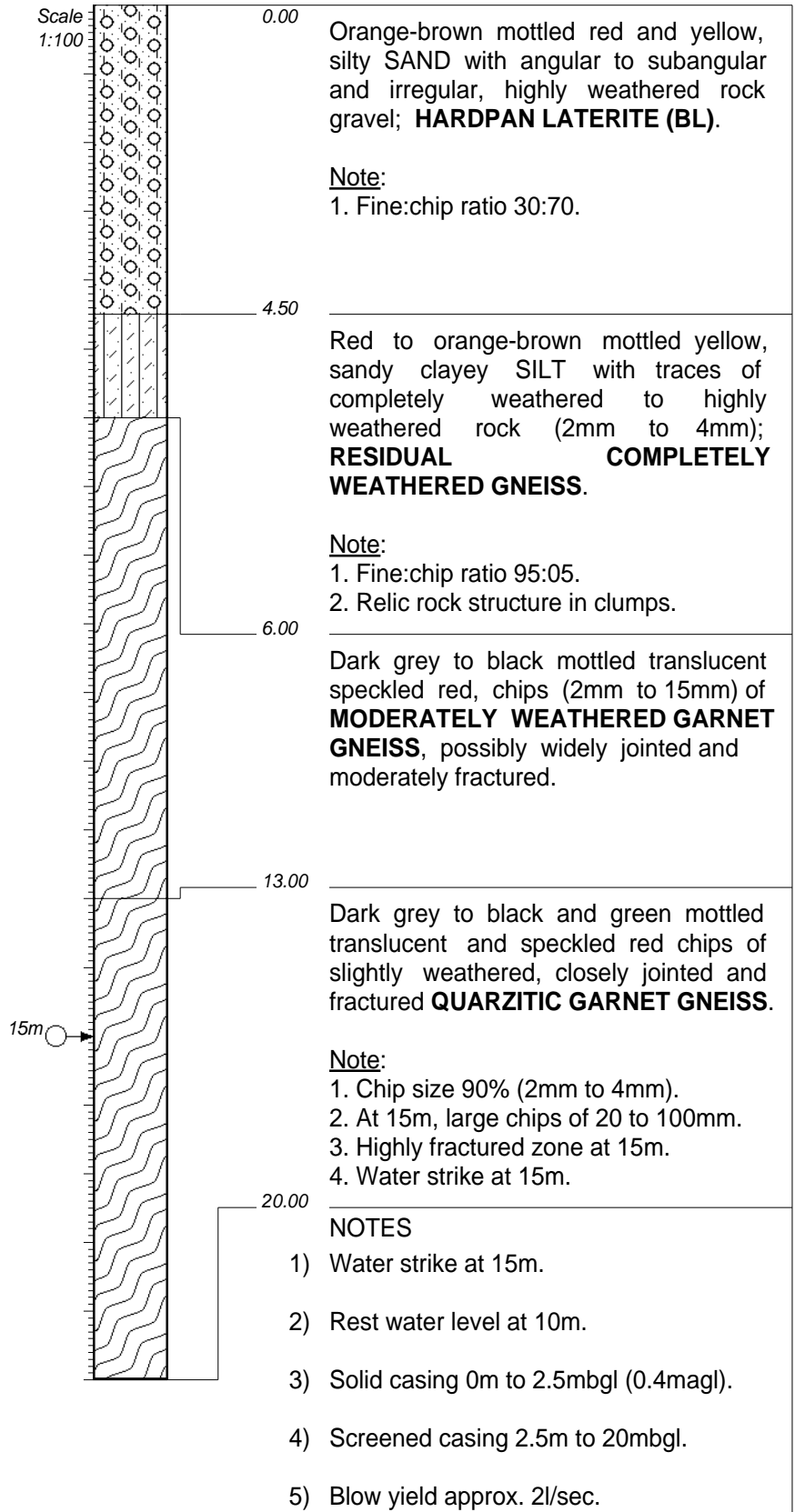


SIERRA RUTILE LTD.  
GROUND WATER MONITORING WELLS  
SR AREA 1

HOLE No: SRL17-05  
Sheet 1 of 1

JOB NUMBER: 0

1.00	Solid casing (Concrete) 150mm	1
1.03		2
1.04		3
1.00	Screened casing (Gravel) 150mm	4
0.55		5
0.30		6
0.38		7
3.28		8
4.02		9
4.33		10
5.01		11
5.00		12
5.02		13
5.05		14
5.00		15
6.24		16
6.25		17
6.30		18
6.33		19
6.44		20
Penetration Rate (6.44min/m)	Construction	



CONTRACTOR : Edal Drilling Co. Ltd.

MACHINE :  
DRILLED BY :  
PROFILED BY : MvR

TYPE SET BY :  
SETUP FILE : STANDARD.SET

INCLINATION :

DIAM :  
DATE : 3 October 2017  
DATE : 3 October 2017

DATE : 16/02/2018 10:31  
TEXT : ..L\FINALSIERRALOGSALL.DOC

ELEVATION : 51m

X-COORD : 0801426  
Y-COORD : 0852866

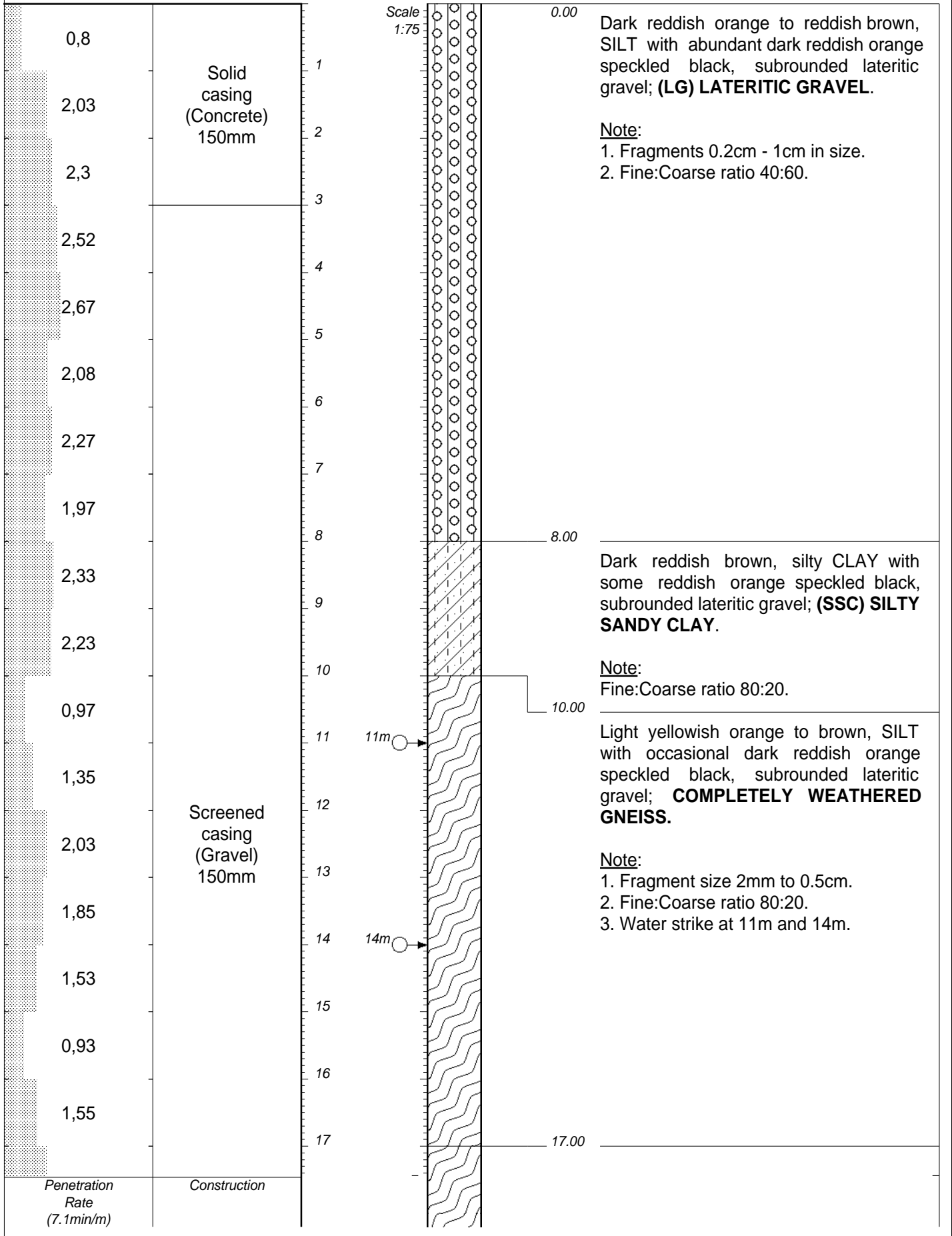
HOLE No: SRL17-05



SIERRA RUTILE LTD.  
GROUND WATER MONITORING WELLS  
SR AREA 1

HOLE No: SRL17/06  
Sheet 1 of 2

JOB NUMBER: 0

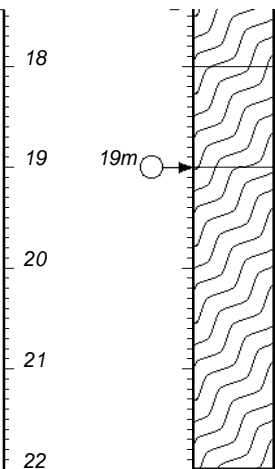
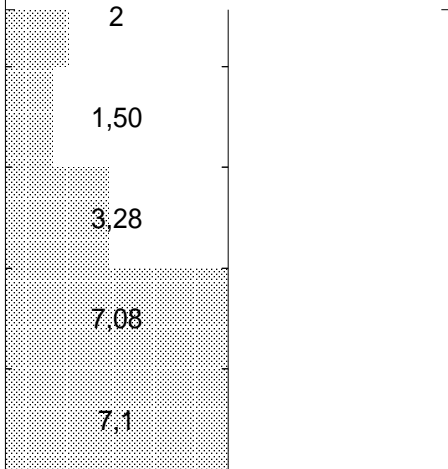




SIERRA RUTILE LTD.  
GROUND WATER MONITORING WELLS  
SR AREA 1

HOLE No: SRL17/06  
Sheet 2 of 2

JOB NUMBER: 0



Light brown, yellow-orange streaked red, SILT with abundant white to beige speckled black, subangular gneissic fragments; **MODERATELY WEATHERED GNEISS.**

Note:  
1. Fragments 2mm to 3cm in size.  
2. Fine:Coarse ratio 60:40.

White to beige speckled black, slightly weathered to highly fractured, angular GNEISS; **SLIGHTLY WEATHERED TO FRACTURED GNEISS.**

Note:  
1. Fragments up to 7cm.  
2. Good water strike at 19m.

White to grey-green, speckled black and red, fresh GNEISS. **FRESH GNEISS.**

Note:  
1. Fragments 1mm - 1cm in size.

NOTES

- 1) Water strike at 11m and 14m. Good water strike at 19m.
- 2) Solid casing 0m-3m.
- 3) Screened casing 3m-22m.
- 4) Blow yield 20l/sec.

Penetration Rate (7.1min/m)	Construction
--------------------------------	--------------

CONTRACTOR : Edal Drilling Company Ltd.  
MACHINE :  
DRILLED BY :  
PROFILED BY : RK  
TYPE SET BY :  
SETUP FILE : STANDARD.SET

INCLINATION : Vertical  
DIAM :  
DATE : 24 October 2017  
DATE : 24 October 2017  
DATE : 16/02/2018 10:31  
TEXT : ..L\FINALSIERRALOGSALL.DOC

ELEVATION : 20m  
X-COORD : 798398  
Y-COORD : 859191

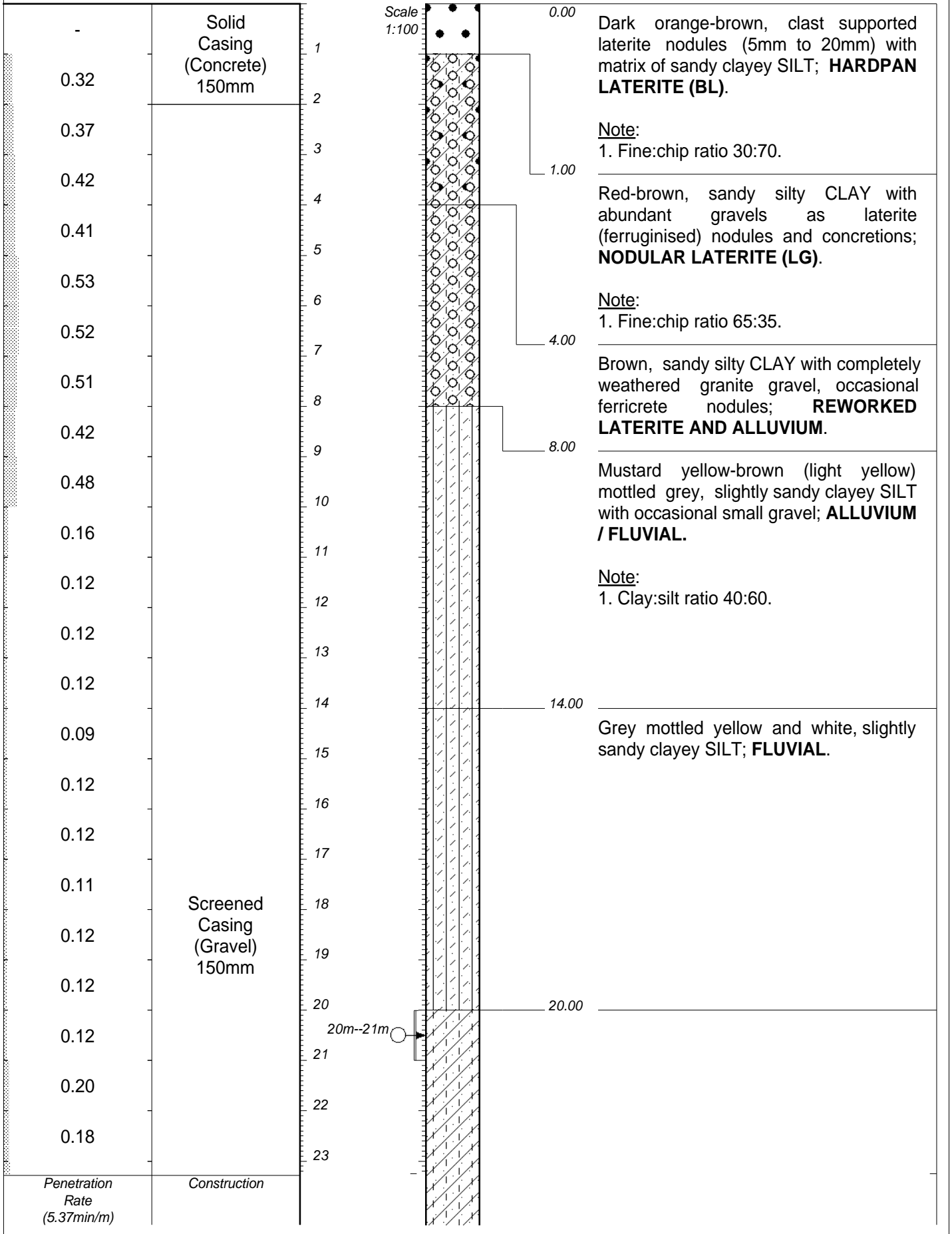
HOLE No: SRL17/06



SIERRA RUTILE LTD.  
GROUND WATER MONITORING WELLS  
SR AREA 1

HOLE No: SRL17-07  
Sheet 1 of 2

JOB NUMBER: 0

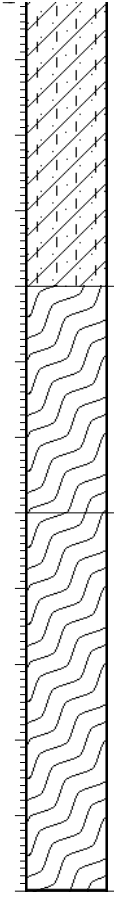
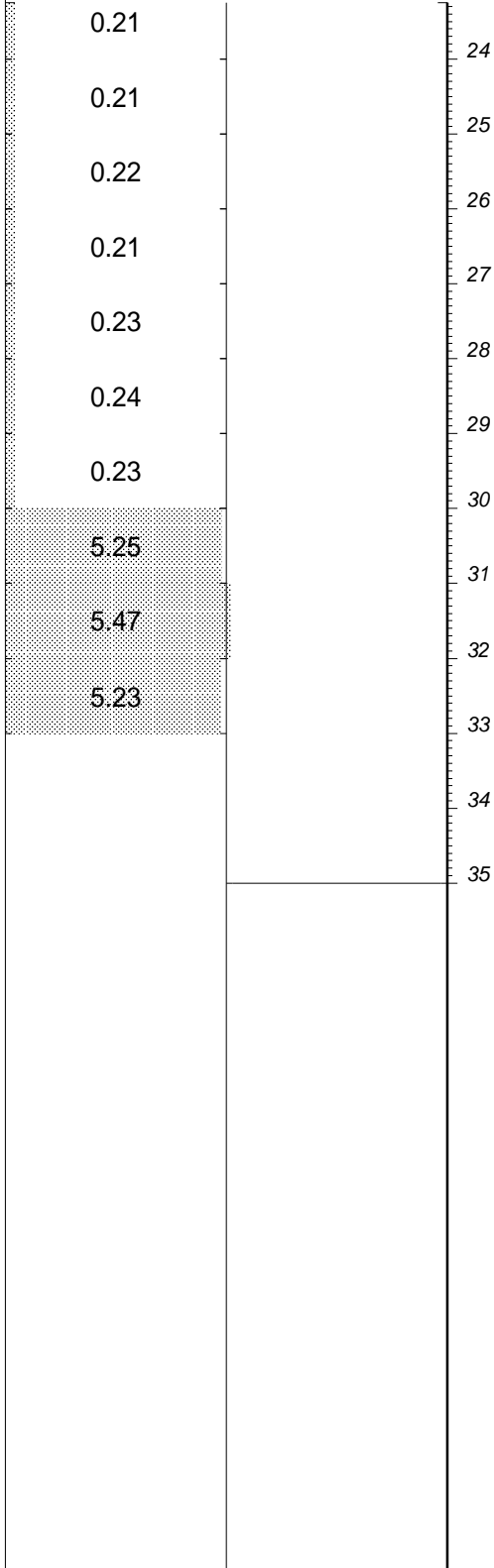




SIERRA RUTILE LTD.  
GROUND WATER MONITORING WELLS  
SR AREA 1

HOLE No: **SRL17-07**  
Sheet 2 of 2

JOB NUMBER: 0



Grey speckled black silty sandy CLAY with occasional pulverized small gravel;  
**RESIDUAL GNEISS**

Note:  
1. Poor sample return from 25m to 27m.

27.00  
Light grey to grey speckled black, highly weathered gneiss gravel (5mm to 50mm) with rutile inclusions in clayey silty SAND matrix; completely weathered, soft rock  
**RUTILE GNEISS.**

Note:  
1. Majority of sample is silty sand.  
2. Weathered rock mostly pulverized.  
3. Rock samples retrieved when hole was blown.

30.00  
White and green speckled light pink, fine to medium coarse, slightly weathered to fresh gravel (approximately 10mm);  
**DARK GNEISS ROCK.**

Note:  
1. Poor sample return - temporary casing broke flushing sample out the side.

35.00

- NOTES**
- 1) Blow yield 5 l/sec.
  - 2) Plain casing 0m to approximately 2m.
  - 3) Screened casing from approximately 2m to 35m.
  - 4) Water strike at 20m--21m.

Penetration Rate (5.37min/m)	Construction
---------------------------------	--------------

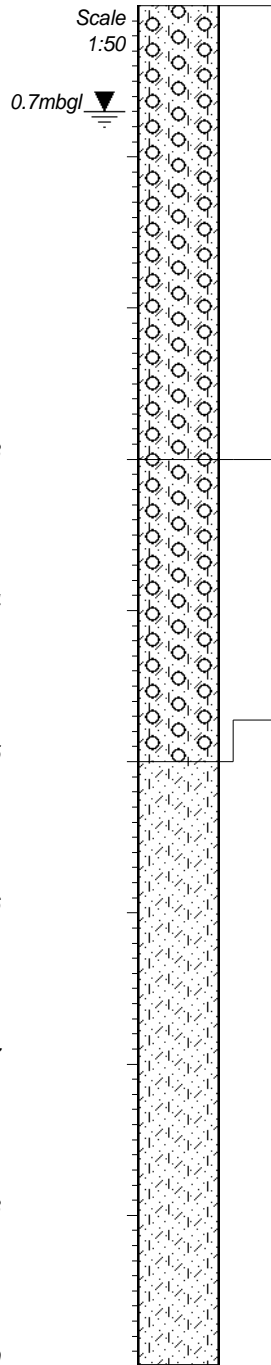
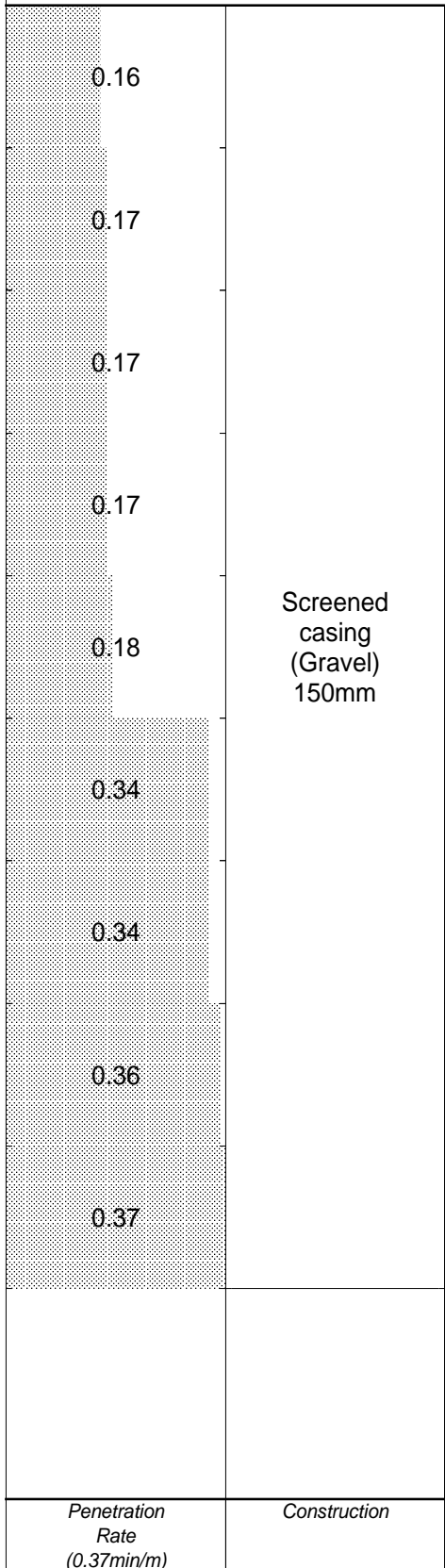
CONTRACTOR : Edal Drilling Co. Ltd.	INCLINATION : Vertical	ELEVATION :
MACHINE :	DIAM :	X-COORD :
DRILLED BY :	DATE : 4 August 2017	Y-COORD :
PROFILED BY : MvR	DATE : 23 September 2017	
TYPE SET BY :	DATE : 16/02/2018 10:31	<b>HOLE No: SRL17-07</b>
SETUP FILE : STANDARD.SET	TEXT : ..L\FINALSIERRALOGSALL.DOC	



SIERRA RUTILE LTD.  
GROUND WATER MONITORING WELLS  
SR AREA 1

HOLE No: SRL17-08A  
Sheet 1 of 1

JOB NUMBER: 0



0.00 Mixed red, light pink and white, clayey silty SAND with quartz and mixed gravel chips (2mm to 4mm); **ORE BODY (SCS) SILTY CLAYEY SAND.**

Note:  
1. Fine:chip ratio 80:20.

3.00 Dark grey, silty clayey SAND to clayey silty SAND with subangular translucent white and grey quartz gravels (2mm to 20mm). Metallic lustre on some large quartz gravels, scattered pyrite chips 1mm; **ORE BODY (SCS) SILTY CLAYEY SAND.**

5.00 Grey mottled light grey to orange, clayey silty SAND becoming silty clayey SAND with depth. Chips of subangular irregular quartz gravel and scattered subrounded (2mm to 20mm) traces of highly weathered rock and scattered pyrite chips (1mm to 2mm); **(SCS) SILTY CLAYEY SAND.**

Note:  
1. Fine:chip ratio 80:20.

- 9.00
- NOTES**
- Hole stopped.
  - Screened casing 0m to 9m.
  - No water strike.
  - Slow recharge / water present after time.
  - Borehole pair to SRL17/08B drilled into bedrock 20m away.
  - Dip water level at 0.7mbgl on 25 September 2017.
  - No blow yield done, water recovery too slow.

CONTRACTOR : Edal Drilling Co. Ltd.	INCLINATION : Vertical	ELEVATION : 20m
MACHINE :	DIAM :	X-COORD : 0795886
DRILLED BY :	DATE : 23 September 2017	Y-COORD : 0850511
PROFILED BY : MvR	DATE : 23 September 2017	
TYPE SET BY :	DATE : 16/02/2018 10:31	HOLE No: SRL17-08A
SETUP FILE : STANDARD.SET	TEXT : ..\FINALSIERRALOGSALL.DOC	

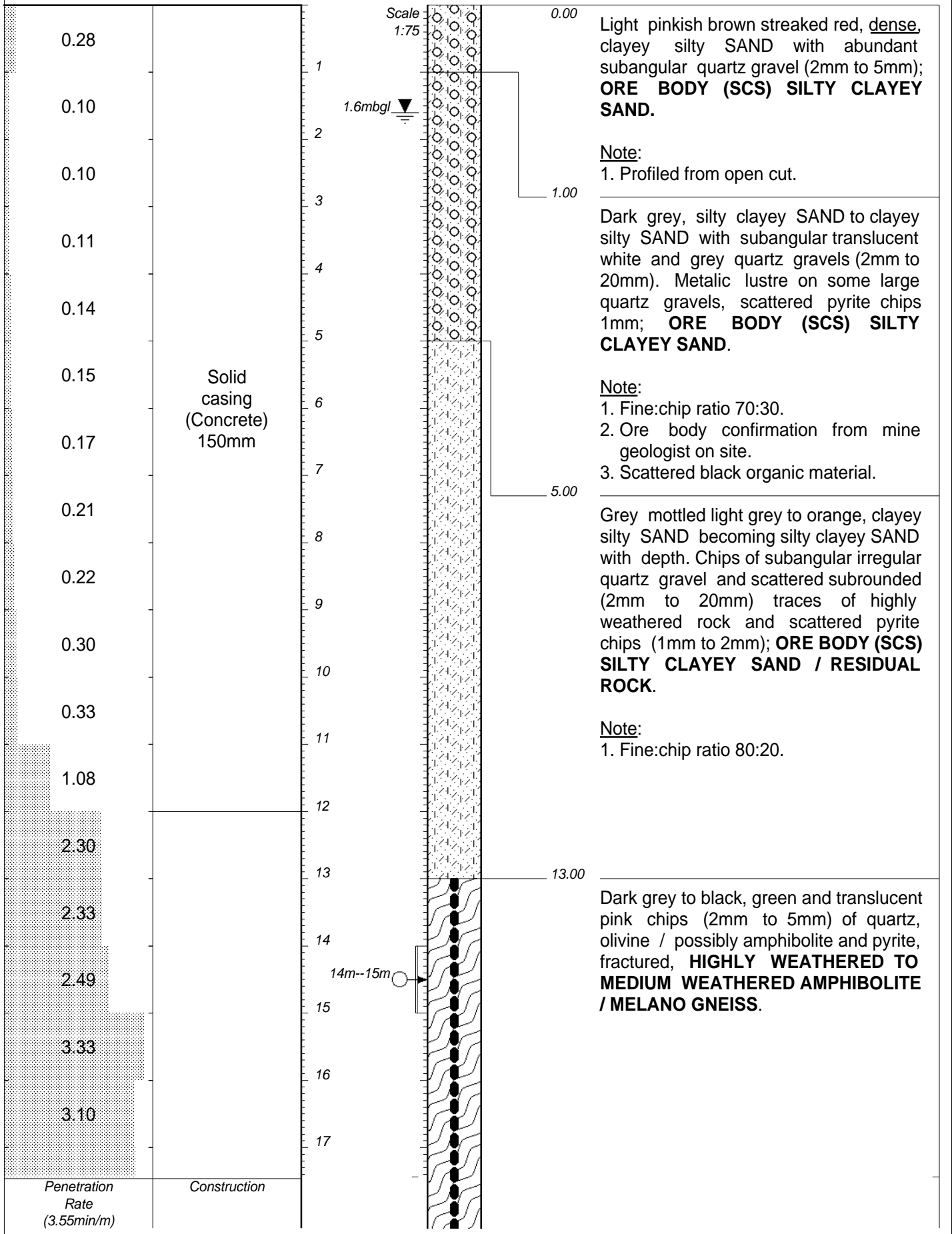




SIERRA RUTILE LTD.  
GROUND WATER MONITORING WELLS  
SR AREA 1

HOLE No: SRL17-08B  
Sheet 1 of 2

JOB NUMBER: 0



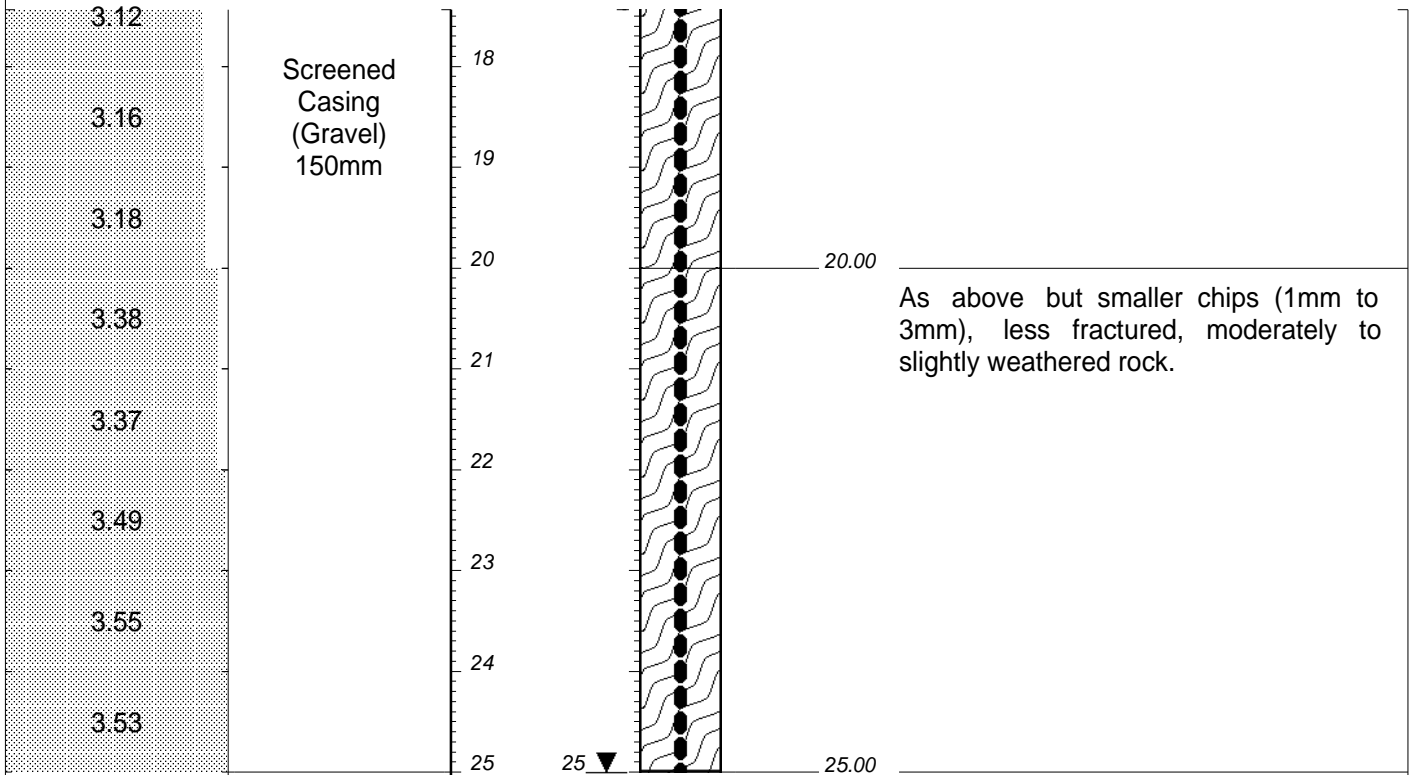


SIERRA RUTILE LTD.  
GROUND WATER MONITORING WELLS  
SR AREA 1

HOLE No: **SRL17-08B**

Sheet 2 of 2

JOB NUMBER: 0



NOTES

- 1) Small water strike at 14m--15m.
- 2) Solid casing 0m to 12m.
- 3) Screened casing 12m to 25m.
- 4) Part of a borehole pair with SRL17/08A, 20m away.
- 5) Dip water level at 1.6mbgl on 25 September 2017.
- 6) Blow yield 1.5l/sec.

Penetration Rate  
(3.55min/m)

Construction

CONTRACTOR : Edal Drilling Co. Ltd.

MACHINE :  
DRILLED BY :  
PROFILED BY : MvR

TYPE SET BY :  
SETUP FILE : STANDARD.SET

INCLINATION : Vertical

DIAM :  
DATE : 22 September 2017  
DATE : 23 September 2017

DATE : 16/02/2018 10:31  
TEXT : ..LVFINALSIERRALOGSALL.DOC

ELEVATION : 15m

X-COORD : 0795887  
Y-COORD : 0850536

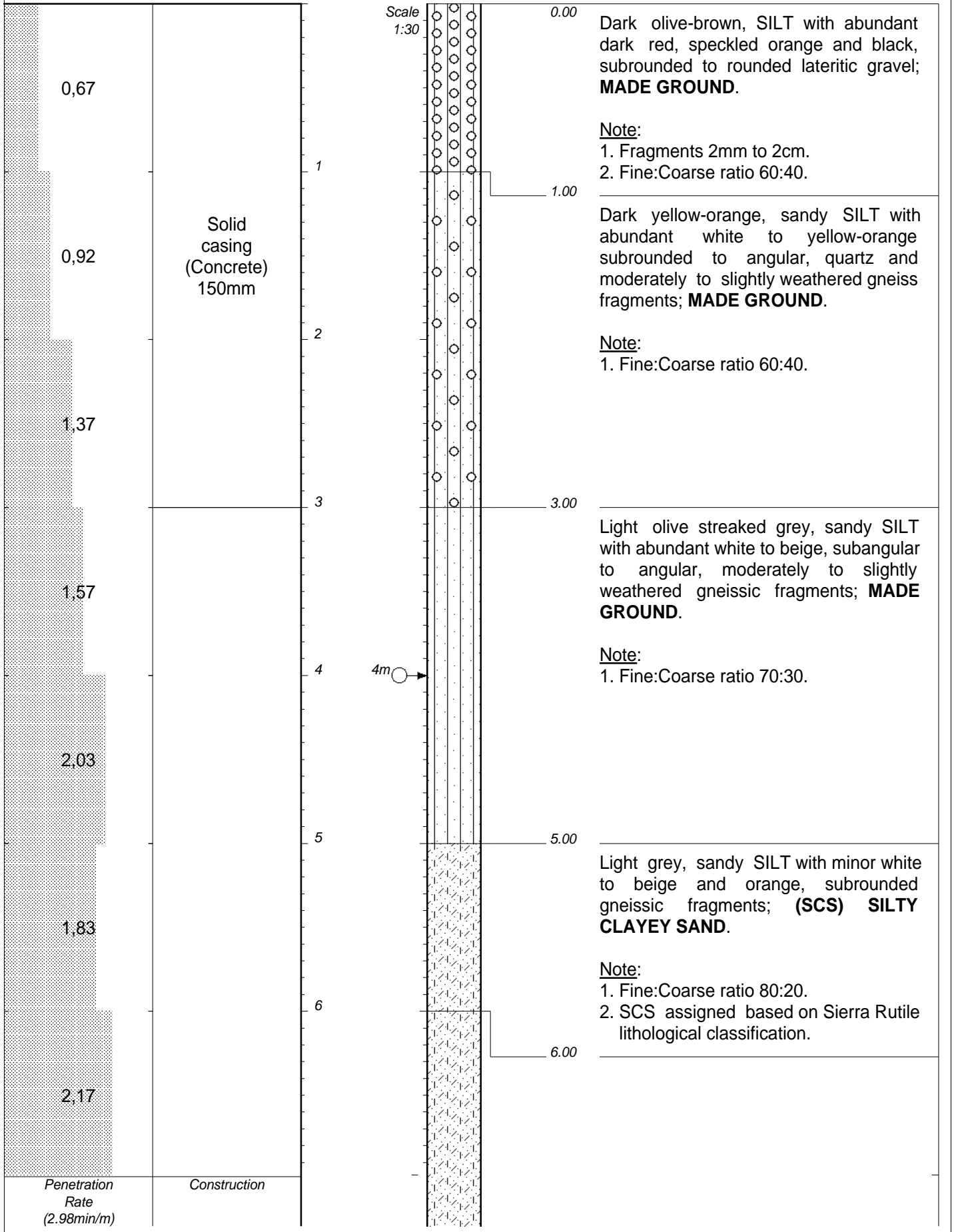
HOLE No: **SRL17-08B**



SIERRA RUTILE LTD.  
GROUND WATER MONITORING WELLS  
SR AREA 1

HOLE No: SRL17/09A  
Sheet 1 of 2

JOB NUMBER: 0

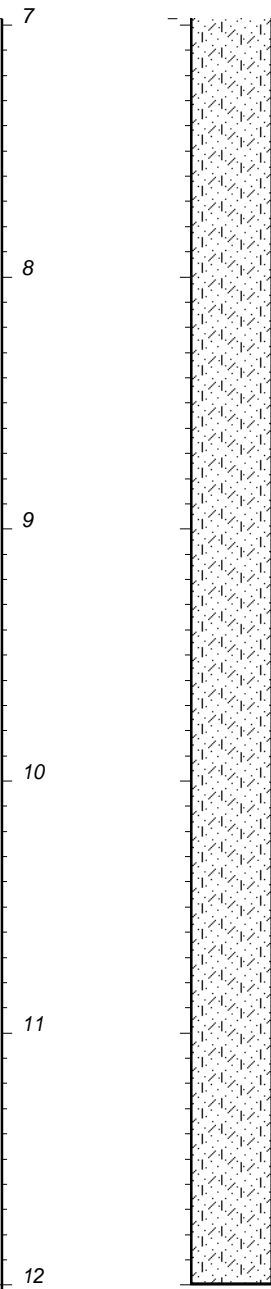
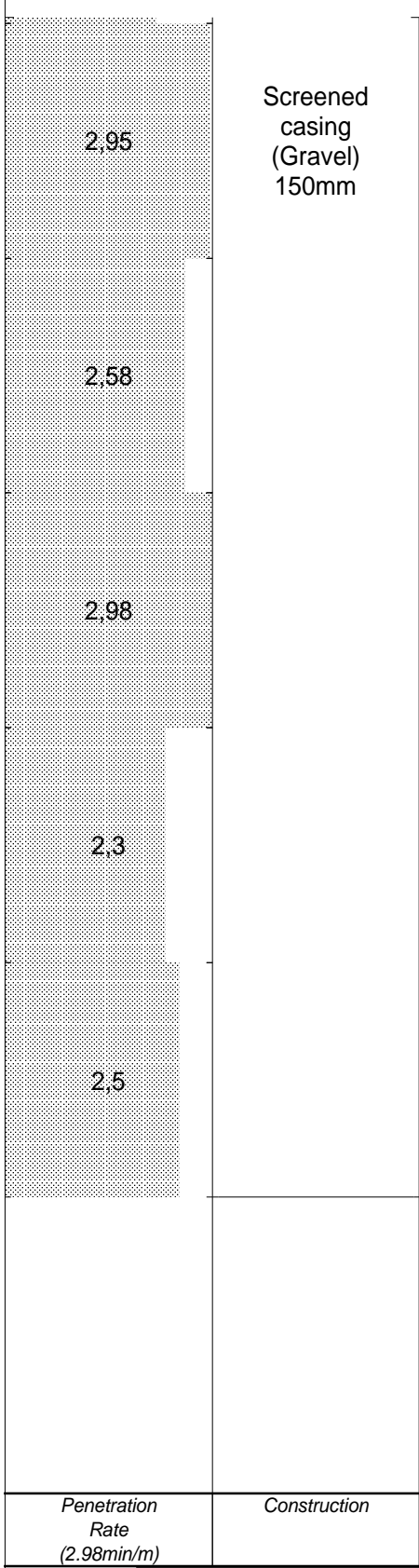




SIERRA RUTILE LTD.  
GROUND WATER MONITORING WELLS  
SR AREA 1

HOLE No: **SRL17/09A**  
Sheet 2 of 2

JOB NUMBER: 0



Grey olive-green silty clayey SAND with minor white to beige and orange, subangular to subrounded, quartz and gneissic fragments with traces of laterite;  
**(SCS) SILTY CLAYEY SAND.**

- Note:
1. Fragments 2mm - 2cm.
  2. Fine:Coarse ratio 80:20.

- NOTES**
- 1) Water seepage at 4m.
  - 2) Solid casing 0m-3m.
  - 3) Screened casing 3m-12m.
  - 4) Blow yield not possible due to low seepage.

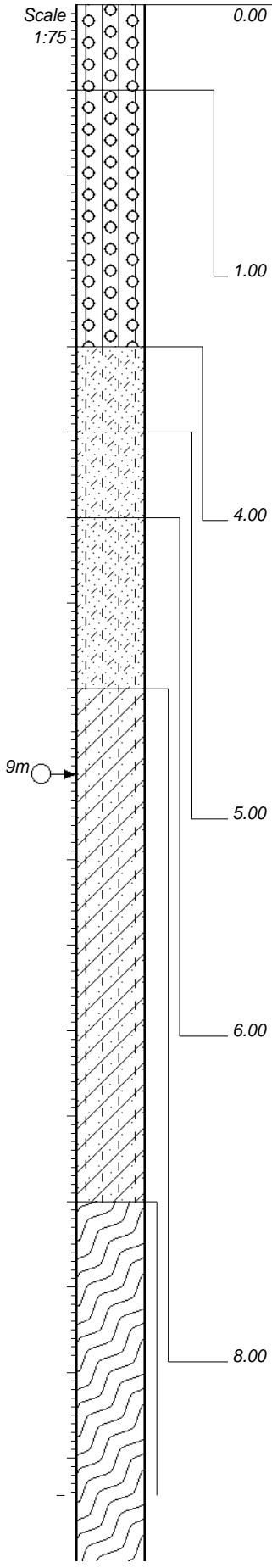
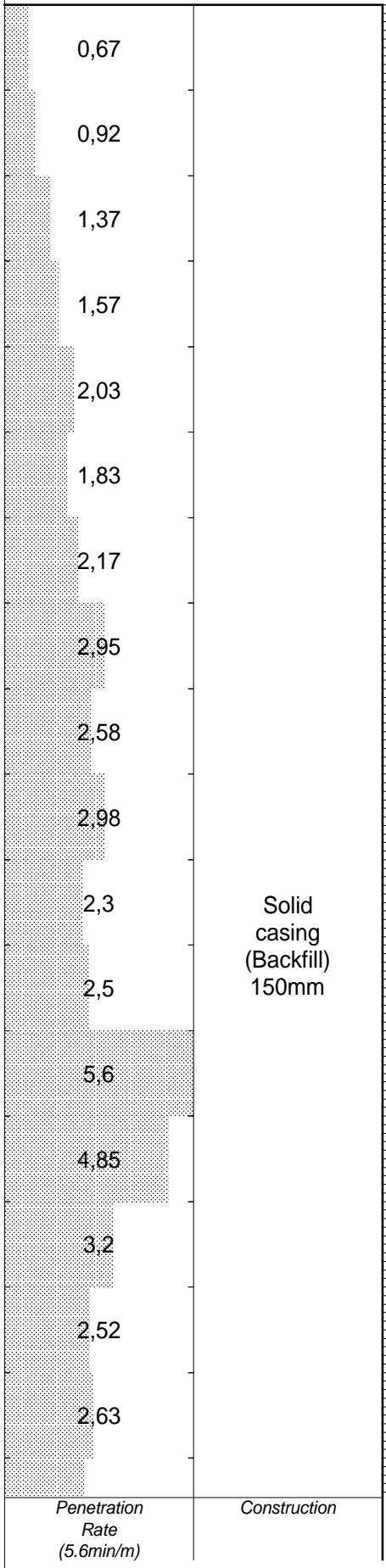
CONTRACTOR : Edal Drilling Company Ltd.	INCLINATION : Vertical	ELEVATION : 28m
MACHINE :	DIAM :	X-COORD : 795134
DRILLED BY :	DATE : 23 October 2017	Y-COORD : 850579
PROFILED BY : RK	DATE : 23 October 2017	
TYPE SET BY :	DATE : 16/02/2018 10:31	HOLE No: <b>SRL17/09A</b>
SETUP FILE : STANDARD.SET	TEXT : ..LVFINALSIERRALOGSALL.DOC	



SIERRA RUTILE LTD.  
GROUND WATER MONITORING WELLS  
SR AREA 1

HOLE No: SRL17/09B  
Sheet 1 of 2

JOB NUMBER: 0



Dark olive-green, brown and yellow, SILT with abundant subrounded, reddish orange speckled black, lateritic gravel; **MADE GROUND.**

Note:  
1. Gravel fragments 0.5cm to 2cm in size.  
2. Fine:Coarse ratio 60:40.

Dark yellow-orange SILT with abundant subrounded, dark red, speckled orange and black, lateritic fragments with traces of white angular quartz; **(LG) LATERITIC GRAVEL.**

Note:  
1. Fine:Coarse ratio 70:30.

Light olive streaked orange, clayey SILT with traces of white angular quartz with occasional laterite; **(SCS) SILTY CLAYEY SAND.**

Note:  
1. Fine:Coarse ratio 90:10.  
2. SCS assigned based on Sierra Rutile lithological classification.  
3. Rods damp at 4m.

Light grey-green speckled yellow, silty clayey SAND with traces of angular quartzitic gravel; **(SCS) SILTY CLAYEY SAND.**

Note:  
1. Fine:Coarse ratio 90:10.

Dark grey, sandy SILT with minor to abundant white to light grey angular quartz and black slightly weathered gneissic fragments; **(SCS) SILTY CLAYEY SAND**

Note:  
1. Fine:Coarse ratio 80:20  
2. Fragments 2mm-2cm in size.  
3. SCS assigned based on Sierra Rutile lithological classification.

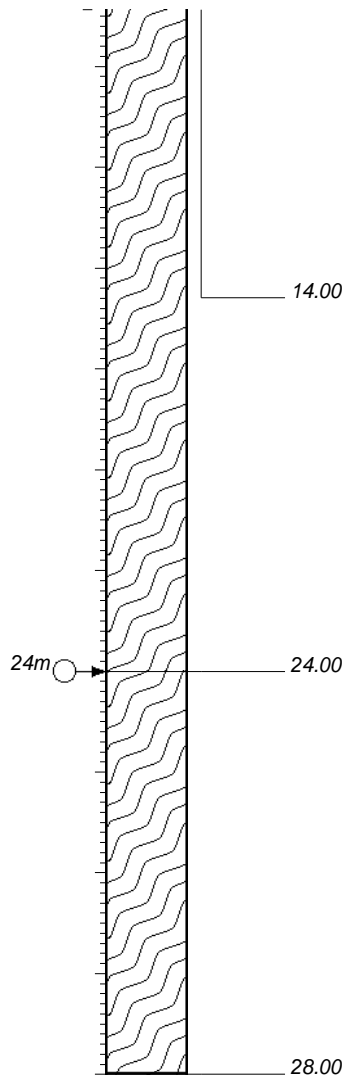
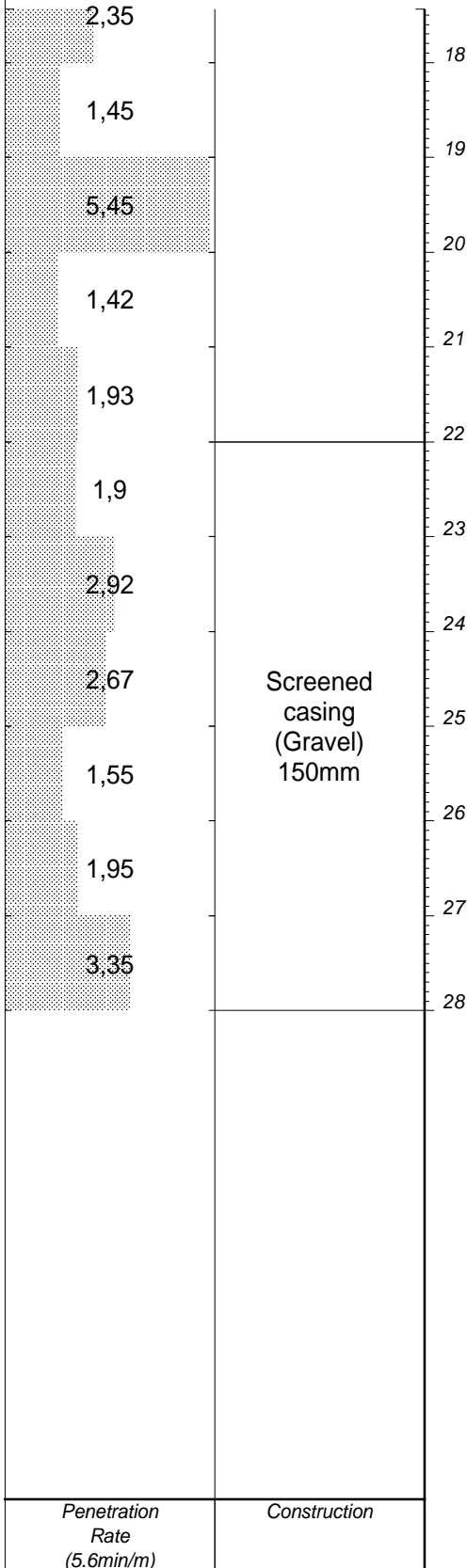


SIERRA RUTILE LTD.  
GROUND WATER MONITORING WELLS  
SR AREA 1

HOLE No: SRL17/09B

Sheet 2 of 2

JOB NUMBER: 0



Light grey-green streaked yellow, silty CLAY with traces of subangular, white to beige, quartzitic gravel and gneissic fragments; **(SCS) SILTY SANDY CLAY.**

Note:

1. Fine:Coarse ratio 90:10.
2. Some water at 9m.

Light grey-green, sandy SILT with minor white to beige and occasional black, gneissic fragments; **HIGHLY WEATHERED GNEISS BEDROCK.**

Note:

1. Fragments 2mm-0.5cm in size.
2. Fine: Coarse ratio 80:20.
3. Water strike at 24m.

Grey-green speckled black, angular gneissic fragments with traces of red garnet; **FRESH GNEISS.**

NOTES

- 1) Some water at 9m.
- 2) Water strike at 24m.
- 3) Solid casing 0m-22m.
- 4) Screened casing 22m-28m.
- 5) Blow yield 1.86 l/sec.

CONTRACTOR : Edal Drilling Company Ltd.

INCLINATION : Vertical

ELEVATION : 28m

MACHINE :  
DRILLED BY :  
PROFILED BY : RK

DIAM :  
DATE : 21 October 2017  
DATE : 21 October 2017

X-COORD : 795106  
Y-COORD : 850559

TYPE SET BY :  
SETUP FILE : STANDARD.SET

DATE : 16/02/2018 10:31  
TEXT : ..L\FINALSIERRALOGSALL.DOC

HOLE No: SRL17/09B

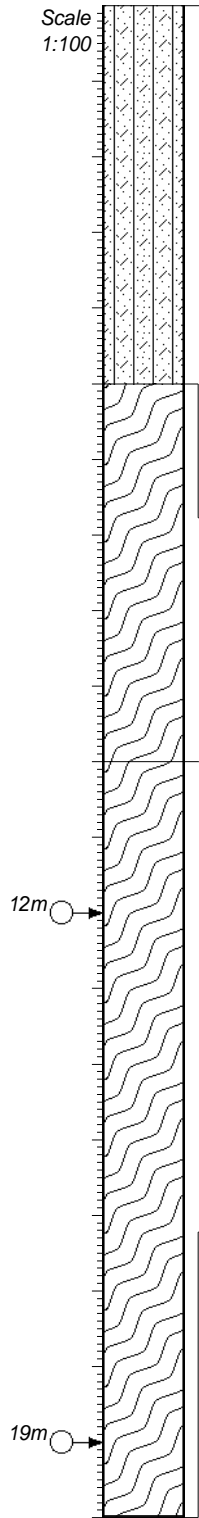


SIERRA RUTILE LTD.  
GROUND WATER MONITORING WELLS  
SR AREA 1

HOLE No: **SRL17-10**  
Sheet 1 of 1

JOB NUMBER: 0

0.49	Solid casing (Concrete) 150mm	1
0.48		2
0.47		3
0.33	Screened casing (Gravel) 150mm	4
0.38		5
3.35		6
3.45		7
3.55		8
4.02		9
4.08		10
4.44		11
4.45		12
4.44		13
4.53		14
4.47		15
4.50		16
4.56		17
4.58		18
4.59		19
5.02		20
Penetration Rate (5.02min/m)	Construction	



0.00 From sample: Orange-brown, clayey silty SAND to clayey sandy SILT with chips (2mm to 15mm) of highly weathered gneiss; **COMPLETELY WEATHERED GNEISS.**

**Note:**  
1. Fine:chip ratio from 1m to 2m 80:20 and from 3m to 5m 30:70.

From cutting: White streaked orange mottled brown and red, dense, relic rock structure and joints, clayey sandy SILT with abundant patches of highly weathered rock.

5.00 Grey with black, green and translucent chips (2mm to 5mm), highly fractured, **HIGHLY WEATHERED TO MODERATELY WEATHERED AMPHIBOLITE / GNEISS.**

10.00 Grey with black, green, translucent chips with a variety of colours, gravel chips 2mm to 10mm as well as large chips 100mm to 250mm, some gravel is subangular with staining on surfaces and pyrite and hydrothermal mineralization, fractured and jointed, hard rock **AMPHIBOLITE / GNEISS.**

20.00

**NOTES**

- 1) First water at 6m.
- 2) Large water strikes at 12m and 19m.
- 3) Solid casing from 0m to 3m.
- 4) Screened casing from 3m to 20m (150mm)
- 5) Blow yield 10 l/sec.
- 6) Dip water level at 4.5m on 27 September 2017.

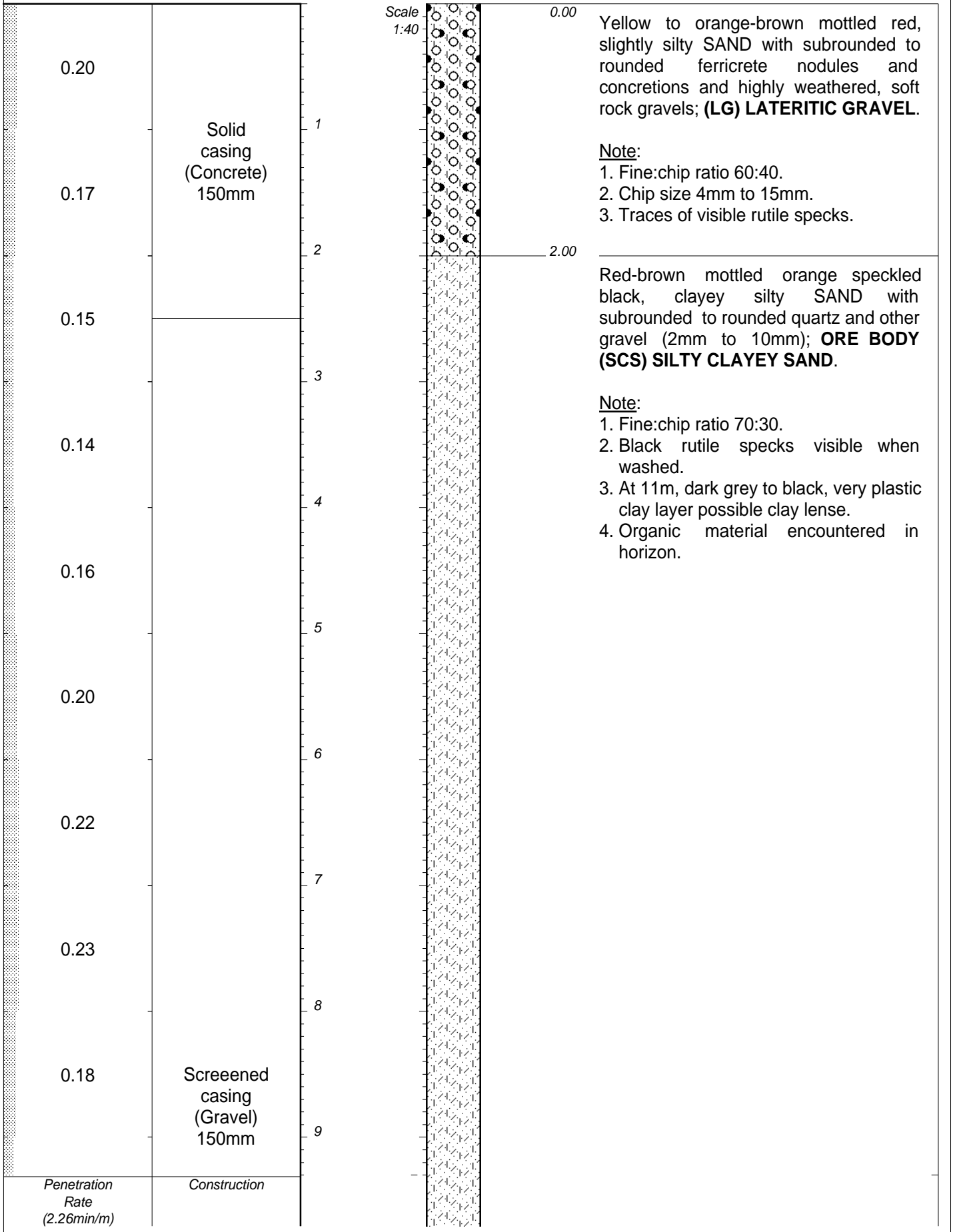
CONTRACTOR : Edal Drilling Co. Ltd.	INCLINATION : Vertical	ELEVATION : 12m
MACHINE :	DIAM :	X-COORD : 0791782
DRILLED BY :	DATE : 26 September 2017	Y-COORD : 0856043
PROFILED BY : MvR	DATE : 26 September 2017	
TYPE SET BY :	DATE : 16/02/2018 10:31	HOLE No: <b>SRL17-10</b>
SETUP FILE : STANDARD.SET	TEXT : ..L\FINALSIERRALOGSALL.DOC	



SIERRA RUTILE LTD.  
GROUND WATER MONITORING WELLS  
SR AREA 1

HOLE No: **SRL17-11A**  
Sheet 1 of 2

JOB NUMBER: 0



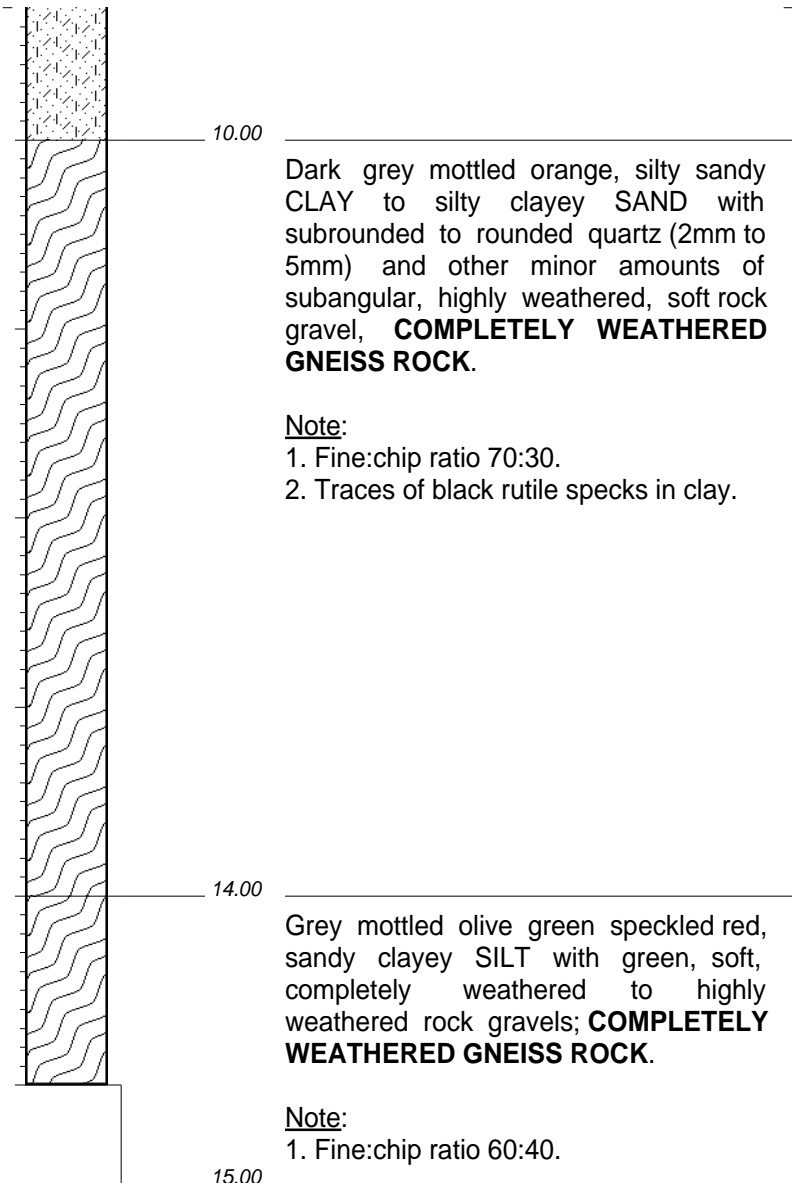
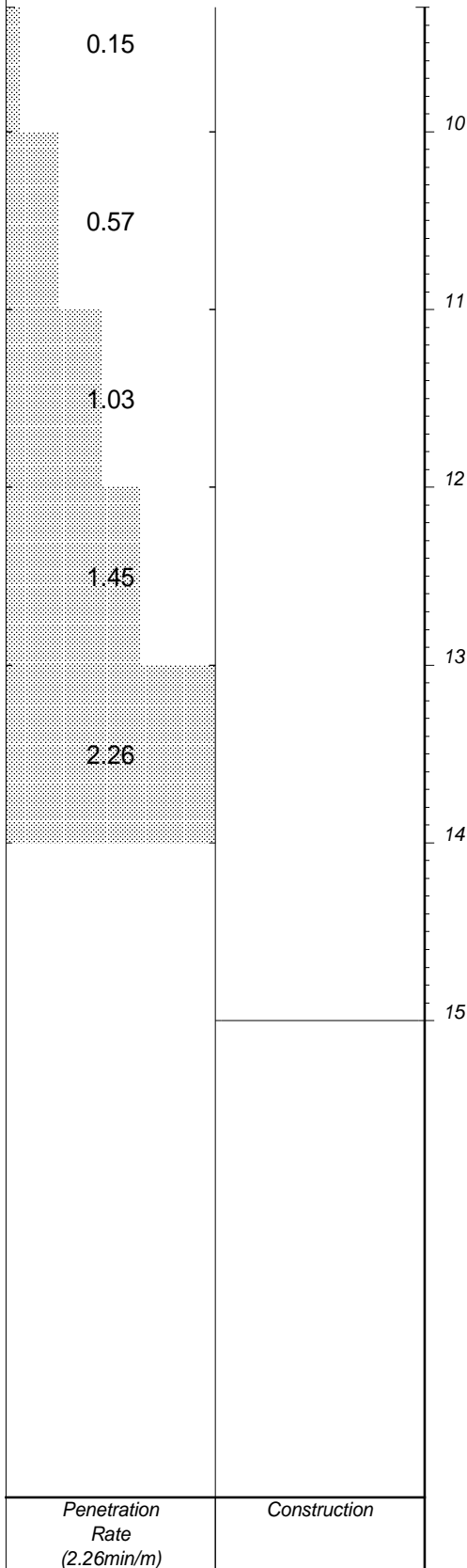




SIERRA RUTILE LTD.  
GROUND WATER MONITORING WELLS  
SR AREA 1

HOLE No: **SRL17-11A**  
Sheet 2 of 2

JOB NUMBER: 0



- NOTES
- 1) No water strike.
  - 2) Solid casing 0 to 2.5m (150mm) 0.4magl.
  - 3) Screened casing 2.5m to 15m (150mm).
  - 4) BH pair with SRL17-11B, 20m East drilled into rock.
  - 5) Blow yield approximately 0.5l/sec.
  - 6) Dip water level at 5.9mbgl on 29/09/2017.

CONTRACTOR : Edal Drilling Co. Ltd.

INCLINATION : Vertical

ELEVATION : 19m

MACHINE :  
DRILLED BY :  
PROFILED BY : MvR

DIAM :  
DATE : 28-29 September 2017  
DATE : 27 September 2017

X-COORD : 0791250  
Y-COORD : 0855902

TYPE SET BY :  
SETUP FILE : STANDARD.SET

DATE : 16/02/2018 10:31  
TEXT : ..\FINALSIERRALOGSALL.DOC

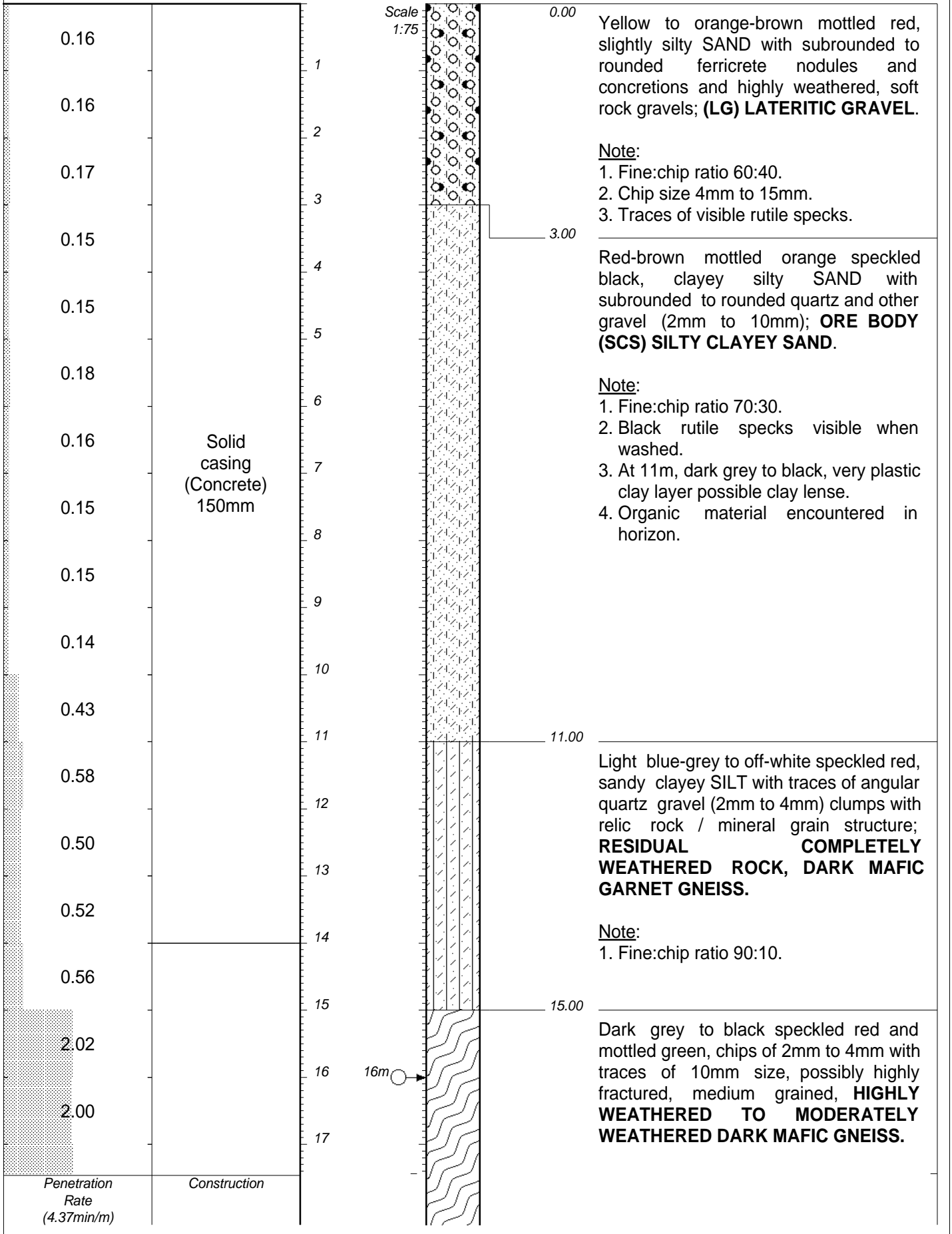
HOLE No: **SRL17-11A**



SIERRA RUTILE LTD.  
GROUND WATER MONITORING WELLS  
SR AREA 1

HOLE No: SRL17-11B  
Sheet 1 of 2

JOB NUMBER: 0

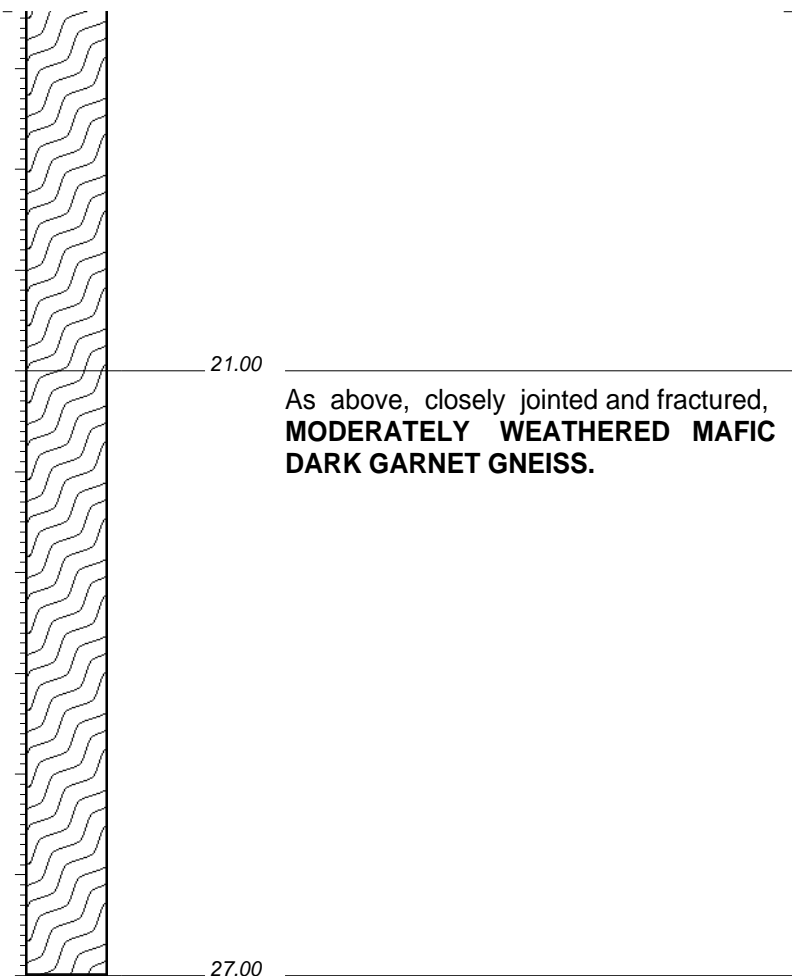
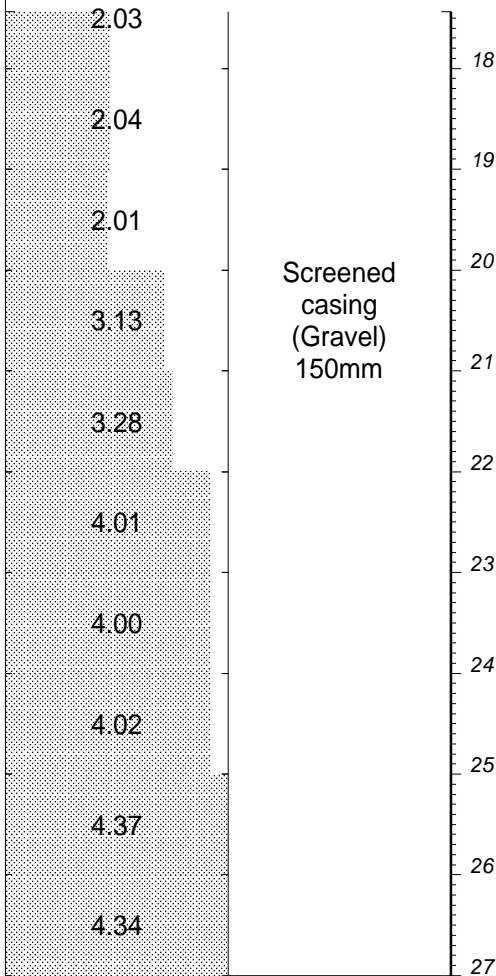




SIERRA RUTILE LTD.  
GROUND WATER MONITORING WELLS  
SR AREA 1

HOLE No: **SRL17-11B**  
Sheet 2 of 2

JOB NUMBER: 0



NOTES

- 1) Water encountered at approximately 4m to 5m.
- 2) Water strike at 16m.
- 3) Solid casing 0 - 14m (150mm) 0.6magl.
- 4) Screen casing 14m to 27m (150mm).
- 5) Dip water level at 5.6m on 29 September 2017.
- 6) Borehole pair with SRL17/11A drilled into ore body.
- 7) Blow yield 6-7l/sec.

Penetration Rate (4.37min/m)	Construction
---------------------------------	--------------

CONTRACTOR : Edal Drilling Co. Ltd.

INCLINATION : Vertical

ELEVATION : 13m

MACHINE :  
DRILLED BY :  
PROFILED BY : MvR

DIAM :  
DATE : 27 September 2017  
DATE : 27 September 2017

X-COORD : 0791255  
Y-COORD : 0855877

TYPE SET BY :  
SETUP FILE : STANDARD.SET

DATE : 16/02/2018 10:31  
TEXT : ..\L\FINALSIERRALOGSALL.DOC

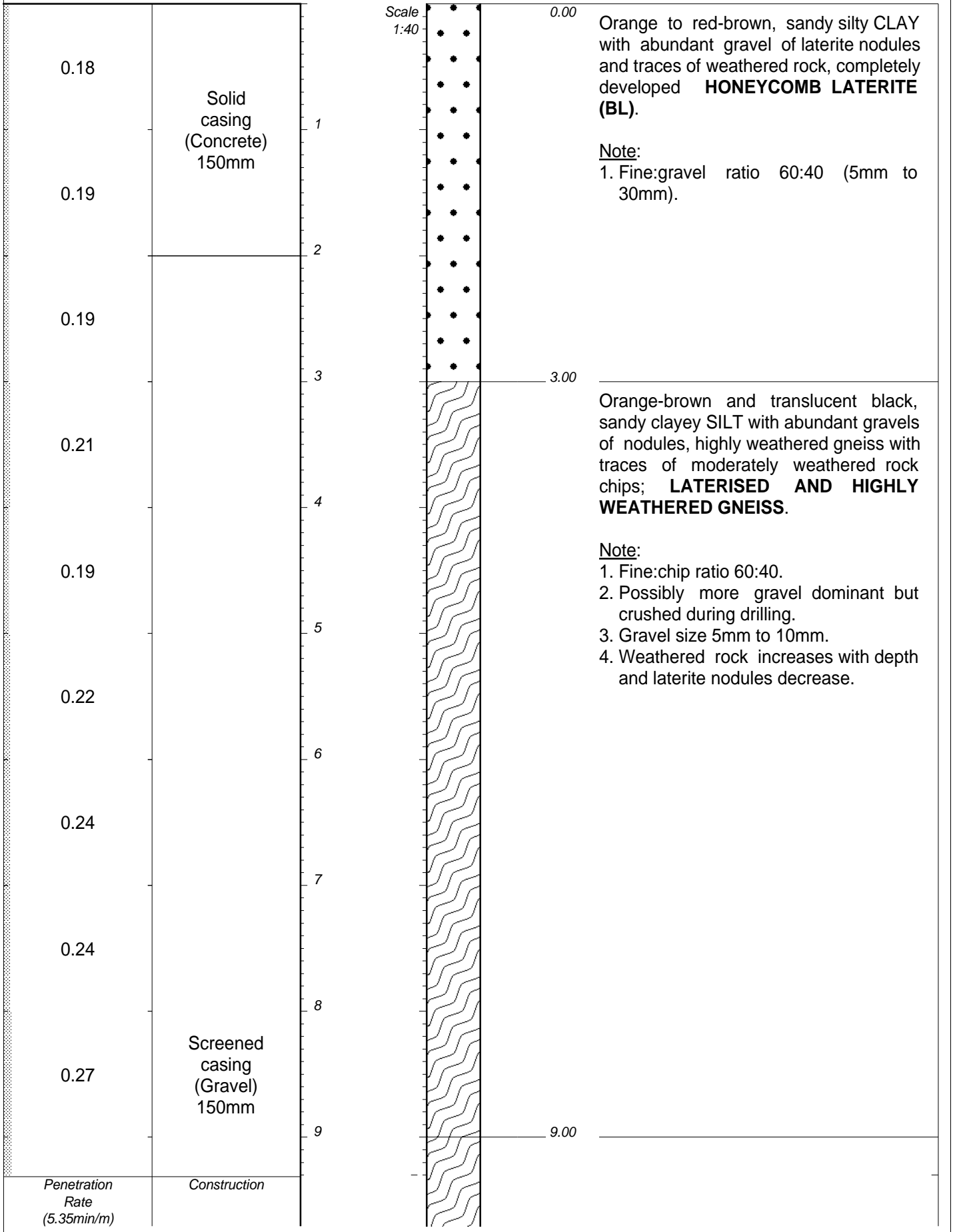
HOLE No: **SRL17-11B**



SIERRA RUTILE LTD.  
GROUND WATER MONITORING WELLS  
SR AREA 1

HOLE No: SRL17-12  
Sheet 1 of 2

JOB NUMBER: 0

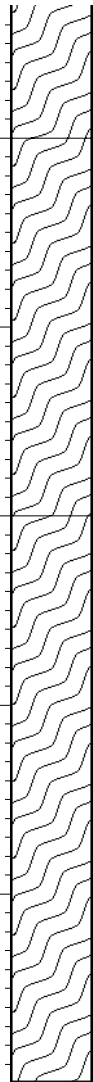
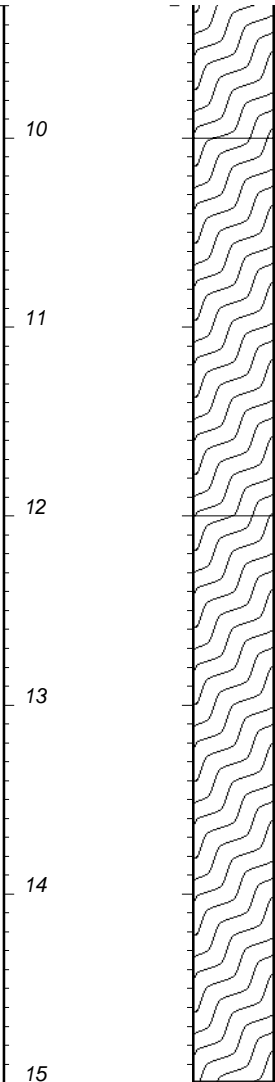
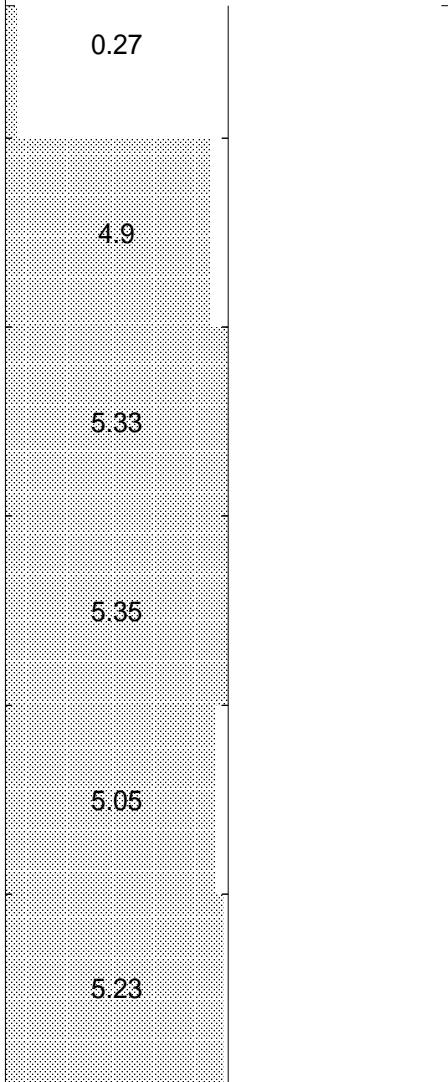




SIERRA RUTILE LTD.  
GROUND WATER MONITORING WELLS  
SR AREA 1

HOLE No: **SRL17-12**  
Sheet 2 of 2

JOB NUMBER: 0



Transition zone from highly weathered rock to medium weathered, moderately fractured GNEISS. Orange-brown for highly weathered and light grey translucent for medium weathered **GNEISS**.

Note:  
1. Chip size 1mm to 4mm.

Dark to light grey specked red chips with streaks of white and translucent, medium weathered to slightly weathered GNEISS with visible staining and rounding chip edges; **FRACTURED, MODERATELY TO SLIGHTLY WEATHERED GNEISS**.

Note:  
1. Chips 1mm to 5mm.

As above but fresh rock, possibly slightly fractured.

Note:  
1. Chips 1mm to 3mm.

--	--

Penetration Rate (5.35min/m)	Construction
---------------------------------	--------------

- NOTES**
- 1) No water strike.
  - 2) Slow recovery of water encountered.
  - 3) No blow yield done due to slow seepage.

CONTRACTOR : Edal Drilling Co. Ltd.  
MACHINE :  
DRILLED BY :  
PROFILED BY : MvR  
TYPE SET BY :  
SETUP FILE : STANDARD.SET

INCLINATION : Vertical  
DIAM :  
DATE : 16-17 August 2017  
DATE : 23 September 2017  
DATE : 16/02/2018 10:31  
TEXT : ..LVFINALSIERRALOGSALL.DOC

ELEVATION : 74m  
X-COORD : 790024  
Y-COORD : 862395

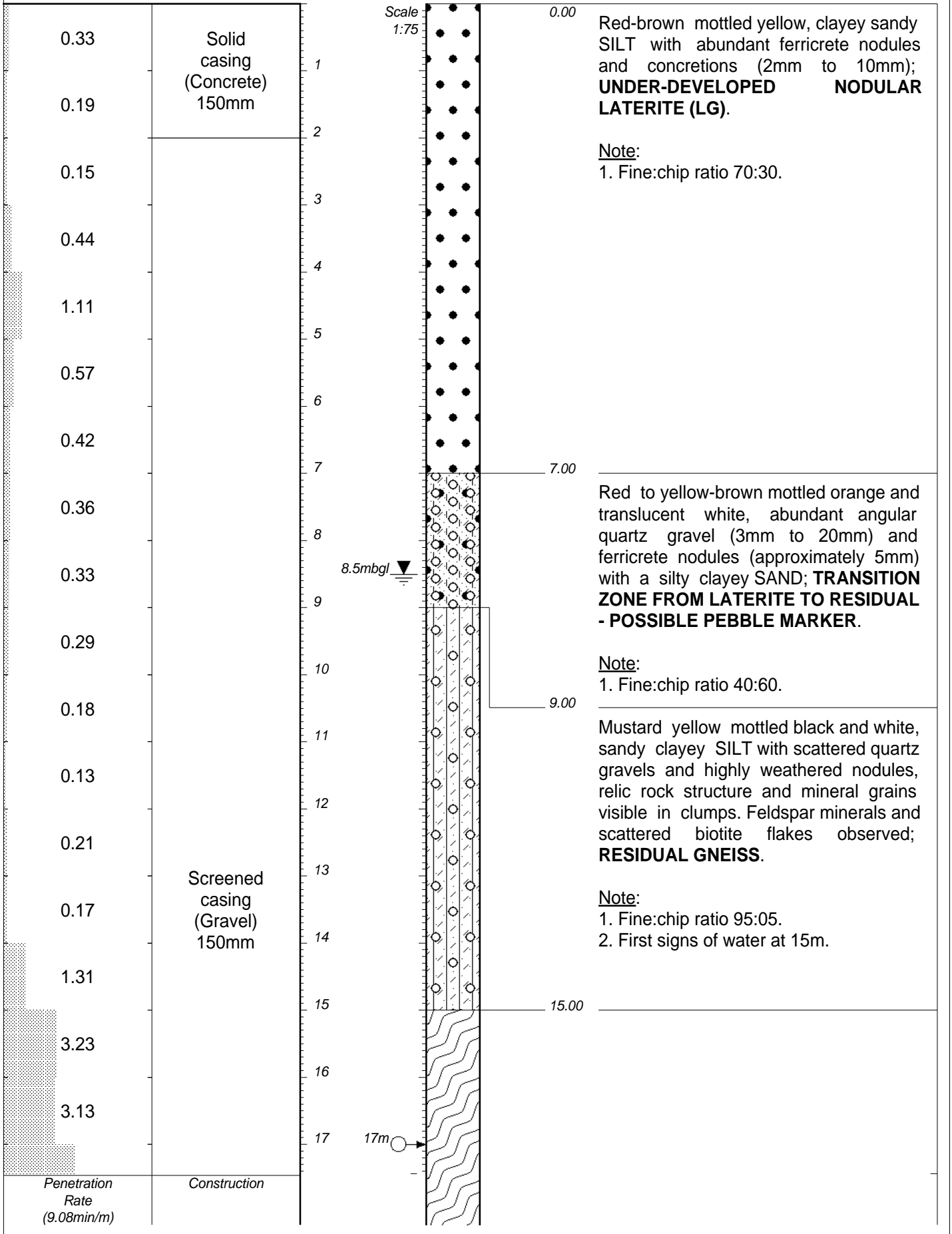
HOLE No: **SRL17-12**



SIERRA RUTILE LTD.  
GROUND WATER MONITORING WELLS  
SR AREA 1

HOLE No: SRL17-13  
Sheet 1 of 2

JOB NUMBER: 0

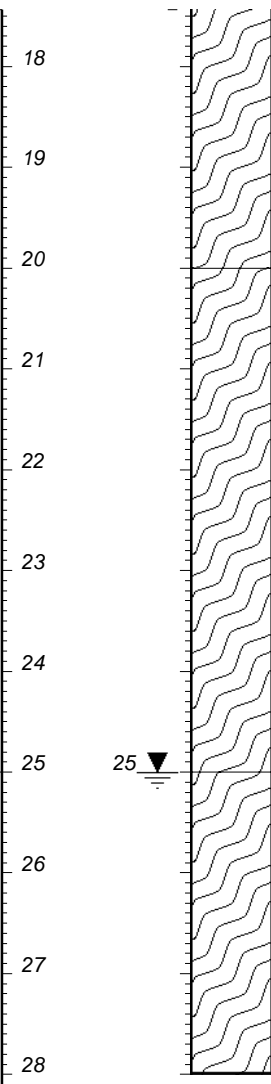
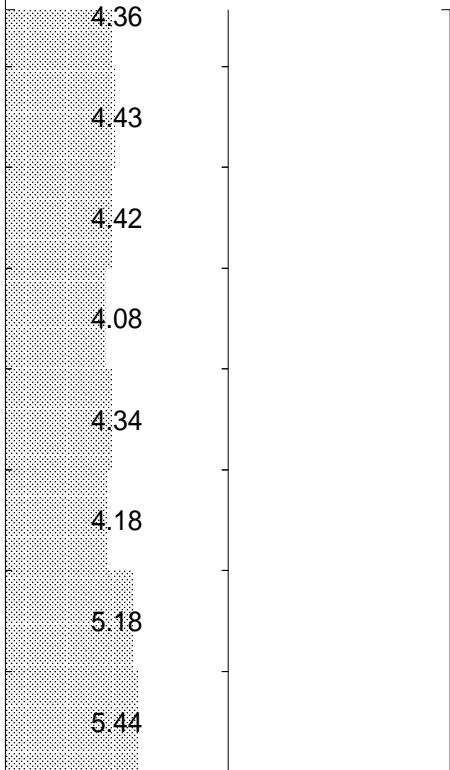




SIERRA RUTILE LTD.  
GROUND WATER MONITORING WELLS  
SR AREA 1

HOLE No: **SRL17-13**  
Sheet 2 of 2

JOB NUMBER: 0



Light orange-brown fines with mostly translucent, white, angular quartz gravels (2mm to 20mm) with traces of brown, highly weathered rock chips (1mm to 10mm), possibly highly fractured zone, highly weathered **GNEISS** with abundant large quartz veins.

Note:  
1. Fine:chip ratio 15:85.

Grey mottled black and translucent, angular gravel (2mm to 5mm) of moderately weathered rock (gneiss) with scattered biotite flakes, fractured; **MODERATELY WEATHERED BIOTITE GARNET QUARTZITIC GNEISS** with scattered gravels (50mm to 80mm).

Grey drill dust with scattered gravel (50mm to 80mm) of slightly weathered GNEISS, **SLIGHTLY WEATHERED AND SLIGHTLY FRACTURED GNEISS.**

- NOTES**
- 1) Water strike at 17m.
  - 2) Solid casing 0m to 2m.
  - 3) Screened casing 2m to 25m.
  - 4) Blow yield 4.5l/sec.
  - 5) Dip water level at 8.5mbgl on 25 September 2017.

Penetration Rate (9.08min/m)	Construction
---------------------------------	--------------

<p>CONTRACTOR : Edal Drilling Co. Ltd. MACHINE : DRILLED BY : PROFILED BY : MvR TYPE SET BY : SETUP FILE : STANDARD.SET</p>	<p>INCLINATION : Vertical DIAM : DATE : 20-21 September 2017 DATE : 23 September 2017 DATE : 16/02/2018 10:31 TEXT : ..\L\FINALSIERRALOGSALL.DOC</p>	<p>ELEVATION : 57m X-COORD : 0800377 Y-COORD : 0856477</p>
---	--	--

HOLE No: **SRL17-13**

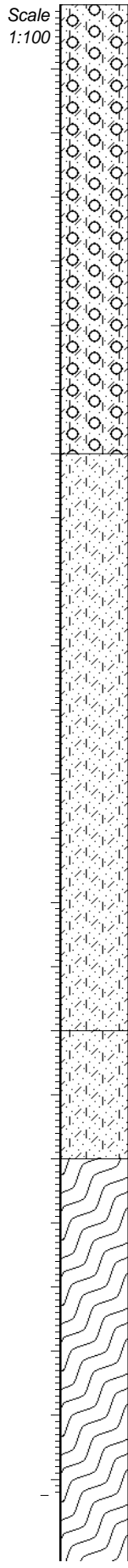


SIERRA RUTILE LTD.  
GROUND WATER MONITORING WELLS  
SR AREA 1

HOLE No: SRL17/14  
Sheet 1 of 2

JOB NUMBER: 0

1,72	Solid casing (Concrete) 150mm	1
1,3		2
2,3	Screened casing (Gravel) 150mm	3
3		4
7,36		5
5,42		6
4,3		7
2,63		8
5,35		9
6,2		10
3,63		11
4,17		12
2,47		13
4,72		14
5,35		15
4,48		16
6,08		17
6,65		18
10,18		19
5,95		20
2,95		21
4,37	22	
8,18	23	
Penetration Rate (10.18min/m)	Construction	



0.00  
Dark olive-brown to yellow-orange, SILT with abundant red, speckled orange and black, subangular lateritic gravel and white to beige, subangular quartz; **(SCS) SILTY CLAYEY SAND.**

Note:  
1. Fragments 2-3mm in size.  
2. Fine:Coarse ratio 80:20.  
3. SCS assigned based on Sierra Rutile lithological classification.

7.00  
Beige to dark pinkish brown, silty fine to medium SAND with abundant white to beige, subangular quartz; **(SCS) SILTY CLAYEY SAND.**

Note:  
1. Fragments 2-3mm in size.  
2. Fine:Coarse ratio 40:60.

16.00  
Pink, slightly clayey SILT with some white to beige, subangular quartz; **(SCS) SILTY CLAYEY SAND.**

Note:  
1. Fragments 2mm.  
2. Fine:Coarse ratio 60:40.

18.00

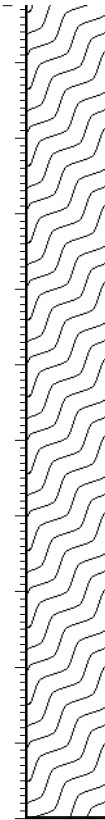
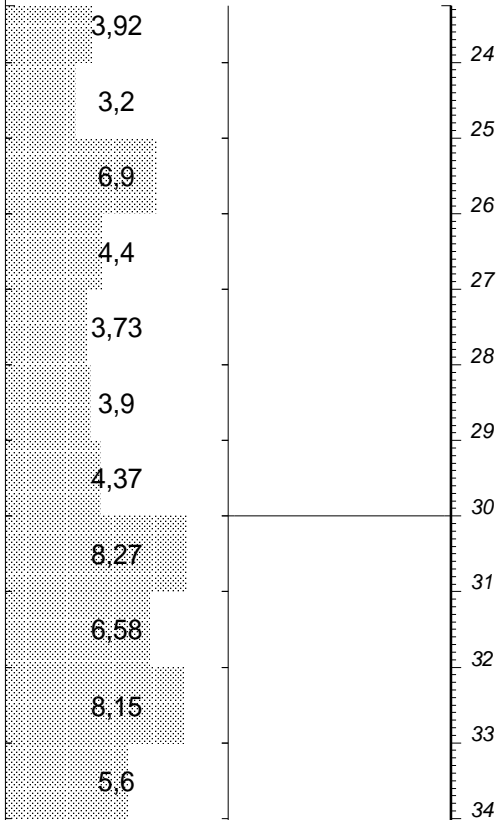




SIERRA RUTILE LTD.  
GROUND WATER MONITORING WELLS  
SR AREA 1

HOLE No: **SRL17/14**  
Sheet 2 of 2

JOB NUMBER: 0



Pink, white and grey, slightly clayey sandy SILT with abundant white to beige, subangular quartz and traces of moderately weathered gneiss;  
**COMPLETELY WEATHERED GNEISS BEDROCK.**

- Note:
1. Fragments 2-3mm in size.
  2. Fine:Coarse ratio 60:40.

34.00

**NOTES**

- 1) This hole was drilled mud rotary so logging has been influenced.
- 2) No obvious water strike due to mud rotary drilling.
- 3) Solid casing 0m-2m.
- 4) Screened casing 2m-30m.
- 5) Blow yield 32 l/sec.

Penetration Rate (10.18min/m)	Construction
----------------------------------	--------------

CONTRACTOR : Edal Drilling Company Ltd.

INCLINATION : Vertical

ELEVATION : 20m

MACHINE :  
DRILLED BY :  
PROFILED BY : RK

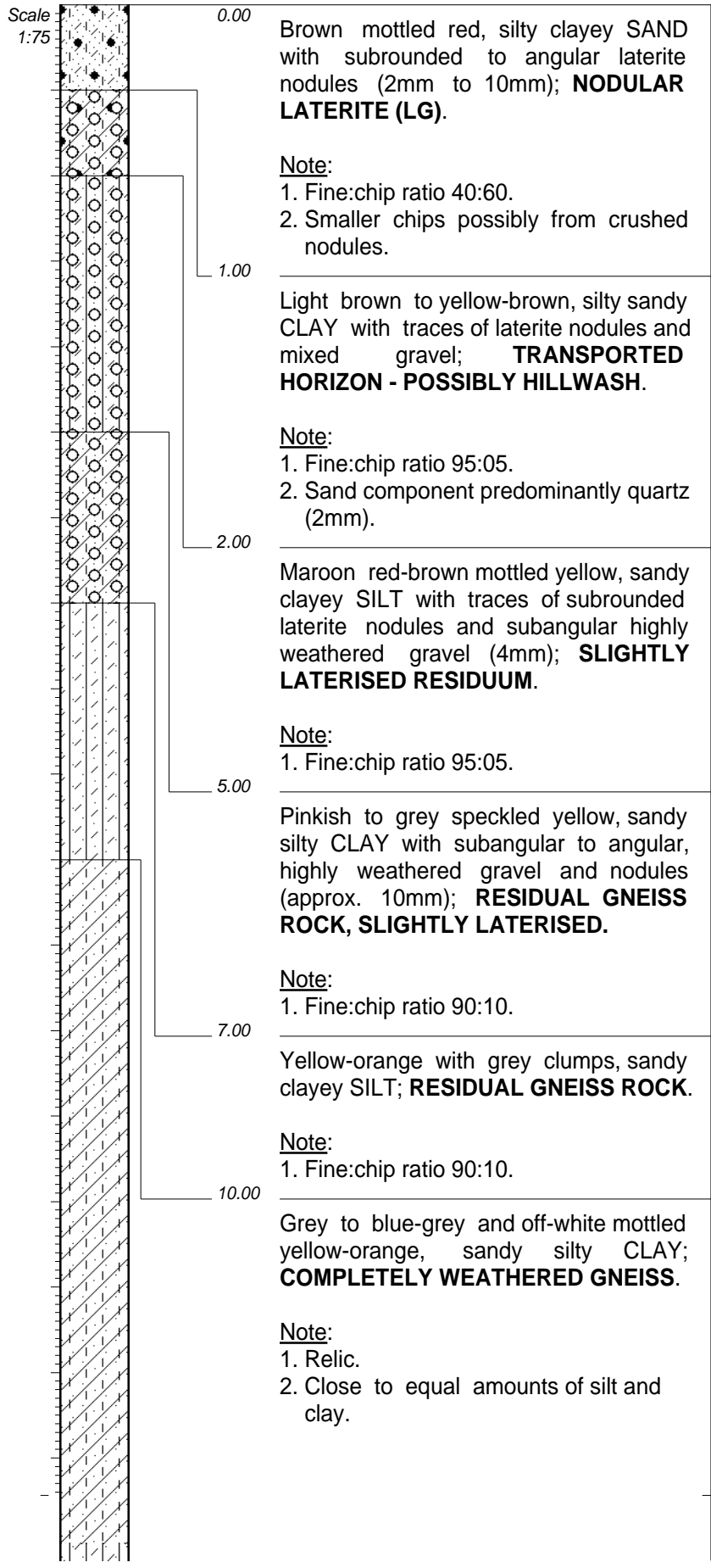
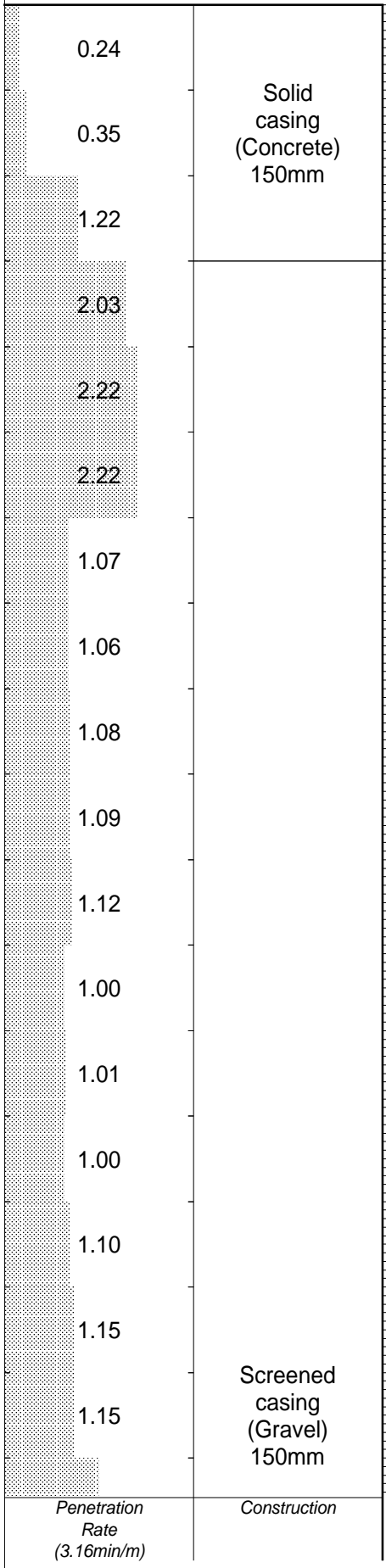
DIAM :  
DATE : 2 November 2017  
DATE : 2 November 2017

X-COORD : 796494  
Y-COORD : 846914

TYPE SET BY :  
SETUP FILE : STANDARD.SET

DATE : 16/02/2018 10:31  
TEXT : ..L\FINALSIERRALOGSALL.DOC

HOLE No: **SRL17/14**

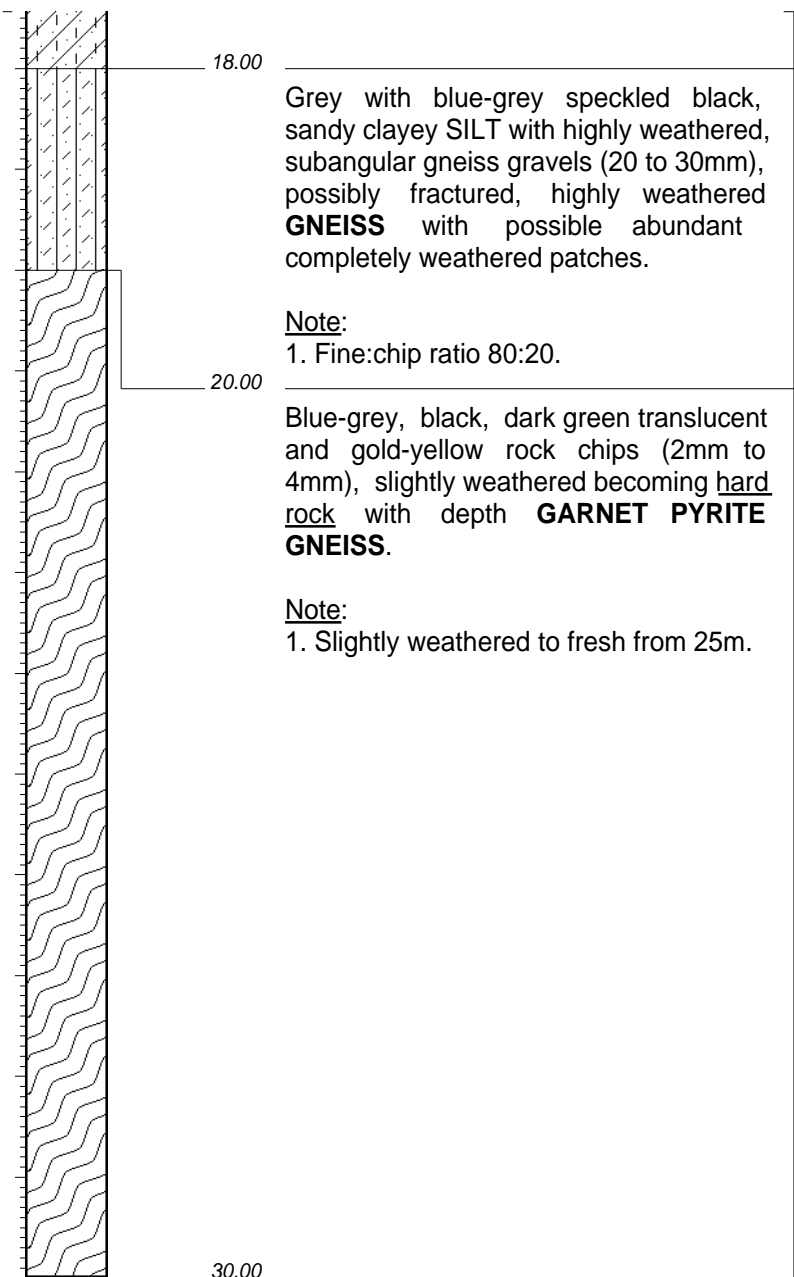
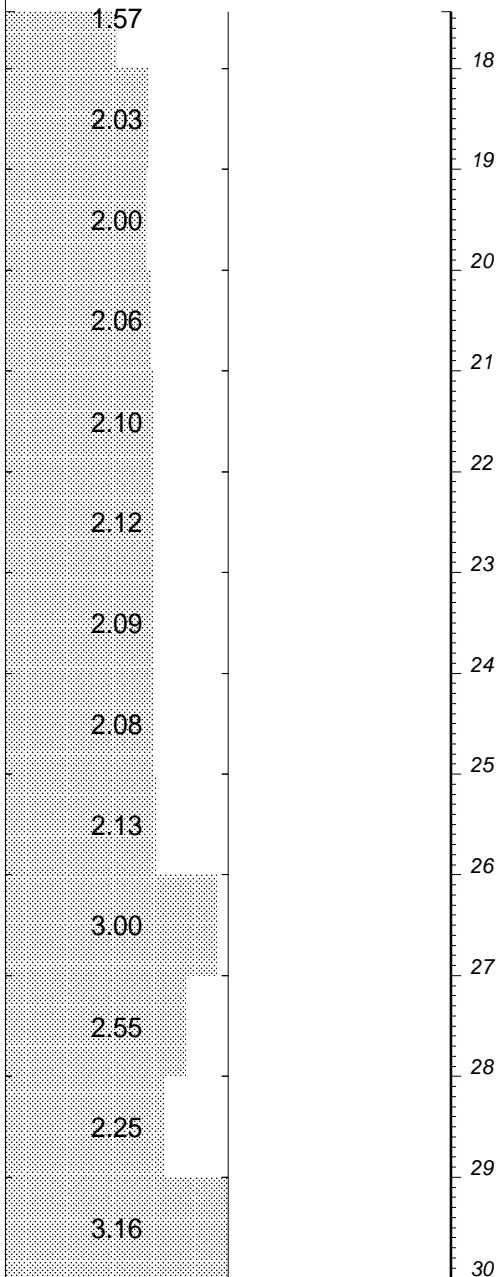




SIERRA RUTILE LTD.  
GROUND WATER MONITORING WELLS  
SR AREA 1

HOLE No: **SRL17-15**  
Sheet 2 of 2

JOB NUMBER: 0



Penetration Rate (3.16min/m)	Construction

- NOTES
- 1) Solid casing 0m-3m.
  - 2) Screened casing 3m-30m.
  - 3) Blow yield 1.5l/sec.

CONTRACTOR : Edal Drilling Co. Ltd.  
MACHINE :  
DRILLED BY :  
PROFILED BY : MvR  
TYPE SET BY :  
SETUP FILE : STANDARD.SET

INCLINATION :  
DIAM :  
DATE : 3 October 2017  
DATE : 3 October 2017  
DATE : 16/02/2018 10:31  
TEXT : ..LVFINALSIELLALOGSALL.DOC

ELEVATION : 49m  
X-COORD : 0803421  
Y-COORD : 0858193

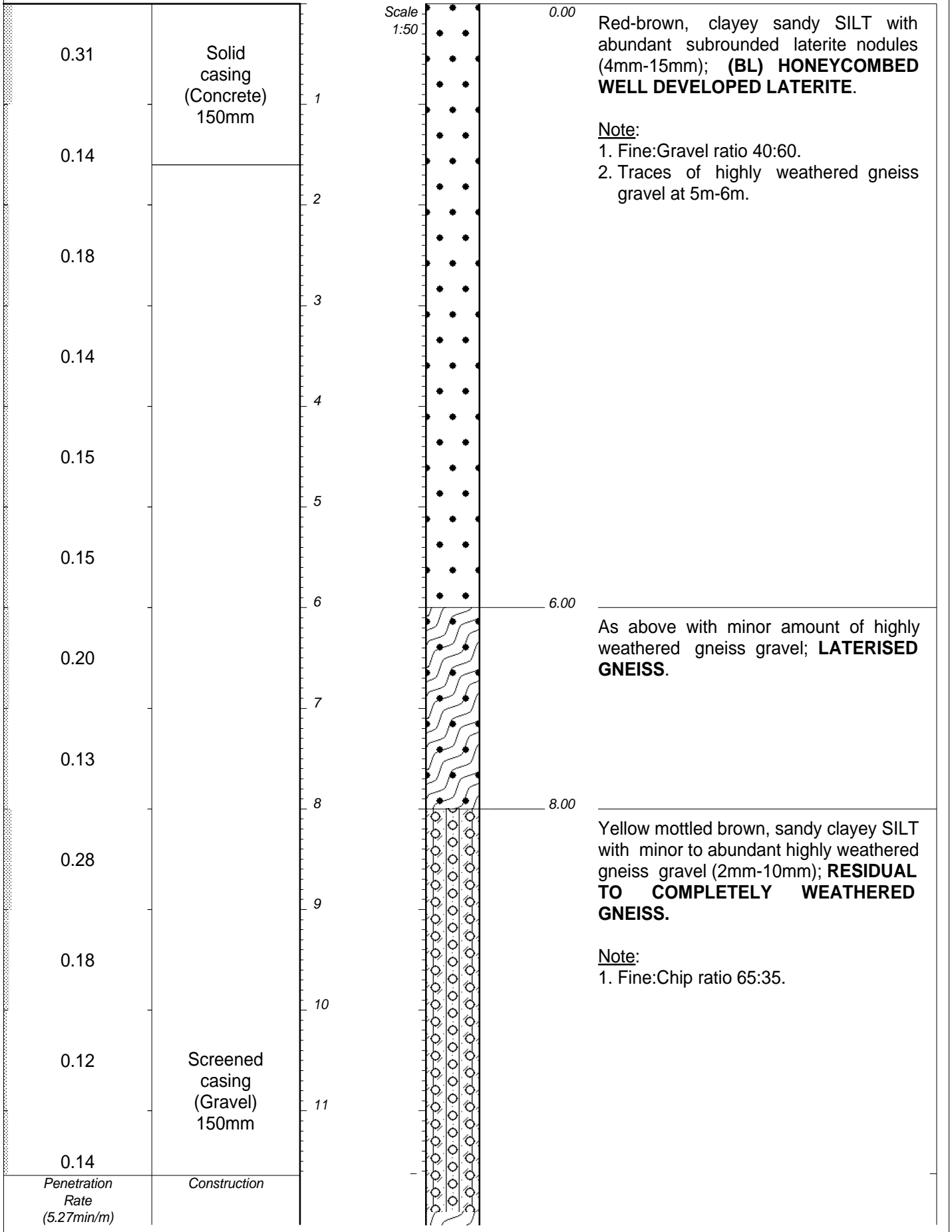
HOLE No: **SRL17-15**



SIERRA RUTILE LTD.  
GROUND WATER MONITORING WELLS  
SR AREA 1

HOLE No: SRL17-16  
Sheet 1 of 2

JOB NUMBER: 0

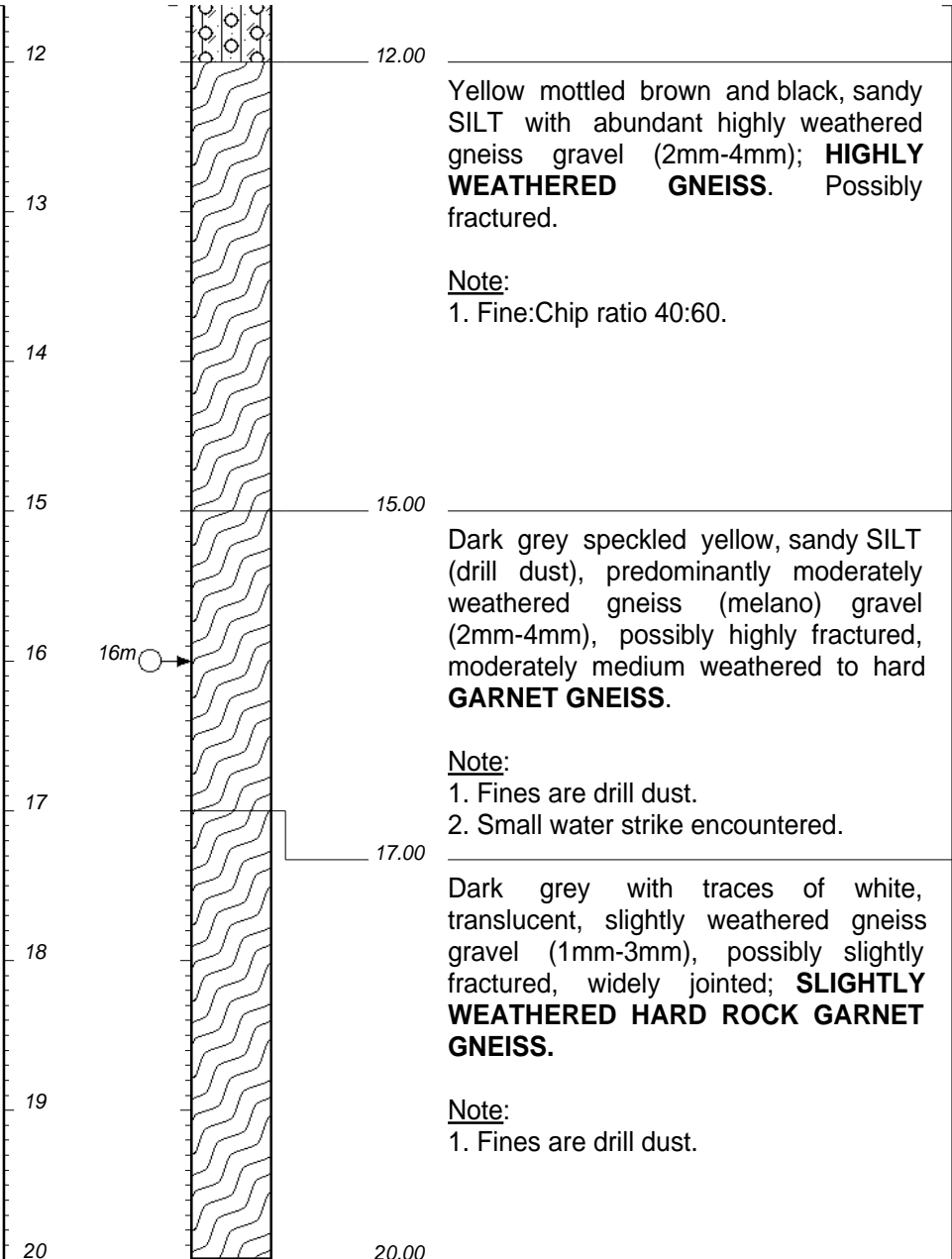
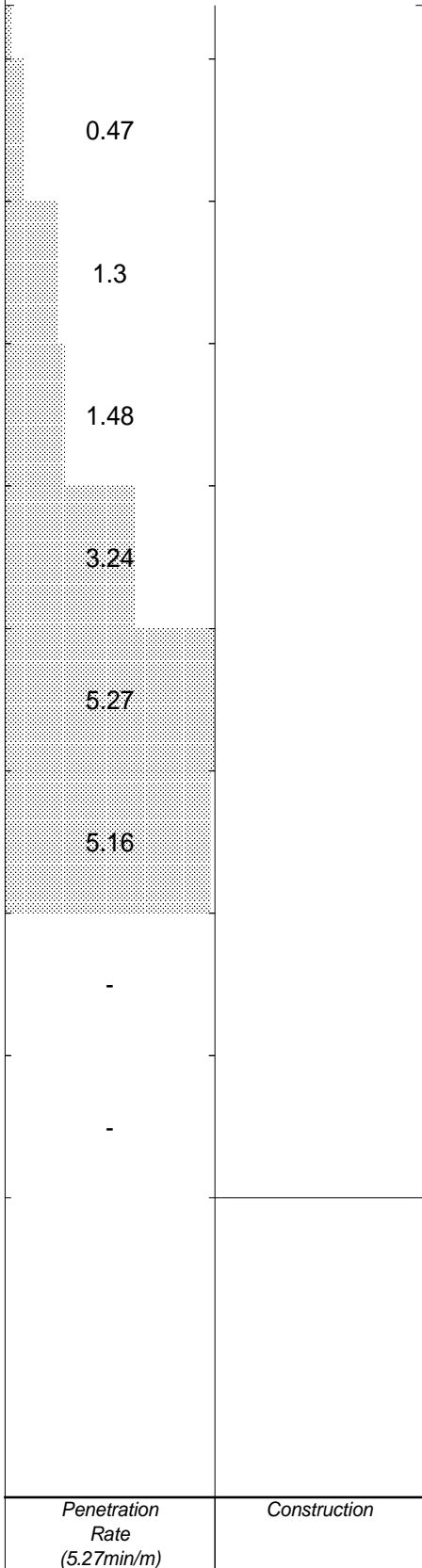




SIERRA RUTILE LTD.  
GROUND WATER MONITORING WELLS  
SR AREA 1

HOLE No: **SRL17-16**  
Sheet 2 of 2

JOB NUMBER: 0



Yellow mottled brown and black, sandy SILT with abundant highly weathered gneiss gravel (2mm-4mm); **HIGHLY WEATHERED GNEISS.** Possibly fractured.

Note:  
1. Fine:Chip ratio 40:60.

Dark grey speckled yellow, sandy SILT (drill dust), predominantly moderately weathered gneiss (melano) gravel (2mm-4mm), possibly highly fractured, moderately medium weathered to hard **GARNET GNEISS.**

Note:  
1. Fines are drill dust.  
2. Small water strike encountered.

Dark grey with traces of white, translucent, slightly weathered gneiss gravel (1mm-3mm), possibly slightly fractured, widely jointed; **SLIGHTLY WEATHERED HARD ROCK GARNET GNEISS.**

Note:  
1. Fines are drill dust.

- NOTES
- 1) Solid casing approximately 0.50magl to 1.60mbgl. Low yielding. Concrete 0m-1.6m.
  - 2) Screened casing 1.6mbgl-20mbgl. Gravel 1.6m-20m.
  - 3) Small water strike at 16m.
  - 4) Dip water on 25/09/2017 at 11.6mbgl.

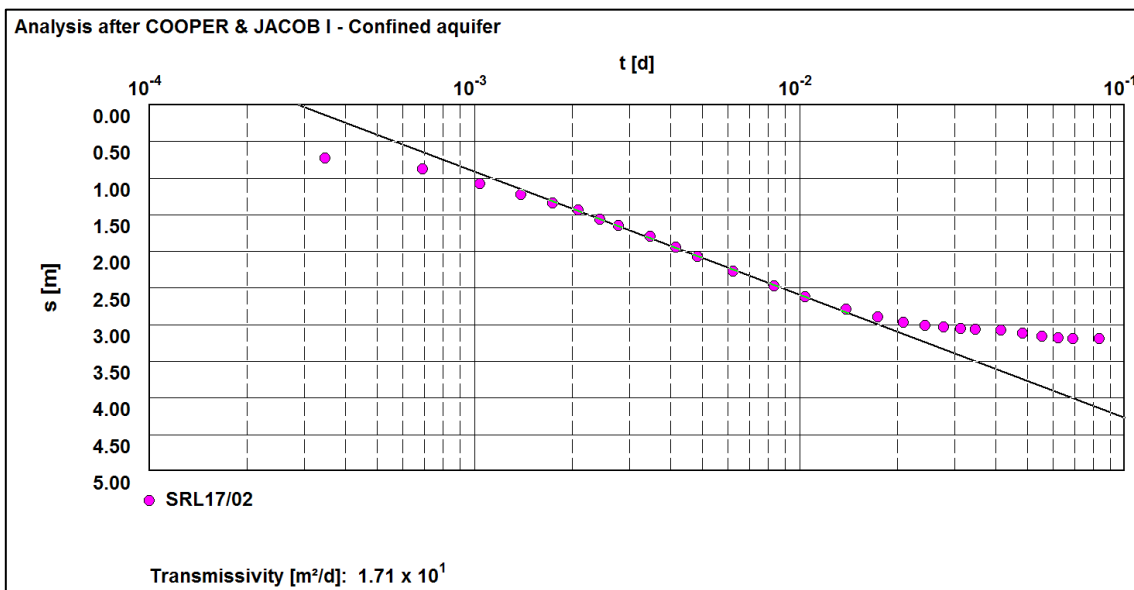
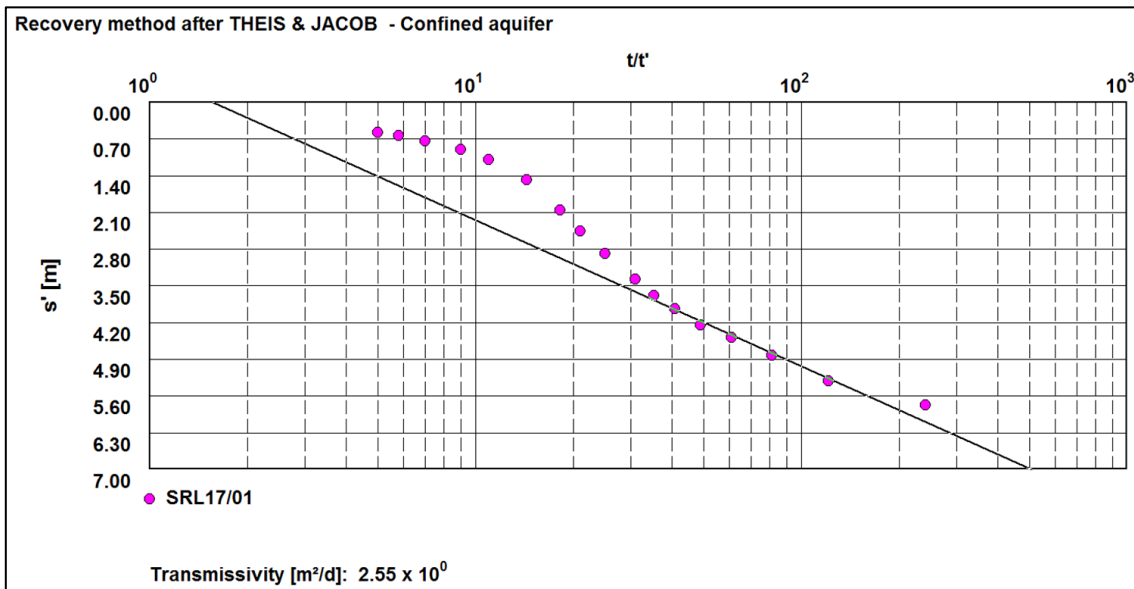
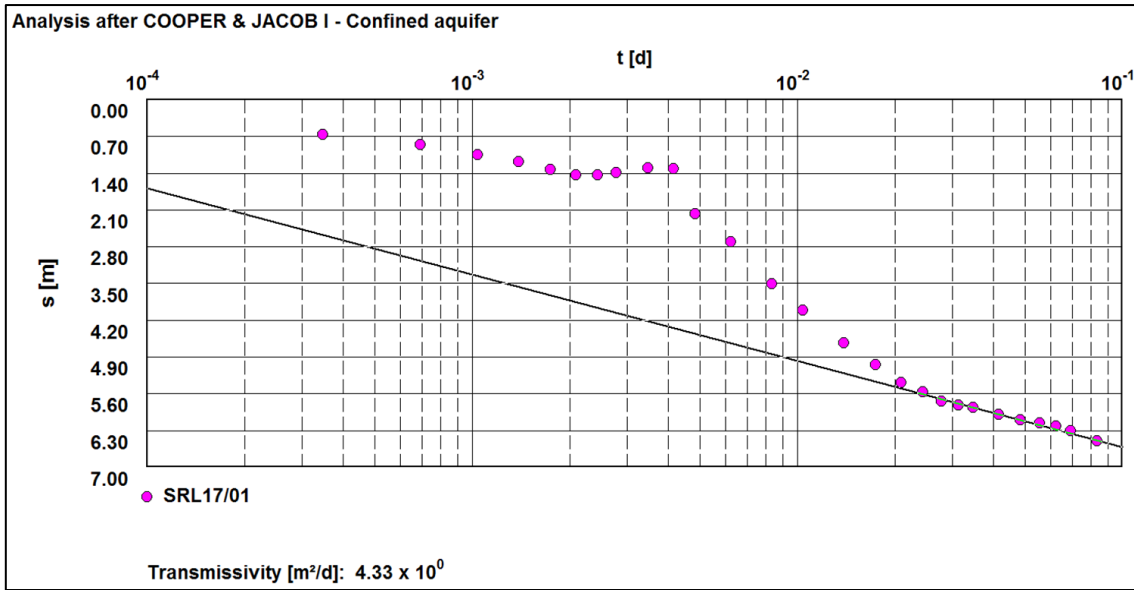
CONTRACTOR : Edal Drilling Co. Ltd.  
MACHINE :  
DRILLED BY :  
PROFILED BY : MvR  
TYPE SET BY :  
SETUP FILE : STANDARD.SET

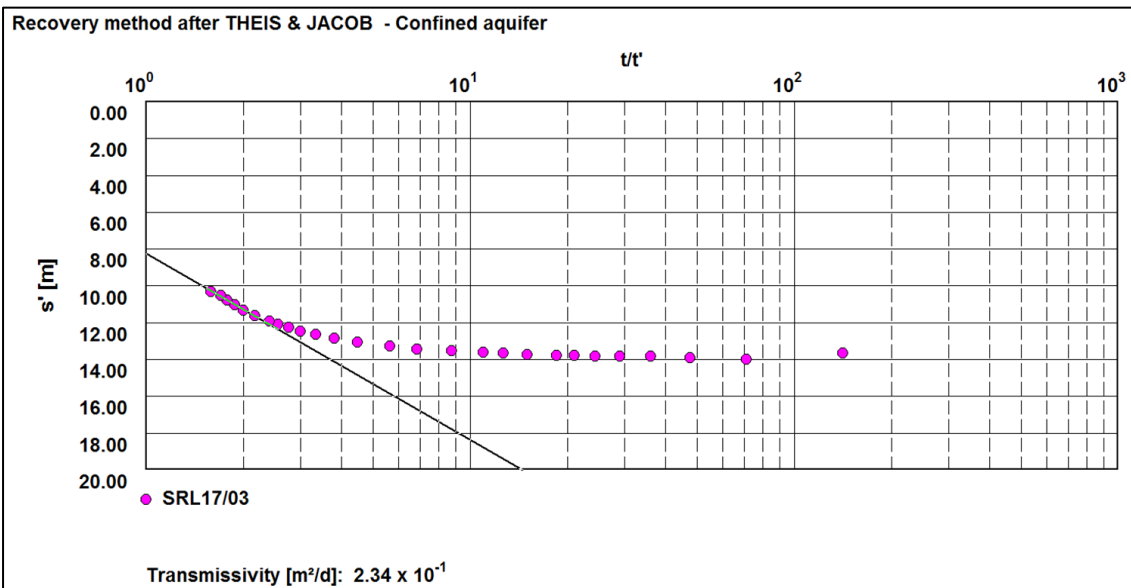
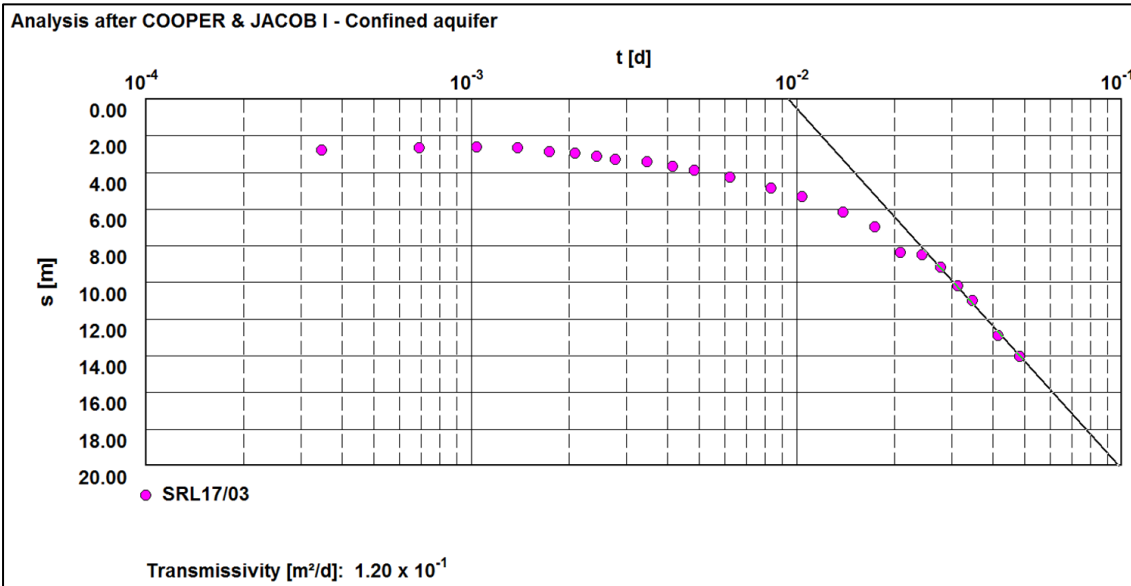
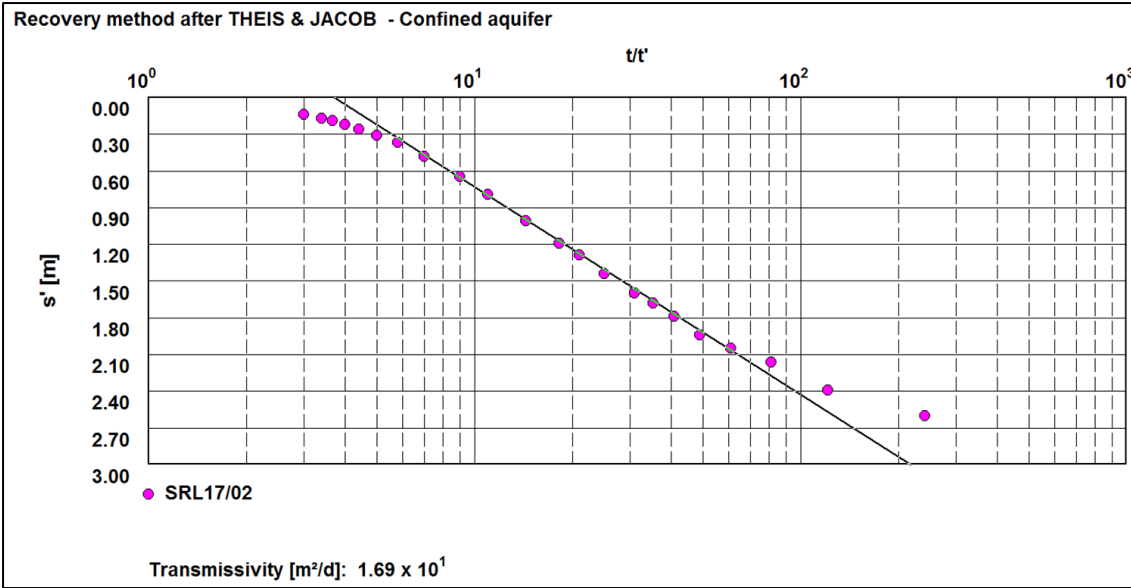
INCLINATION :  
DIAM :  
DATE : 19 August 2017  
DATE : 19 August 2017  
DATE : 16/02/2018 10:31  
TEXT : ..L\FINALSIERRALOGSALL.DOC

ELEVATION : 49m  
X-COORD : 802975  
Y-COORD : 862423

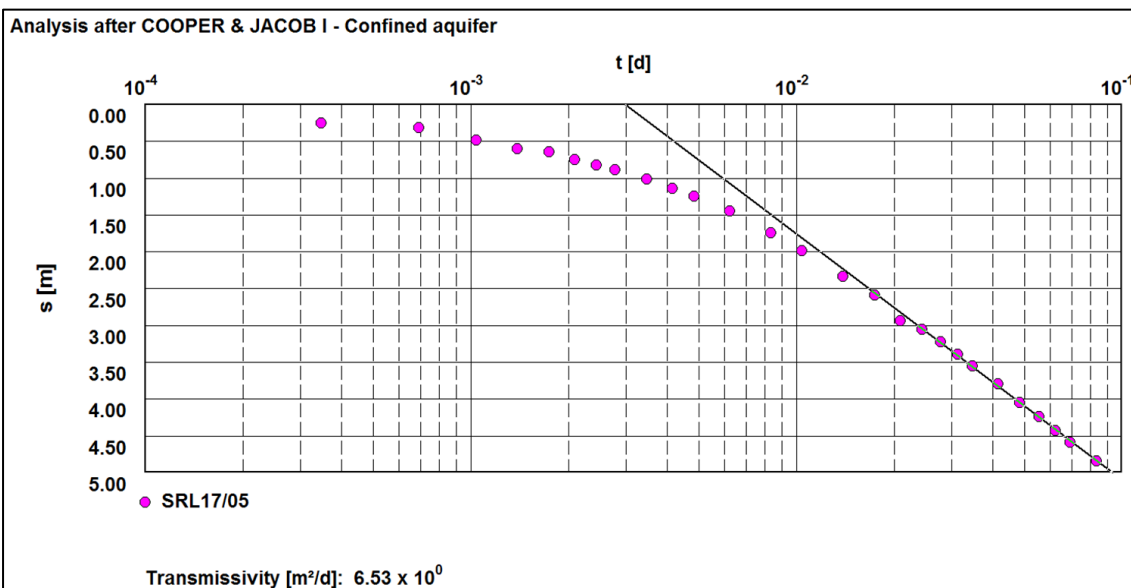
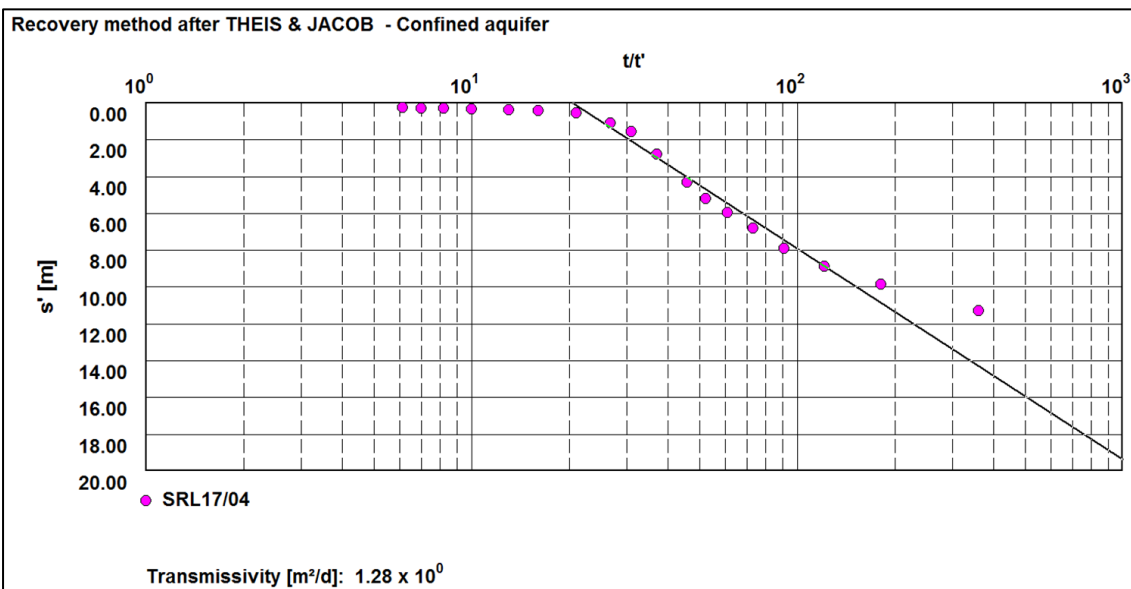
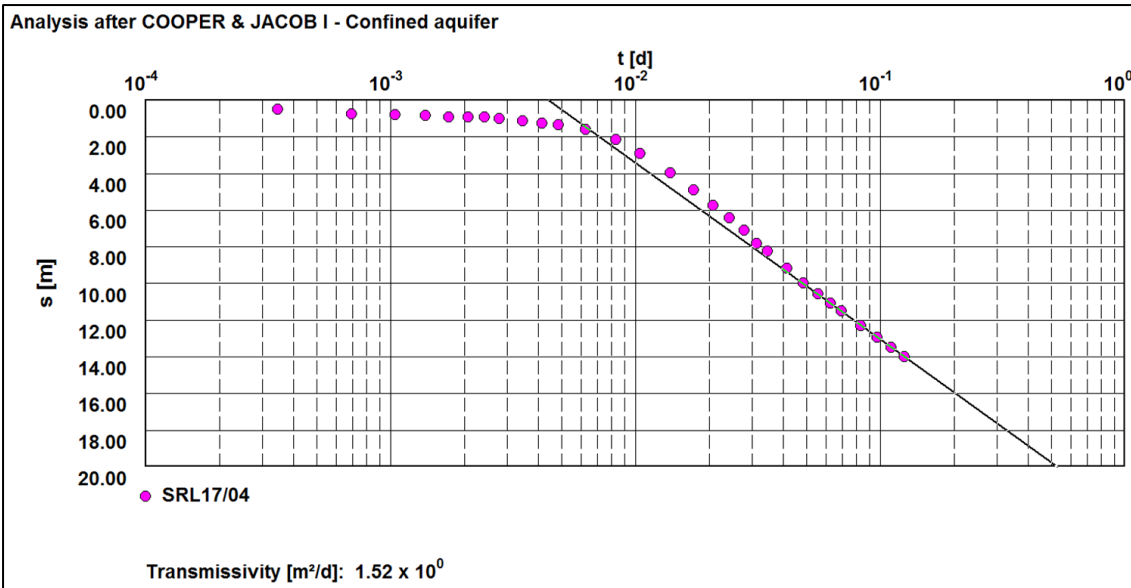
HOLE No: **SRL17-16**

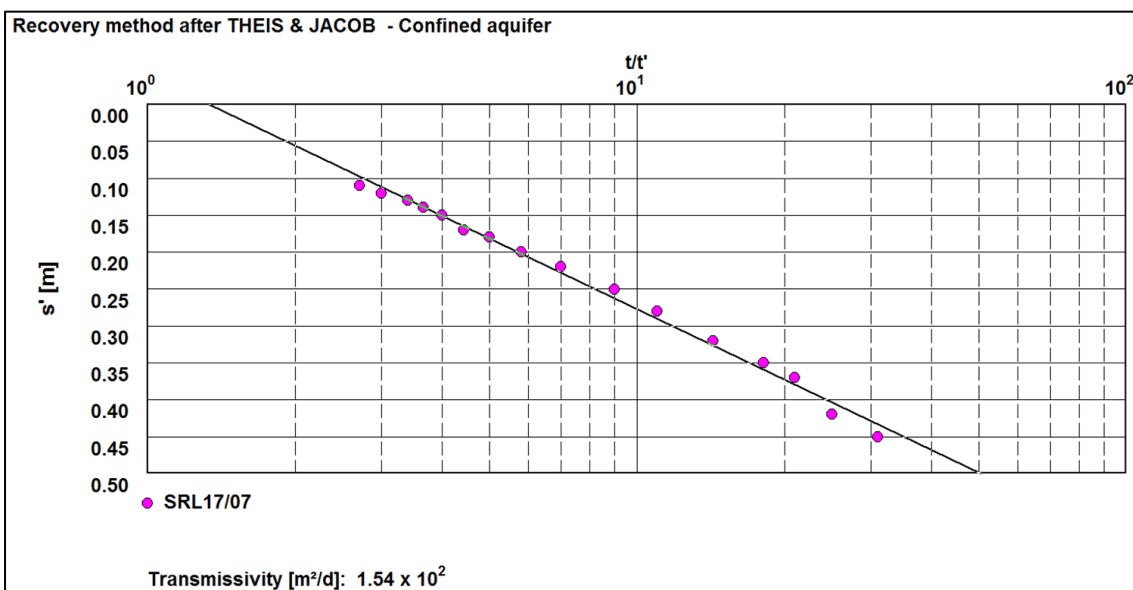
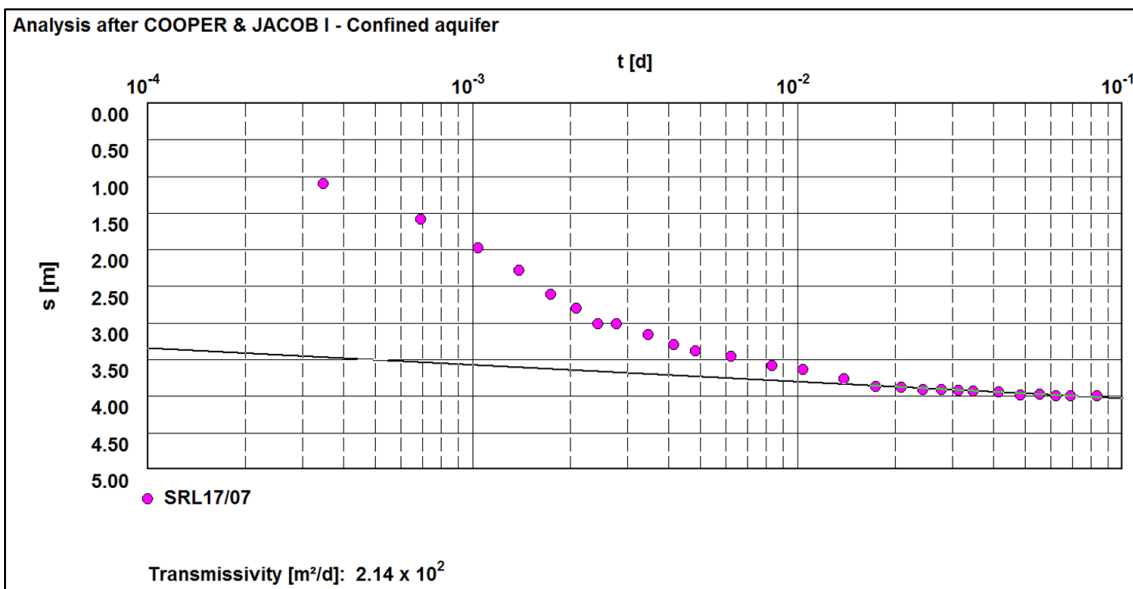
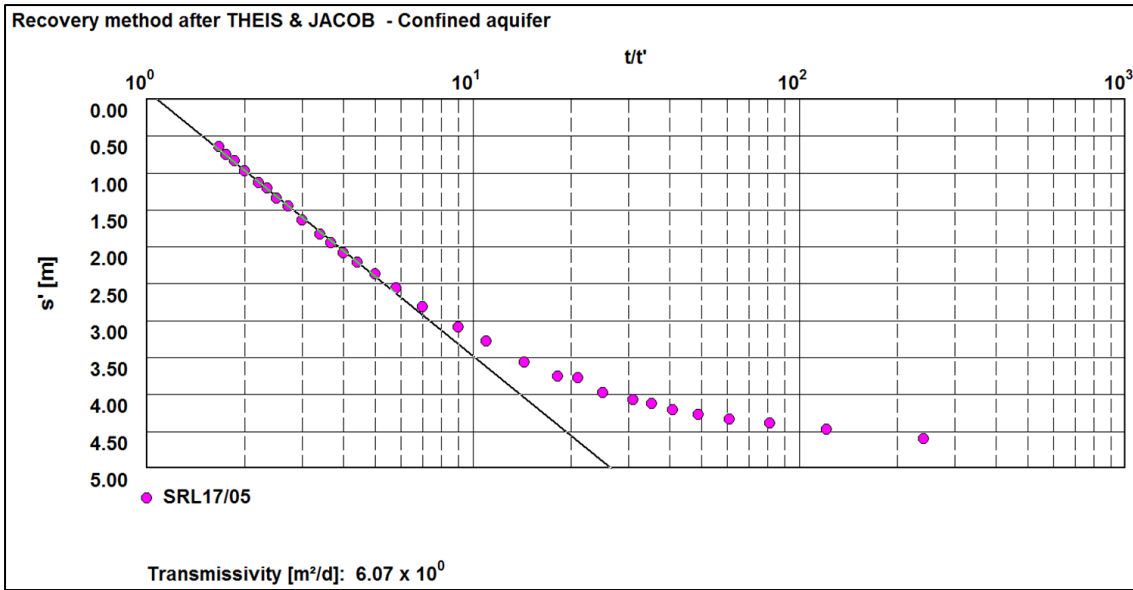
## **APPENDIX B: PUMP TESTING ANALYSES**

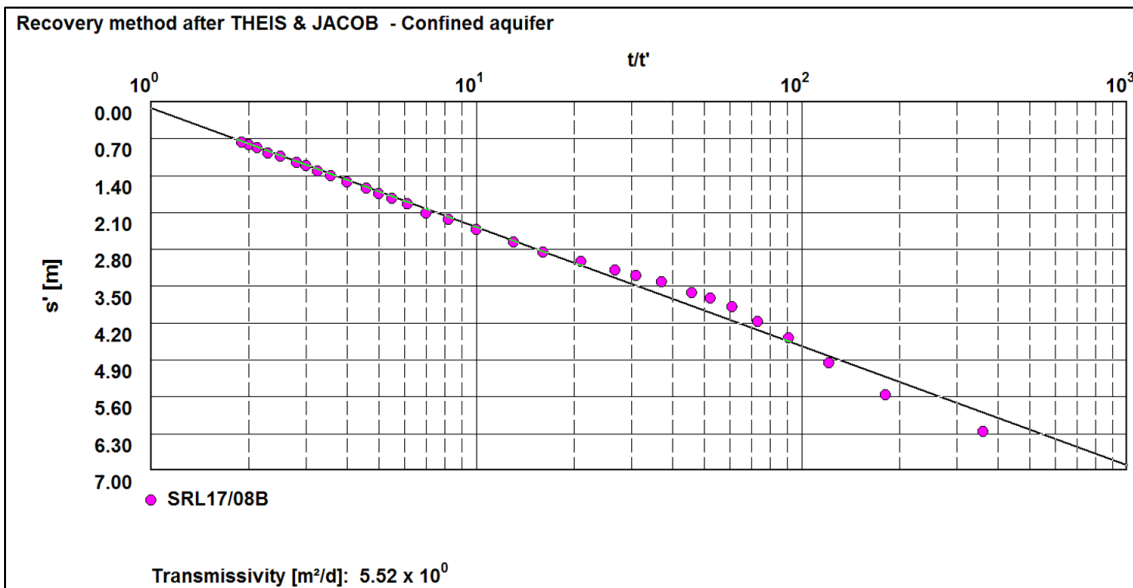
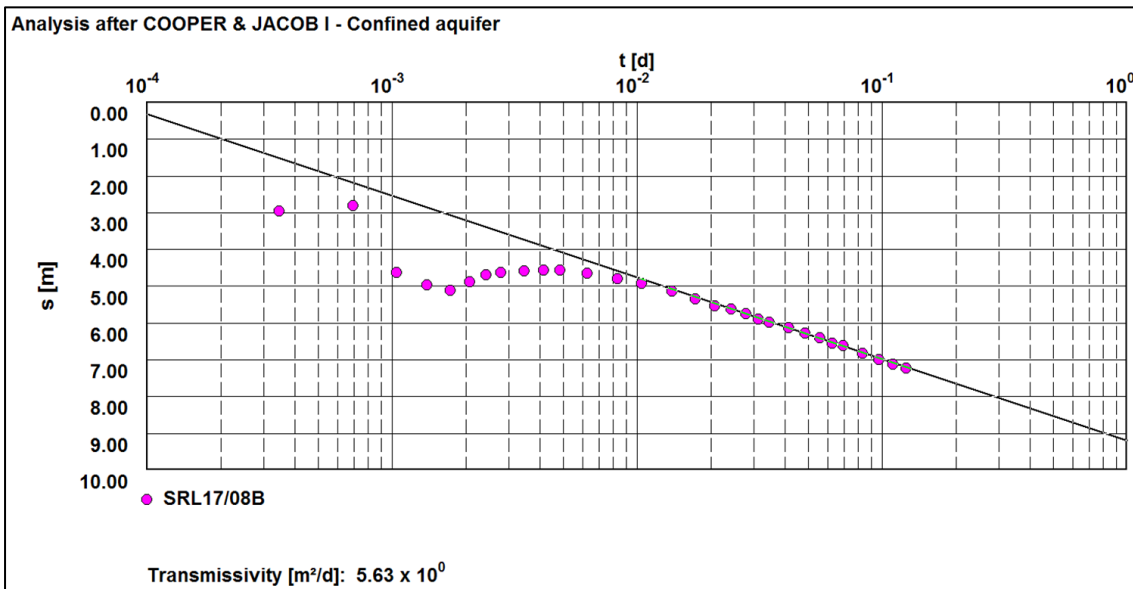
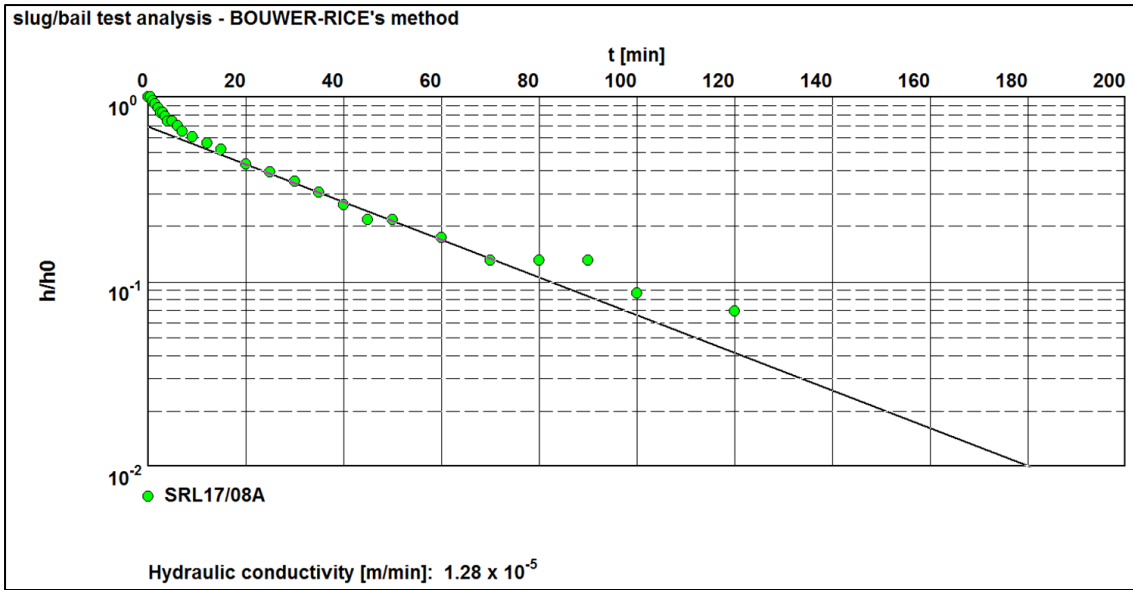


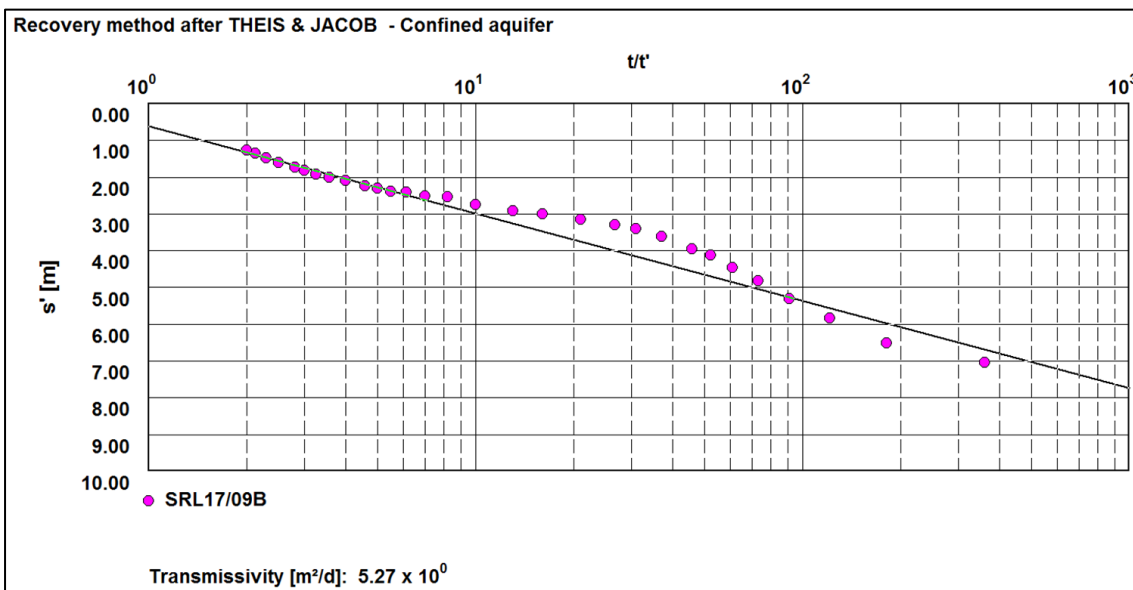
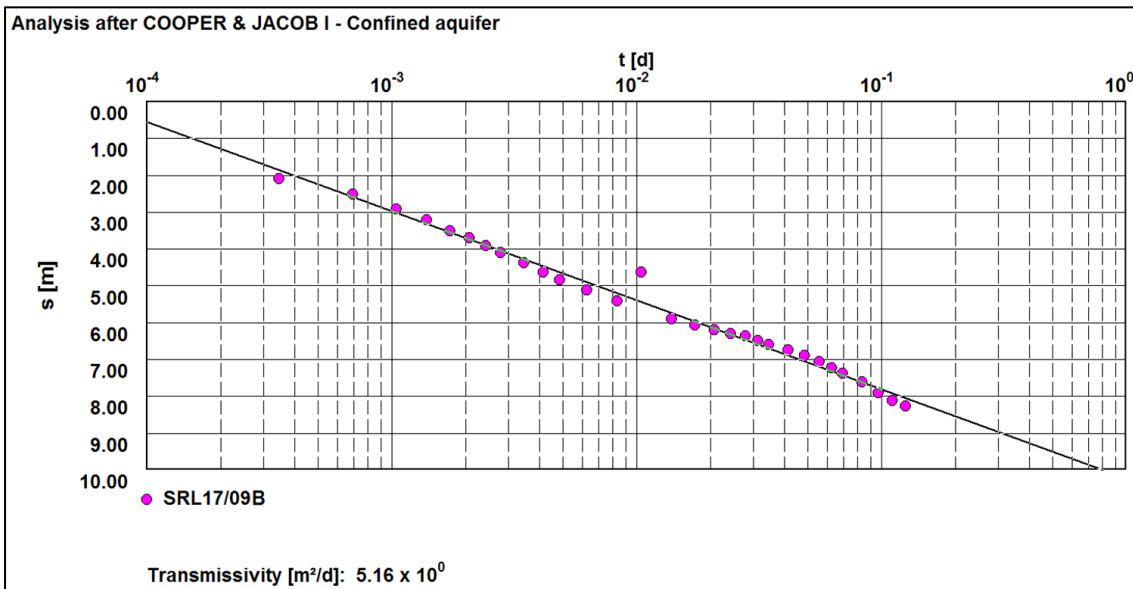
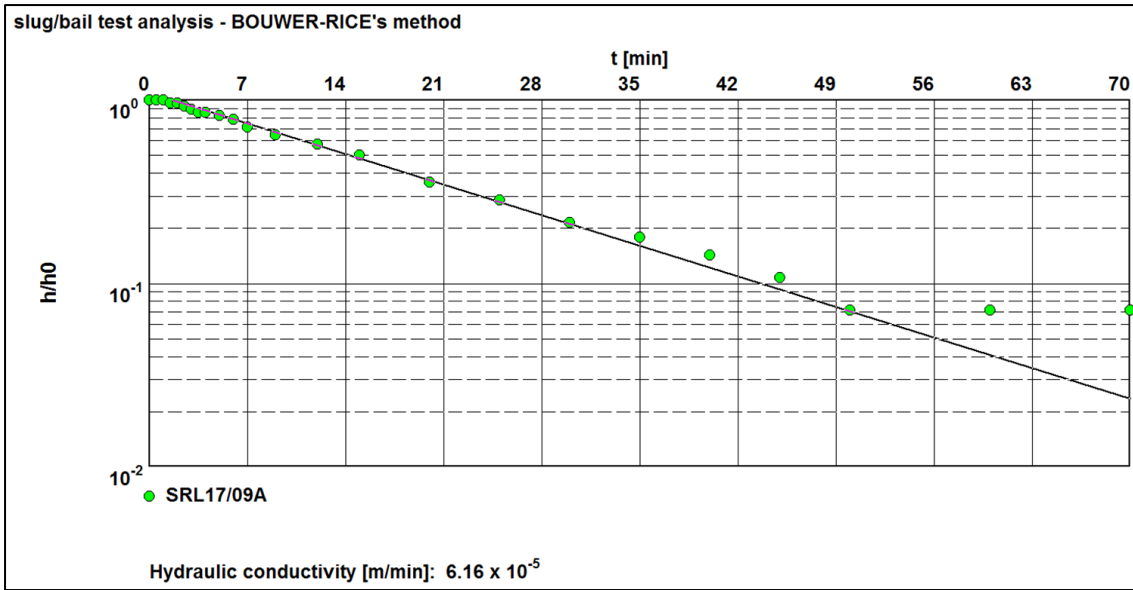


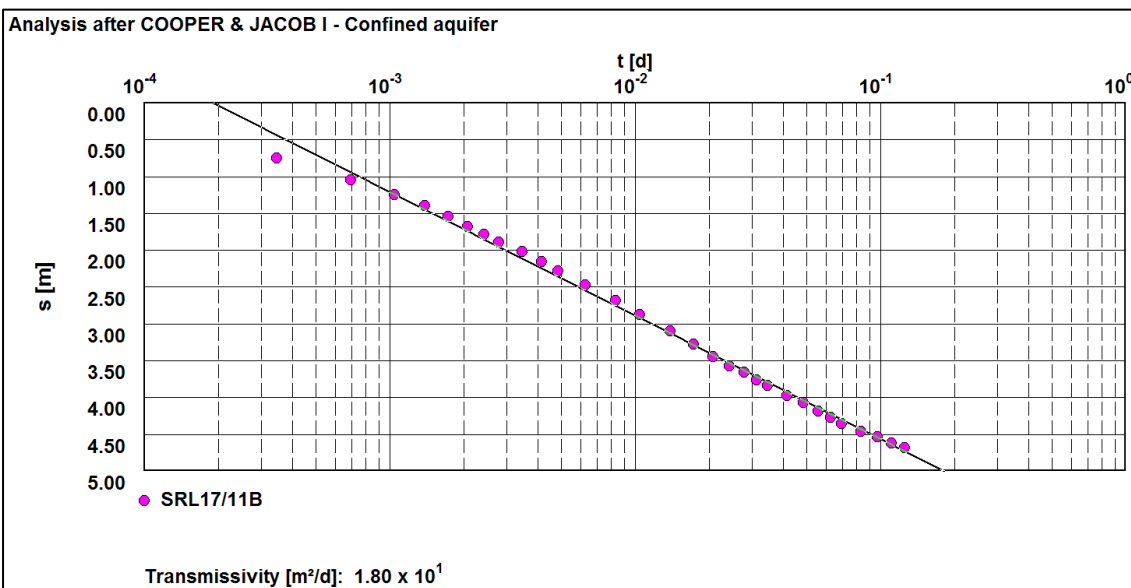
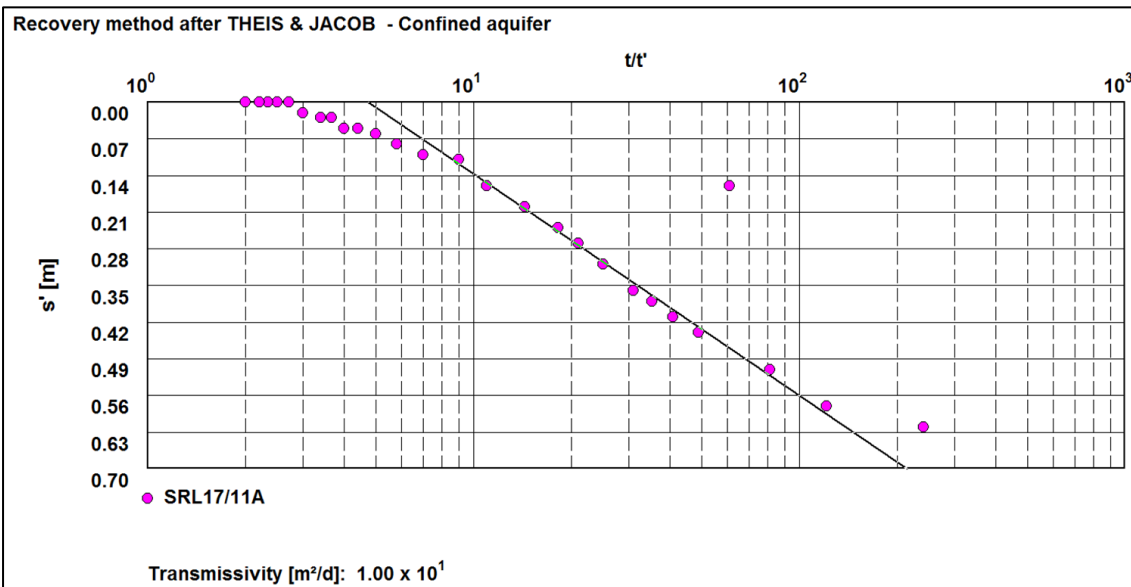
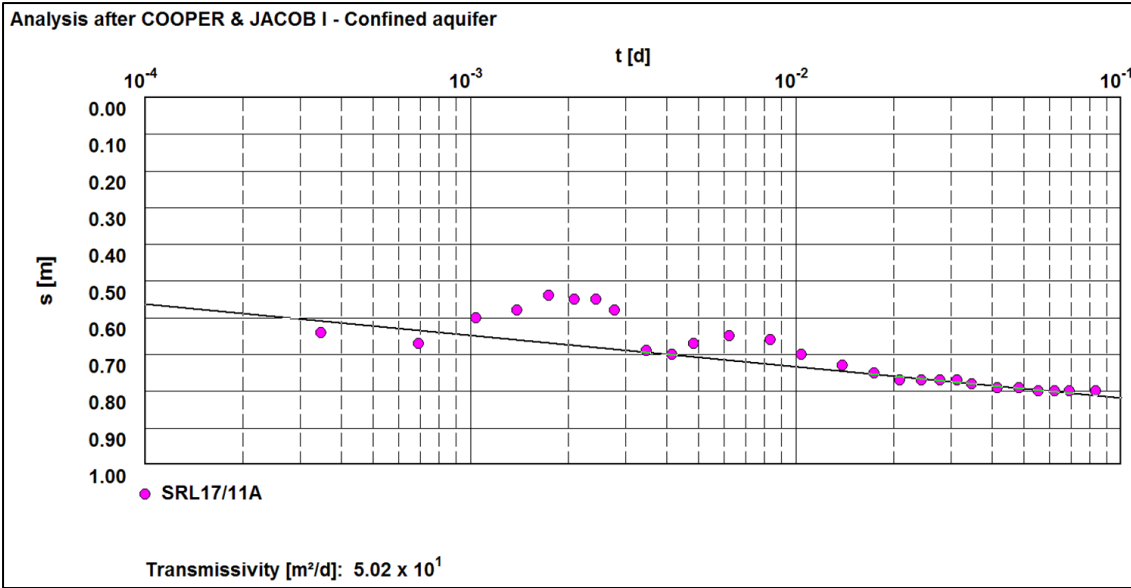


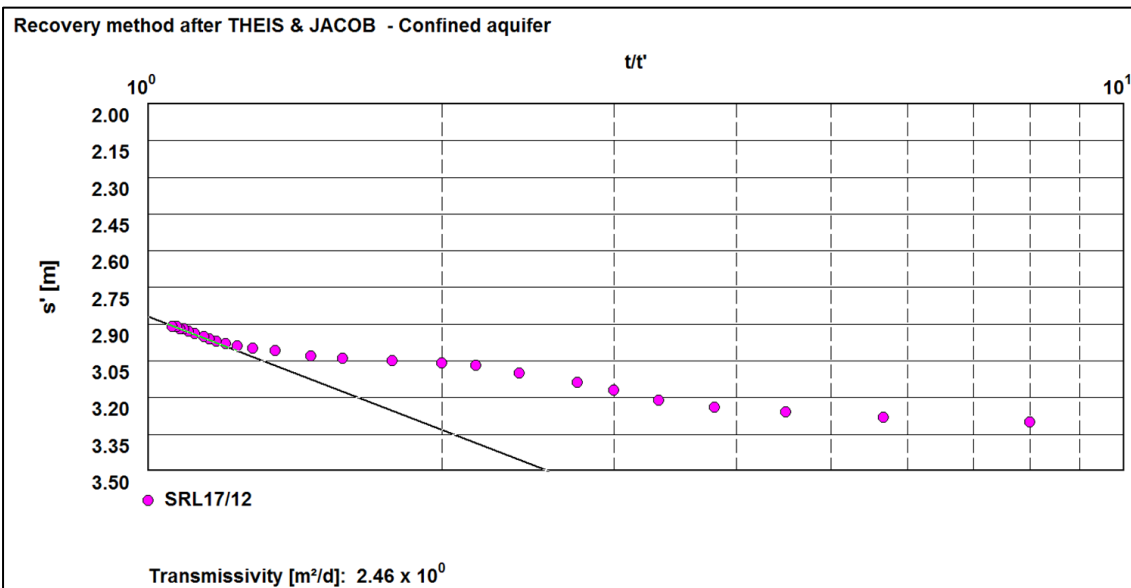
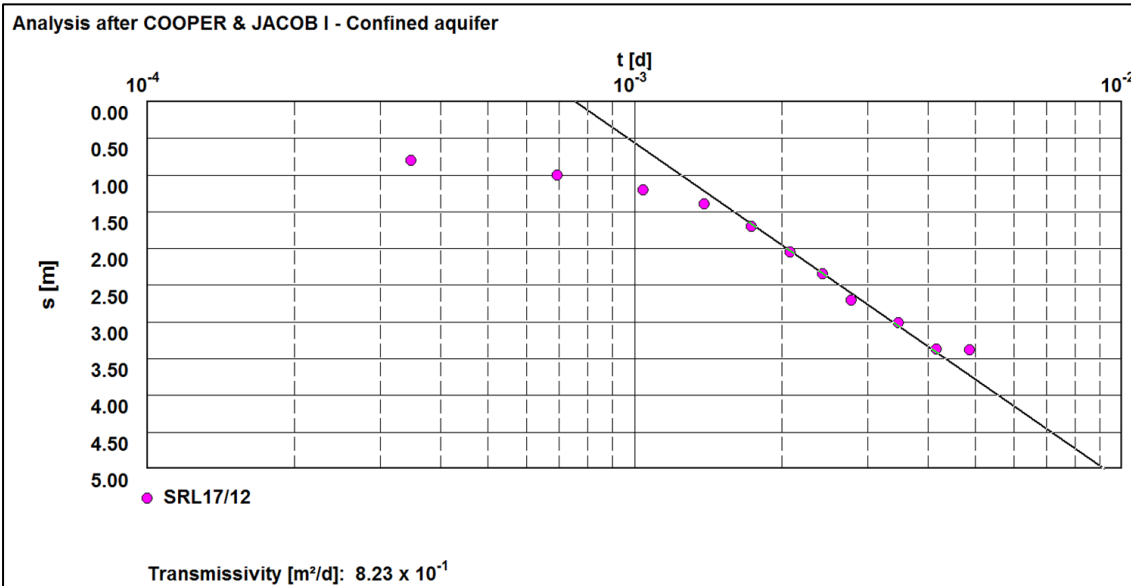
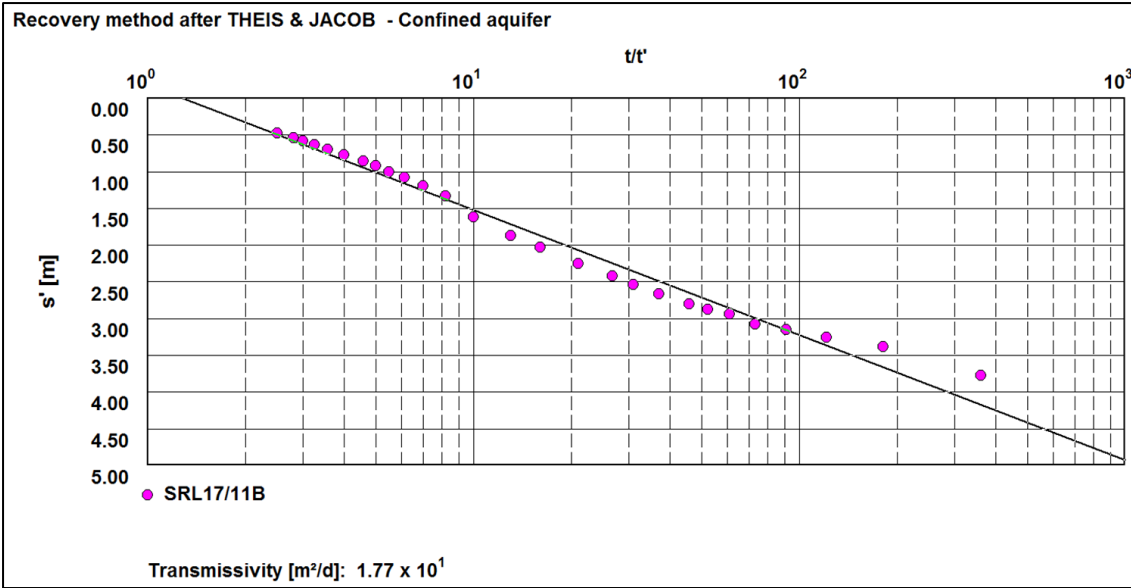


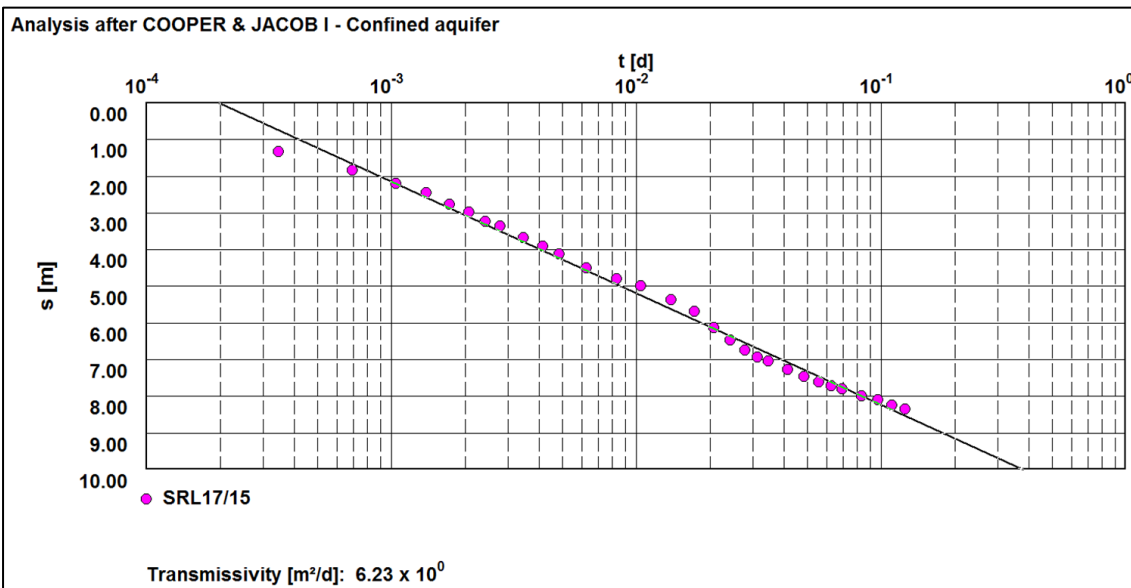
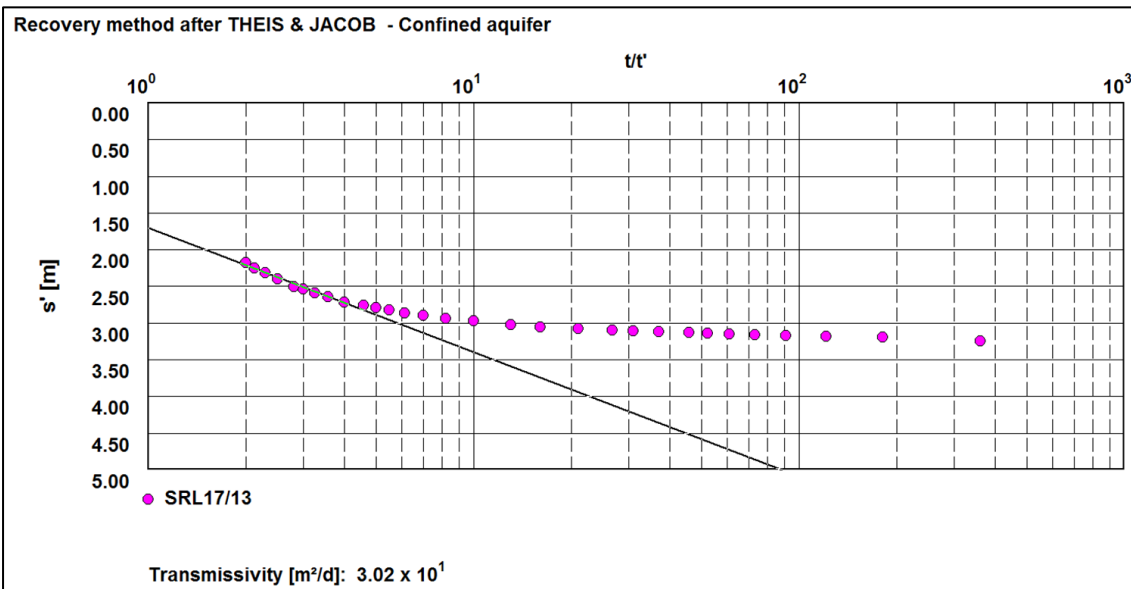
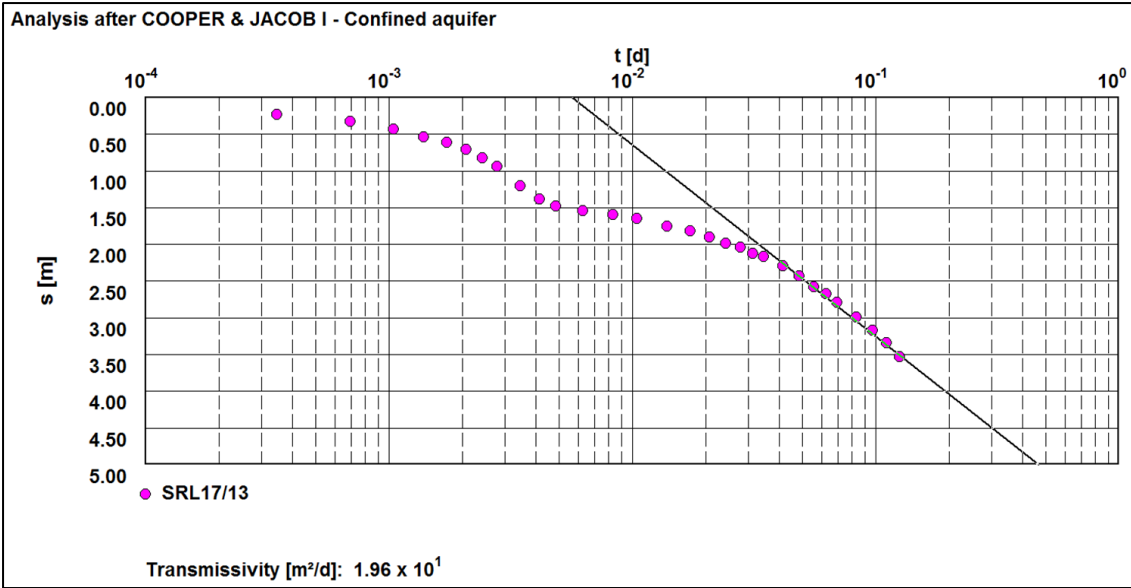


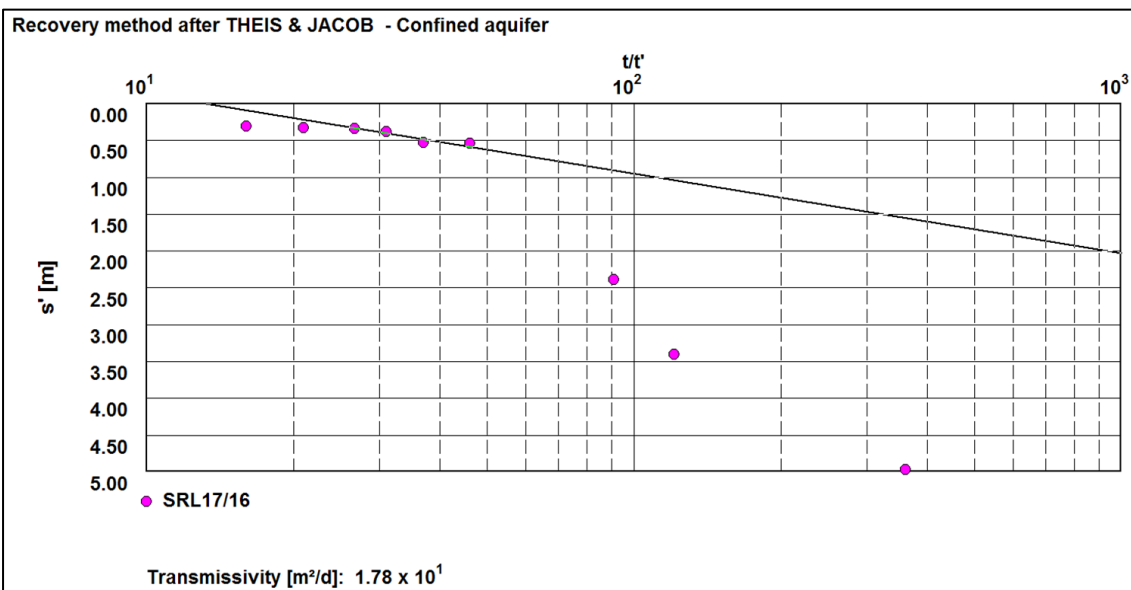
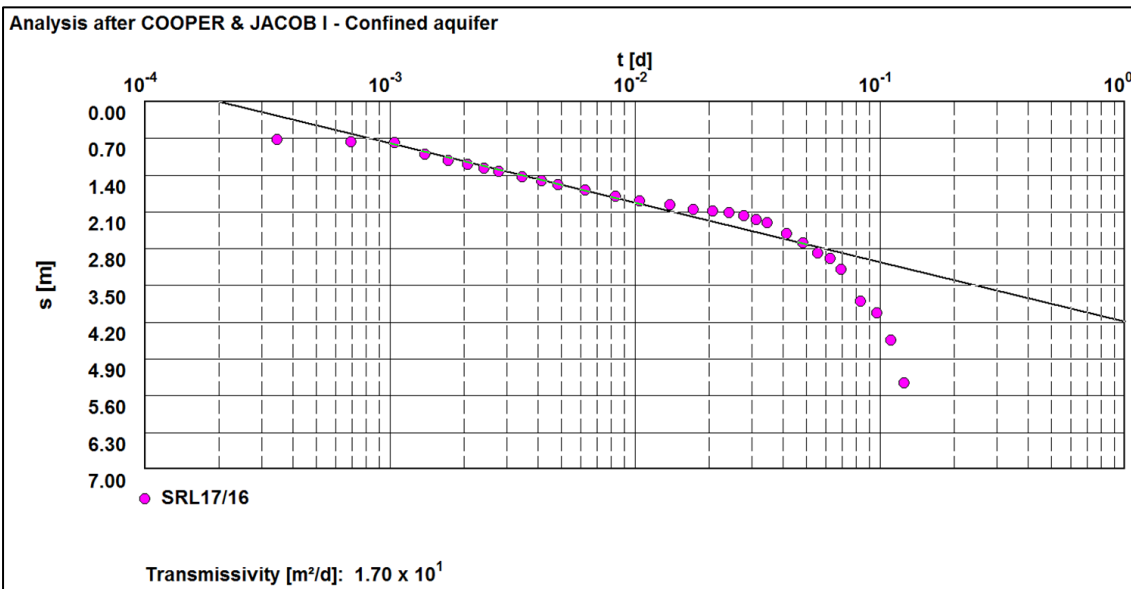
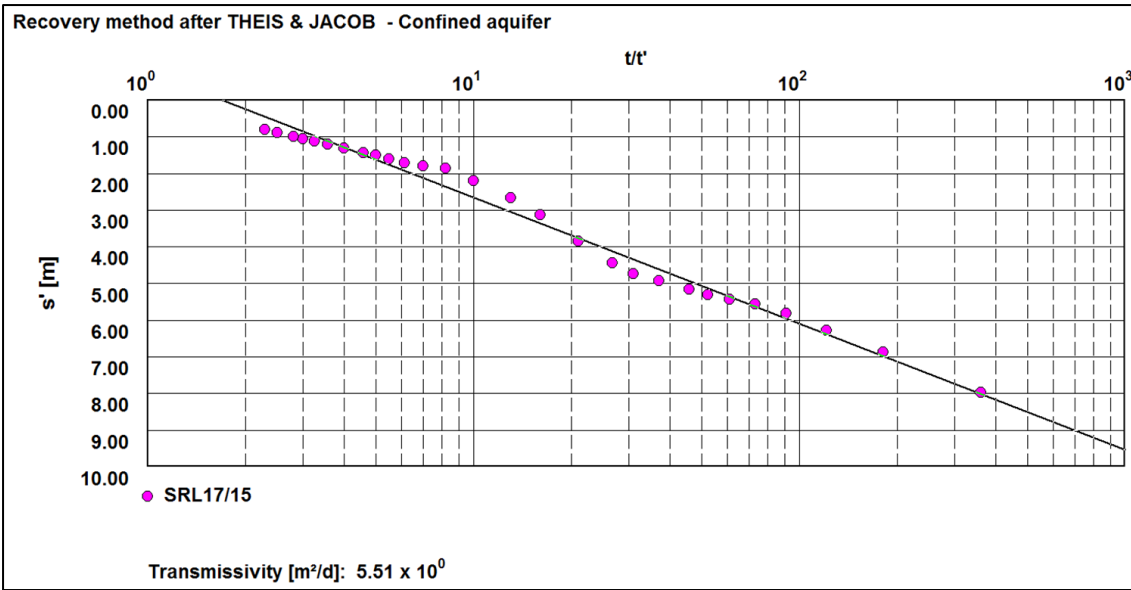














## **APPENDIX C: HISTORICAL WATER ANALYSES AND EFFLUENT STANDARDS**

**Sierra Rutile Limited  
Sierra Rutile Project  
Water Monitoring Report**

**Table 3  
Knight Piésold Laboratory Analysis of Surface and Groundwater Quality Parameters, March 2001**

<b>Analyte</b>	<b>WHO Water Quality Guidelines</b>	<b>Units</b>	<b>CT-WS-01 56961-1 3/3/01 Water</b>	<b>P-WS-02 56961-2 3/3/01 Water (f)</b>	<b>M-WS-03 56961-3 3/3/01 Water</b>	<b>K-WS-04 56961-4 3/3/01 Water</b>	<b>T-WS-05 56961-5 3/3/01 Water</b>	<b>MT-WS-06 56961-6 3/3/01 Water (f)</b>	<b>LR-WS-07 56961-7 3/3/01 Water</b>
pH		pH Units	4.0	4.7	4.3	5.6	5.6	5.4	6.2
Electrical Conductivity @ 25oC		µS/cm	76	72	35	12	13	25	10000
Total Dissolved Solids (grav) @ 180oC	1000d	mg/L	50a	45a	25a	<10a	<10a	15a	<b>6000</b>
Iron, Fe (Soluble)	0.3d	mg/L	<0.05	<0.05	<0.05	0.15	<0.05	<0.05	<0.05
Sodium, Na	200d	mg/L	1.5	4	1.1	1.4	1.1	1.9	<b>1800</b>
Potassium, K		mg/L	<0.5	2.8	<0.5	<0.5	<0.5	<0.5	62
Calcium, Ca		mg/L	1.1	2.6	1.0	0.8	0.8	1.5	69
Magnesium, Mg		mg/L	<0.5	0.8	<0.5	<0.5	<0.5	<0.5	310
Total Alkalinity as CaCO3		mg/L	<5	<5	<5	5	<5	5	20
Chloride, Cl	250d	mg/L	<5	<5	<5	<5	<5	<5	<b>3100</b>
Sulphate, SO4	250d	mg/L	<10	<10	<10	<10	<10	<10	<b>440</b>
Nitrate-Nitrogen, NO3-N	50b	mg/L	<0.05	0.40	<0.05	<0.05	<0.05	0.13	<0.05
Nitrite-Nitrogen, NO2-N	3b; 0.2ce	mg/L	<0.01	0.01	<0.01	<0.01	<0.01	<0.01	<0.01
Flouride, F	1.5	mg/L	<0.1	<0.1	<0.1	<0.1	<0.1	<0.1	0.2
Aluminum, Al	0.2d	mg/L	<b>0.4</b>	<b>0.3</b>	0.1	0.1	0.1	<b>0.2</b>	0.1
Silver, Ag		mg/L	<0.01	<0.01	<0.01	<0.01	<0.01	<0.01	<0.01
Arsenic, As	0.01c	mg/L	0.001	<0.001	<0.001	<0.001	<0.001	<0.001	<0.001
Barium, Ba	0.7	mg/L	<0.01	0.02	<0.01	<0.01	<0.01	<0.01	<0.01
Beryllium, Be		mg/L	<0.00010	0.00020	<0.00010	<0.00010	<0.00010	<0.00010	<0.00010
Cadmium, Cd	0.003	mg/L	<0.001	<0.001	<0.001	<0.001	<0.001	<0.001	<b>0.004</b>
Chromium, Cr	.05c	mg/L	<0.005	<0.005	<0.005	<0.005	<0.005	<0.005	0.005

**Sierra Rutile Limited  
Sierra Rutile Project  
Water Monitoring Report**

**Table 3  
Knight Piésold Laboratory Analysis of Surface and Groundwater Quality Parameters, March 2001**

<b>Analyte</b>	<b>WHO Water Quality Guidelines</b>	<b>Units</b>	<b>CT-WS- 01 56961-1 3/3/01 Water</b>	<b>P-WS-02 56961-2 3/3/01 Water (f)</b>	<b>M-WS-03 56961-3 3/3/01 Water</b>	<b>K-WS- 04 56961-4 3/3/01 Water</b>	<b>T-WS- 05 56961-5 3/3/01 Water</b>	<b>MT-WS- 06 56961-6 3/3/01 Water (f)</b>	<b>LR-WS- 07 56961-7 3/3/01 Water</b>
Copper, Cu	2c	mg/L	<0.05	<0.05	<0.05	<0.05	<0.05	<0.05	<0.05
Mercury, Hg	0.001	mg/L	<0.00010	<0.00010	<0.00010	<0.00010	<0.00010	<0.00010	<0.00010
Manganese, Mn	0.5c	mg/L	0.15	<0.05	0.20	<0.05	<0.05	<0.05	<0.05
Nickel, Ni	0.02c	mg/L	<0.005	<0.005	<0.005	<0.005	<0.005	<0.005	<0.005
Lead, Pb	0.01	mg/L	<0.005	<0.005	<0.005	<0.005	<0.005	<0.005	<0.005
Selenium, Se	0.01	mg/L	<0.01	<0.01	<0.01	<0.01	<0.01	<0.01	<0.01
Thallium, Tl		mg/L	<0.00050	<0.00050	<0.00050	<0.00050	<0.00050	<0.00050	<0.00050
Zinc, Zn	3d	mg/L	<0.05	0.35	<0.05	<0.05	<0.05	<0.05	<0.05
TRH C6-C9		µg/L		<40				<40	
TRH C10-C14		µg/L		<40				<40	
TRH C15-C28		µg/L		<200				<200	
TRH C29-C36		µg/L		<200				<200	
TRH Surrogates (o-terphenyl)		% Recovery		96				75	
Arochlor 1016		µg/L		<1.0				<1.0	
Arochlor 1221		µg/L		<1.0				<1.0	
Arochlor 1232		µg/L		<1.0				<1.0	
Arochlor 1242		µg/L		<1.0				<1.0	
Arochlor 1248		µg/L		<1.0				<1.0	
Arochlor 1254		µg/L		<1.0				<1.0	
Arochlor 1260		µg/L		<1.0				<1.0	

**Sierra Rutile Limited  
Sierra Rutile Project  
Water Monitoring Report**

**Table 3  
Knight Piésold Laboratory Analysis of Surface and Groundwater Quality Parameters, March 2001**

<b>Analyte</b>	<b>WHO Water Quality Guidelines</b>	<b>Units</b>	<b>CT-WS- 01 56961-1 3/3/01 Water</b>	<b>P-WS-02 56961-2 3/3/01 Water (f)</b>	<b>M-WS-03 56961-3 3/3/01 Water</b>	<b>K-WS- 04 56961-4 3/3/01 Water</b>	<b>T-WS- 05 56961-5 3/3/01 Water</b>	<b>MT-WS- 06 56961-6 3/3/01 Water (f)</b>	<b>LR-WS- 07 56961-7 3/3/01 Water</b>
Total Organic Carbon		mg/L	<1	<1	<1	<1	1.4	<1	2.2
Alpha	100000	mBq/L	<5	42 ± 6	10 ± 2	21 ± 4	<5	5 ± 1	<5
Beta	10000000	mBq/L	<10	394 ± 39	55 ± 7	89 ± 11	40 ± 5	25 ± 3	<10

a Calculated TDS

b Acute guideline level

c Provisional guideline value. This term is used for constituents for which there is some evidence of a potential hazard but where the available information on health effects is limited; or where an uncertainty factor greater than 1000 has been used in the derivation of the tolerable daily intake (TDI). Provisional guideline values are also recommended: (1) for substances for which the calculated guideline value would be below the practical quantification level, or below the level that can be achieved through practical treatment methods; or (2) where disinfection is likely to result in the guideline value being exceeded.

d Substances and parameters in drinking-water that may give rise to complaints from consumers

e Chronic guideline level

f. Groundwater samples

Note: Parameters exceeding WHO Guidelines are bolded.

**Table 5-1: Quality data of samples taken during SRK Water Site Visit.**

SampleID	Unit	MONDORKOH	MOGBWEMO	PEJEBU	RAIN WATER
Water type	-	Well	Well	Old Dam	Rain
pH_lab	-	6.8	6	6.6	7.2
EC	mS/m	8.7	5.2	1.6	5.1
TDS	mg/l	60	40	8	54
Ca	mg/l	14	3.2	0.71	4.5
Mg	mg/l	0.52	0.51	0.25	0.17
Na	mg/l	5	3	1.3	1.5
K	mg/l	2.2	0.85	1.5	0.093
Cl	mg/l	3.3	1.9	1.7	1.8
Meas_Alkal	mg/l	17	2	2.2	7.7
HCO <sub>3</sub>	mg/l	21	2.4	2.7	9.4
CO <sub>3</sub>	mg/l	0	0	0	0
SO <sub>4</sub>	mg/l	2.2	0.3	0.4	1.6
F	mg/l	0.1	0.1	0.1	1
NO <sub>3</sub>	mg/l	12.6	9.3	0.1	1.9
As_tot	mg/l	0.002	0.004	0.007	0.006
B	mg/l	0.006	0.006	0.006	0.006
Ba	mg/l	0.01	0.009	0.005	0.003
Cd_tot	mg/l	0.001	0.001	0.001	0.001
Fe_tot	mg/l	0.001	0.02	0.3	0.01
Hg_tot	mg/l	0.001	0.001	0.001	0.001
Meas_Hardness	mg/l	2.1	2.1	1	1
Mn_tot	mg/l	0.007	0.007	0.03	0.01
Mo_tot	mg/l	0.001	0.001	0.001	0.001
Ni_tot	mg/l	0.003	0.003	0.003	0.003
Pb_total	mg/l	0.001	0.001	0.001	0.004
Sb_tot	mg/l	0.01	0.01	0.01	0.01
Se_diss	mg/l	0.008	0.001	0.001	0.002
Si	mg/l	2.4	1.8	1.8	0.13
Sr	mg/l	0.04	0.01	0.004	0.01
Tl_tot	mg/l	0.009	0.009	0.009	0.009
U_tot	mg/l	0.004	0.004	0.004	0.004
V_tot	mg/l	0.002	0.002	0.002	0.002
Zn_tot	mg/l	0.007	0.03	0.009	3.6

**Republic of Sierra Leone: Environment Protection (Mines and Minerals) Regulations, 2013.**

**Effluent Standards**

<b>Parameter</b>	<b>Units</b>	<b>Limit at any Moment</b>	<b>Annual Average Limit</b>
pH	s.u	6 - 9	6 - 9
TSS	mg/l	50	25
Oils and grease	mg/l	20	16
Total cyanide	mg/l	1.0	0.8
Total arsenic	mg/l	0.1	0.08
Total cadmium	mg/l	0.05	0.04
Hexavalent chrome*	mg/l	0.1	0.08
Total copper	mg/l	0.6	0.4
Iron (dissolved)	mg/l	2.0	1.6
Total lead	mg/l	0.2	0.16
Total mercury	mg/l	0.002	0.0016
Total zinc	mg/l	1.5	1.2

\* Unfiltered sample

## **APPENDIX B: PUMP TESTING ANALYSES**

## **APPENDIX C: HISTORICAL WATER ANALYSES AND EFFLUENT STANDARDS**